

Fluid Level and
Temperature Indicators

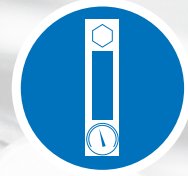

Tank Filler Breathers



Particle and Desiccant Breathers



Suction Strainers



Diffusors



**Plastic Filler Breather - Types SPB 1 / 2 / 3
(Screw-In Version)**

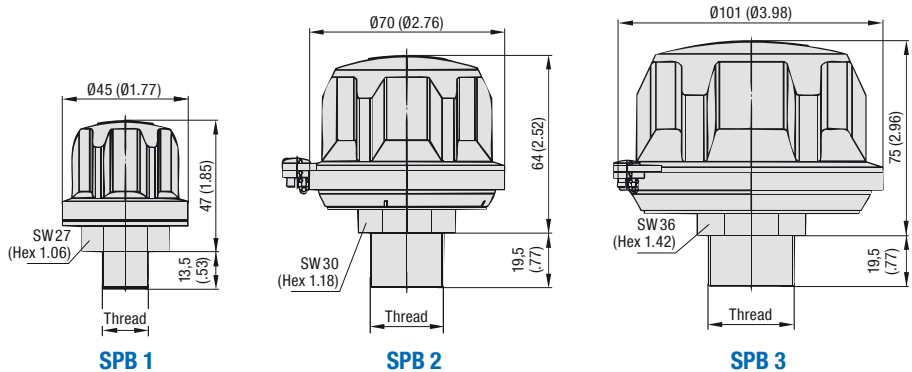

SPB 1

SPB 2

SPB 3

(See page E16 for compact version SPBN)

Characteristics

Designed to be used as filler ports for hydraulic reservoirs, allowing the reservoir to breathe whilst protecting it from contamination found in harsh environments

Features

- Available with 3 different cap diameters
- Screw-in version, equipped with male BSP thread (ISO 228) or male NPT thread (ANSI B1.20.1)
- Operating temperature range: -40 °C ... +120 °C / -40 °F ... +248 °F

Materials

- Made of non-corrosive materials
- Body and cap made of glass-fibre reinforced Polyamide (PA)
- Sealings made of NBR (Buna-N®)

Consult STAUFF for alternative materials.

Accessories / Options

- Pressurisation up to 0,7 bar / 10PSI (not available for SPB 1)
- Air filter element
- Anti-splash feature
- Plastic dipstick with integrated anti-splash feature

Please see page E14 for details.

Maximum Air Flow Rate

- 0,15 m³/min / 5.30 cfm for SPB 1
- 0,40 m³/min / 14.13 cfm for SPB 2
- 1,00 m³/min / 35.31 cfm for SPB 3

Please see page E15 for detailed air flow curves.

Oil Displacement

- 150 l/min / 40 USGPM for SPB 1
- 400 l/min / 106 USGPM for SPB 2
- 1000 l/min / 264 USGPM for SPB 3

Installation

- Recommended mounting spaces:
 - Ø48 mm / Ø1.89 in for SPB 1,
 - Ø90 mm / Ø3.54 in for SPB 2, and
 - Ø122 mm / Ø4.80 in for SPB 3

Thread Options

Thread	SPB 1	SPB 2	SPB 3	Code
Male BSP Thread (ISO 228)				
G1/4	●	○	○	B04
G3/8	●	●	○	B06
G1/2	●	●	●	B08
G3/4	○	●	●	B12
G1	○	○	●	B16

Thread	SPB 1	SPB 2	SPB 3	Code
Male NPT Thread (ANSI B1.20.1)				
1/4	●	○	○	N04
3/8	●	○	○	N06
1/2	●	○	○	N08
3/4	●	●	●	N12
1	○	○	●	N16

● Standard Option

Order Codes

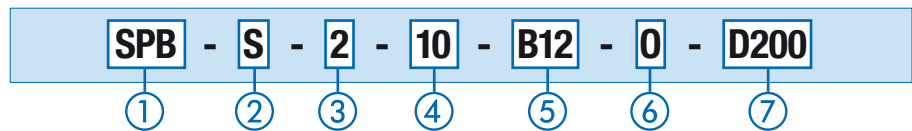

① Type

Plastic Filler Breather **SPB**

② Pressurisation

Without pressurisation **S**
 Pressurised at 0,2bar / 3 PSI **P1**
 Pressurised at 0,35 bar / 5 PSI **P2**
 Pressurised at 0,7 bar / 10 PSI **P3**

Type SPB 1 is only available without pressurisation. Please see page E14 for details.

③ Version

Screw-in version; Cap diameter Ø45 mm (Ø1.77 in) **1**
 Screw-in version; Cap diameter Ø70 mm (Ø2.76 in) **2**
 Screw-in version; Cap diameter Ø101 mm (Ø3.98 in) **3**

④ Air Filter Element (Material / Micron Rating)

Without air filter element **00**
 10 µm Foam / PUR (standard option) **10**
 40 µm Foam / PUR **40**
 3 µm Inorganic Glass-Fibre, pleated **E03**
 10 µm Filter Paper, pleated **L10**

Options E03 and L10 are only available for type SPB 3. Consult STAUFF for alternative materials / micron ratings.

⑤ Connection Thread (Male)

G1/4 (for SPB 1 only) **B04**
 G3/8 (for SPB 1 and 2 only) **B06**
 G1/2 (for SPB 1, 2 and 3) **B08**
 G3/4 (for SPB 2 and 3 only) **B12**
 G1 (for SPB 3 only) **B16**
 1/4 NPT (for SPB 1 only) **N04**
 3/8 NPT (for SPB 1 only) **N06**
 1/2 NPT (for SPB 1 only) **N08**
 3/4 NPT (for SPB 1, 2 and 3) **N12**
 1 NPT (for SPB 3 only) **N16**

⑥ Anti-Splash Feature

With anti-splash feature (standard option) **A**
 Without anti-splash feature **0**

The anti-splash feature for the SPB 1, can only be achieved in conjunction with a dipstick, but is not available for the SPB 1 with connection sizes B04 and N04. Please see page E14 for details.

⑦ Dipstick

Plastic dipstick (200 mm / 7.88 in) with integrated anti-splash feature **D200**
 Plastic dipstick (300 mm / 11.81 in) with integrated anti-splash feature **D300**
 Without dipstick **-**

A shorter dipstick length can be achieved by simply cutting down the total length according to individual requirements. Please see page E14 for details.

Plastic Filler Breather ▪ Types SPB 4 / 5 (Flange Version)

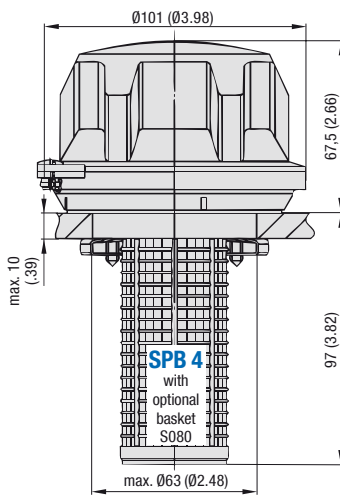

Clamping jaw installation
to a single mounting hole

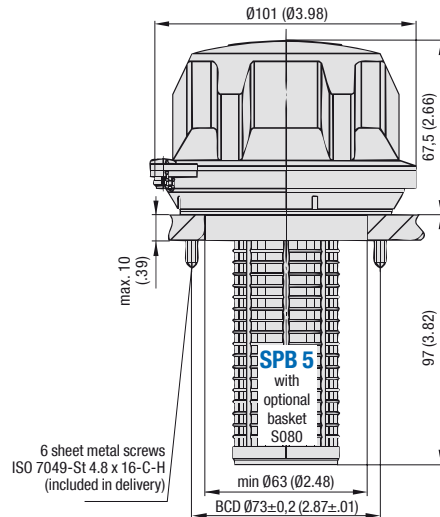

Installation to a six-hole bolt pattern
with flange interface similar to DIN 24557, Part 2



Characteristics

Designed to be used as filler ports for hydraulic reservoirs, allowing the reservoir to breathe whilst protecting it from contamination found in harsh environments

Features

- Cap diameter of Ø101 mm / Ø3.98 in
- Either for clamping installation (with 3 clamping jaws and cross-drive screws) or with a six-hole bolt pattern
- Operating temperature range:
-40 °C ... +120 °C / -40 °F ... +248 °F

Materials

- Made of non-corrosive materials
- Body and cap made of glass-fibre reinforced Polyamide (PA)
- Sealings made of NBR (Buna-N®)

Consult STAUFF for alternative materials.

Accessories / Options

- Plastic basket (800 µm)
- Pressurisation up to 0,7 bar / 10 PSI
- Air filter element
- Anti-splash feature
- Plastic dipstick with integrated anti-splash feature

Please see page E14 for details.

Maximum Air Flow Rate

- 1,00 m³/min / 35.31 cfm for SPB 4+5

Please see page E15 for detailed air flow curves.

Oil Displacement

- 1000 l/min / 264 US GPM for SPB 4+5

Installation

- Recommended mounting space: Ø122 mm / Ø4.80 in
- Six-hole bolt pattern for flange interfaces similar to DIN 24557, part 2 (type SPB 5):

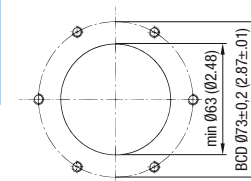

- 6 sheet metal screws (ISO 7049-St 4.8 x 16-C-H) are included in delivery (type SPB 5); can be replaced by regular M5 socket cap screws (ISO 4762), if required
- Recommended diameters of the screw holes, depending on the sheet thickness of the reservoir (type SPB 5):
Ø4,0 mm / Ø.16 in at a thickness of 1,20 mm / .05 in,
Ø4,1 mm / Ø.16 in at a thickness of 2,00 mm / .08 in,
Ø4,3 mm / Ø.17 in at a thickness of 4,00 mm / .16 in, and
Ø4,4 mm / Ø.17 in at a thickness of 5,00 mm / .20 in

Order Codes

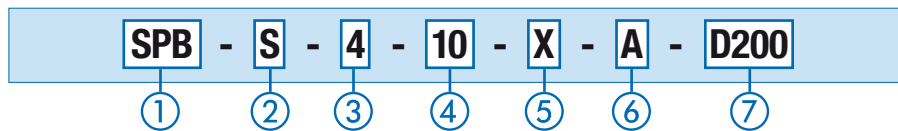

① Type

Plastic Filler Breather **SPB**

② Pressurisation

Without pressurisation **S**
 Pressurised at 0,2 bar / 3 PSI **P1**
 Pressurised at 0,35 bar / 5 PSI **P2**
 Pressurised at 0,7 bar / 10 PSI **P3**

Please see page E14 for details.

③ Version

Bayonet version for clamping jaw installation to a single mounting hole; Cap diameter Ø101 mm (Ø3.98 in) **4**
 Bayonet Version with six-hole bolt pattern for flange interfaces similar to DIN 24557, part 2; Cap diameter Ø101 mm (Ø3.98 in) **5**

④ Air Filter Element (Material / Micron Rating)

Without air filter element **00**
 10 µm Foam / PUR (standard option) **10**
 40 µm Foam / PUR **40**
 3 µm Inorganic Glass-Fibre, pleated **E03**
 10 µm Filter Paper, pleated **L10**

Consult STAUFF for alternative materials / micron ratings.

⑤ Basket Option

Plastic basket (105 mm / 4.13 in) **S080**
 Telescopic plastic basket **S200**
 (max. 205 mm / max. 8.07 in)
 Plastic basket with flange interface similar to DIN 24557, part 2 **S095P**
 (95 mm / 3.74 in)
 Without basket **X**

Option S095P is only available for type SPB 5.
 Please see page E14 for details.

⑥ Anti-Splash Feature

With anti-splash feature (standard option) **A**
 Without anti-splash feature **0**

⑦ Dipstick

Plastic dipstick (200 mm / 7.88 in) with integrated anti-splash feature **D200**
 Plastic dipstick (300 mm / 11.81 in) with integrated anti-splash feature **D300**
 Without dipstick **-**

A shorter dipstick length can be achieved by simply cutting down the total length according to individual requirements. When choosing a combination of a basket and a dipstick, the dipstick has to be at least 15 mm / .59 in shorter than the basket.
 Please see page E14 for details.

Plastic Dipstick - Types DS 1 / 2 / 3 Anti-Splash Feature

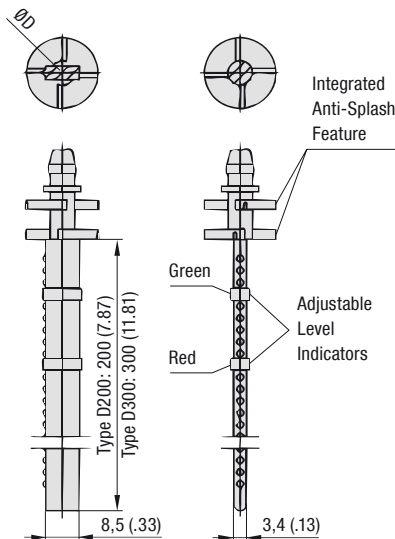
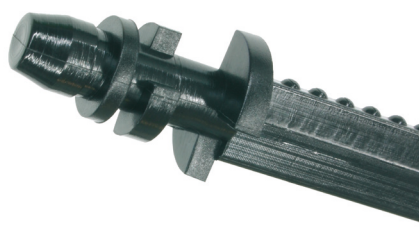

Connection	Code	For Type	Suitable Dipstick*	ØD (mm/in)
Male BSP Thread (ISO 228)	G1/4	B04	SPB 1	Dipstick Option Not Available
	G3/8	B06	SPB 1+2	DS-1
	G1/2	B08	SPB 1-3	DS-2
	G3/4	B12	SPB 1+2	DS-3
	G1	B16	SPB 3	DS-3
Male NPT Thread (ANSI B1.20.1)	1/4	N04	SPB 1	Dipstick Option Not Available
	3/8	N06	SPB 1	DS-1
	1/2	N08	SPB 1	DS-2
	3/4	N12	SPB 1-3	DS-3
	1	N16	SPB 3	DS-3
Plastic Basket	S080	SPB 4+5	DS-3	18 / .71
	S095-P	SPB 5	DS-3	18 / .71
	S200	SPB 4+5	DS-3	18 / .71
w/o Basket	X	SPB 4+5	DS-3	18 / .71

* When ordered separately, please add the length of the dipstick (in mm) to the ordering code (e.g. DS-2-300).

For all Plastic Filler Breathers (except type SPB 1 with connection sizes B04 and N04), dipsticks made of Polyamide are available as an option. These dipsticks are available in 2 standard lengths of 200 mm / 7.87 in and 300 mm / 11.81 in and equipped with 2 adjustable level indicators in green and red colour.

A shorter dipstick length can be achieved by simply cutting down the total length according to individual requirements.

All dipsticks have an integrated anti-splash feature protecting the SPB from backspilling fluid and avoiding an early breakdown of the air filter element.

For Plastic Filler Breathers without dipstick, the anti-splash function can be achieved by an integrated concave baffle. The anti-splash feature for the SPB 1 (except the type SPB 1 with connection sizes B04 and N04), can only be achieved in conjunction with a dipstick.

Please note: When choosing a combination of a dipstick and a basket (see below), the dipstick has to be at least 15 mm / .59 in shorter than the basket.

Special designs and alternative materials available on request. Please consult STAUFF for further details.

Plastic Basket - Types S080 / S095-P / S200

For the Plastic Filler Breathers SPB 4 and SPB 5, different types of baskets are available as an option. All baskets have a reinforced 0,8 x 3,5 mm / .03 x .14 in mesh (800 µm), so that rough dirt particles are filtered out of the medium and a smooth flow into the tank is being ensured.

The **Plastic Basket S080** (length of 105 mm / 4.13 in) snaps into the breather housing and suitable for the SPB 4 and SPB 5.

The **Plastic Basket S095-P** (length of 95 mm / 3.74 in) is equipped with a six-hole bolt pattern with flange interface similar to DIN 24557, part 2. It is suitable for the SPB 5 only and is installed between the breather housing of the SPB 5 and the reservoir.

The **Telescopic Plastic Basket S200** (maximum length of 205 mm / 8.07 in) is ideal to further improve the straining ability and oil flow-through and allowing longer dipstick lengths, where reservoir depth allows. It also snaps into the breather housing and is suitable for the SPB 4 and SPB 5.

Please note: When choosing a combination of a dipstick (see above) and a basket, the dipstick has to be at least 15 mm / .59 in shorter than the basket.

Special designs and alternative materials available on request. Please consult STAUFF for further details.

Plastic Basket S080 (for SPB 4+5)
Material: Polypropylene (PP)



Plastic Basket S095-P (only for SPB 5)
Material: Polyamide (PA)

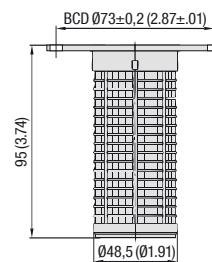

Six-hole bolt pattern with flange interface according to DIN 24557, part 2

Telescopic Plastic Basket S200 (for SPB 4+5)
Material: Polypropylene (PP)

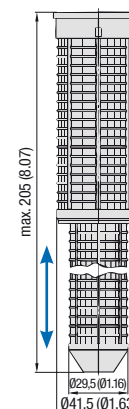

Pressurisation

All Plastic Filler Breathers (except the type SPB 1) are also available as pressurised versions with pressure settings of 0,7 bar / 10PSI, 0,35 bar / 5 PSI or 0,2 bar / 3 PSI. In order to achieve an air flow, the actual tank pressure has to exceed the chosen pressure setting of the Plastic Filler Breather.

When the fluid level inside the reservoir rises, no air is expelled from the reservoir until the pressurisation level is reached.

When the fluid level inside the reservoir falls, the tank pressure drops and air is drawn into the reservoir.

Due to less breathing, the service life of a filler breather and the oil can be increased by using the pressurisation feature. It also minimizes foaming and cavitation, and provides additional protection from moisture entering the reservoir which causes erosion and oil degradation.

Further Accessories / Options



Weld Riser - Type WR
Suitable for SPB 5
(See page E25 for details)

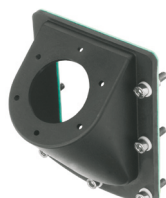

Side Mount Bracket (Polyamide) - Type ASMB-1
Suitable for SPB 5
(See page E24 for details)



Side Mount Bracket (Aluminium) - Type ASMB-2
Suitable for SPB 5
(See page E24 for details)

Dimensional drawings: All dimensions in mm (in).

Pressure Drop Flow Curves
 Plastic Filler Breathers

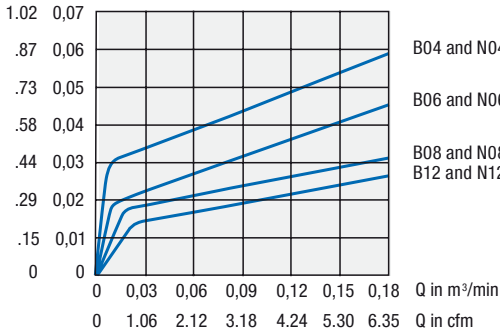
 Δp in PSI Δp in bar

Type SPB 1 (into / out of the tank)

B04 and N04 (into / out of the tank)

B06 and N06 (into / out of the tank)

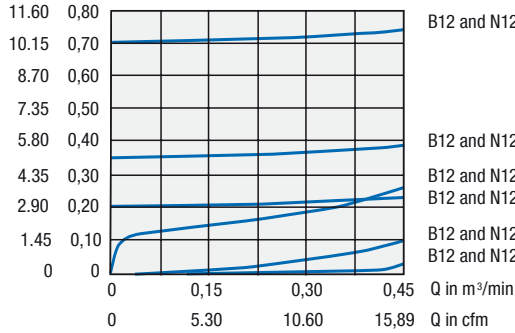
 B08 and N08 (into / out of the tank)
 B12 and N12 (into / out of the tank)

 Δp in PSI Δp in bar

Type SPB 2 (into / out of the tank)

B12 and N12 (out of the tank; pressurised at 0,7 bar / 10 PSI)

B12 and N12 (out of the tank; pressurised at 0,35 bar / 5 PSI)

 B12 and N12 (into the tank; pressurised at 0,7 bar / 10 PSI, 0,35 bar / 5 PSI or 0,2 bar / 3 PSI)
 B12 and N12 (out of the tank; pressurised at 0,2 bar / 3 PSI)

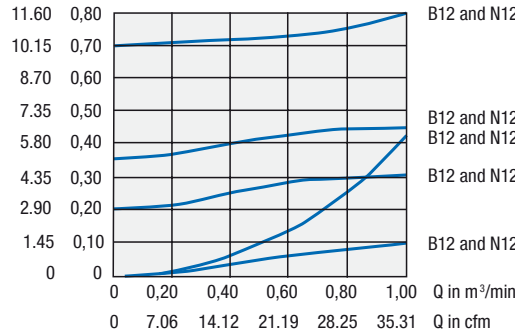
 B12 and N12 (out of the tank; without pressurisation)
 B12 and N12 (into the tank; without pressurisation)

 Δp in PSI Δp in bar

Type SPB 3 (into / out of the tank)

B12 and N12 (out of the tank; pressurised at 0,7 bar / 10 PSI)

B12 and N12 (out of the tank; pressurised at 0,35 bar / 5 PSI)

B12 and N12 (into the tank; pressurised at 0,7 bar / 10 PSI, 0,35 bar / 5 PSI or 0,2 bar / 3 PSI)

B12 and N12 (out of the tank; pressurised at 0,2 bar / 3 PSI)

B12 and N12 (into / out of the tank; without pressurisation)

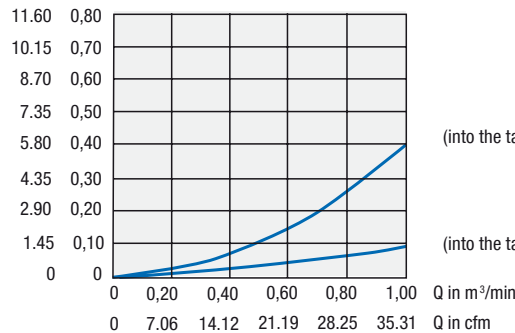
 Δp in PSI Δp in bar

Type SPB 4+5 (into the tank)

(into the tank; pressurised at 0,7 bar / 10 PSI, 0,35 bar / 5 PSI or 0,2 bar / 3 PSI)

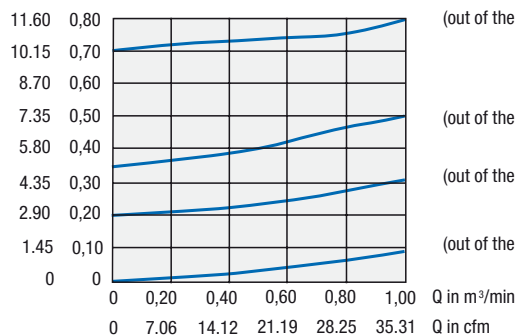
(into the tank; without pressurisation)

 Δp in PSI Δp in bar

Type SPB 4+5 (out of the tank)

(out of the tank; pressurised at 0,7 bar / 10 PSI)

(out of the tank; pressurised at 0,35 bar / 5 PSI)

(out of the tank; pressurised at 0,2 bar / 3 PSI)

(out of the tank; without pressurisation)

Plastic Filler Breather - Type SPBN (Compact Design; Screw-In or Bayonet Version)



Height above tank
- 15 mm / -.59 in
in comparison with
SPB 2

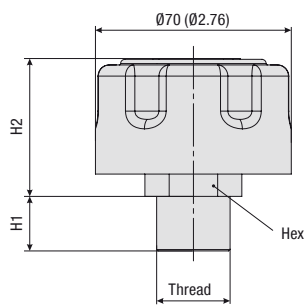

SPBN
Screw-In Version

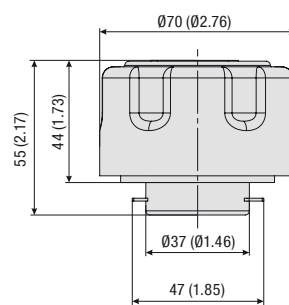

SPBN
Bayonet Version

Characteristics

Designed to be used as filler ports for hydraulic reservoirs, allowing the reservoir to breathe whilst protecting it from contamination found in harsh environments; ideal for applications in which space is limited

Features

- Cap diameter of 070 mm / 02.76 in
- Screw-in version, equipped with male BSP thread (ISO 228) or male NPT thread (ANSI B1.20.1)
- Bayonet version with a six-hole bolt pattern for flange interfaces similar to DIN 24557, part 2
- Operating temperature range:
-40 °C ... +120 °C / -40 °F ... +248 °F

Materials

- Body and cap made of glass-fibre reinforced Polyamide (PA)
- Socket made of Steel, zinc-plated
- Bayonet flange made of Steel, zinc-plated
- Basket made of Steel, zinc-plated or Polyamide (PA)
- Sealings made of NBR (Buna-N®)

Consult STAUFF for alternative materials.

Accessories / Options

- Mounting set including bayonet flange, steel or plastic basket (800 µm), gaskets and bolts
- Pressurisation up to 0,7 bar / 10 PSI
- Air filter element
- Anti-splash feature (for screw-in version only)
- Plastic dipstick with integrated anti-splash feature

Please see page E17 for details.

Maximum Air Flow Rate

- 0,40 m³/min / 14.13 cfm

Please see page E17 for detailed air flow curves.

Oil Displacement

- 400 l/min / 106 US GPM

Installation

- Six-hole bolt pattern for flange interfaces similar to DIN 24557, part 2 (bayonet version with mounting set):

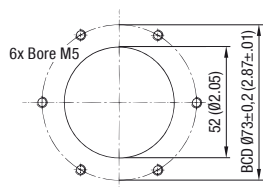

- 6 slotted pan head screws (ISO 1580 M5 x 12-5.8) are included in delivery of the bayonet version with mounting set

Dimensions (Screw-In Version)

Thread	Dimensions (mm/in)		
	H1	H2	Hex
Male G3/4 BSP (ISO 228)	19,5 .77	49,5 1.95	30 1.18
Male G1 BSP (ISO 228)	24 .95	49,5 1.95	36 1.42

Thread	Dimensions (mm/in)		
	H1	H2	Hex
Male 3/4 NPT (ANSI B1.20.1)	19,5 .77	49,5 1.95	30 1.18
Male 1 NPT (ANSI B1.20.1)	24 .95	49,5 1.95	36 1.42

Order Codes

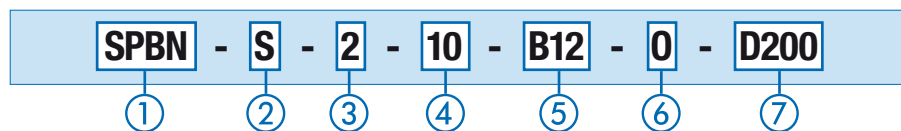

① Type

Plastic Filler Breather (Compact Design) **SPBN**

② Pressurisation

Without pressurisation	S
Pressurised at 0,2 bar / 3 PSI	P1
Pressurised at 0,35 bar / 5 PSI	P2
Pressurised at 0,7 bar / 10 PSI	P3

Please see page E17 for details.

③ Version

Cap diameter 070 mm (02.76 in) **2**

④ Air Filter Element (Material / Micron Rating)

Without air filter element	00
10 µm Foam / PUR (standard option)	10
40 µm Foam / PUR	40

Consult STAUFF for alternative materials / micron ratings.

⑤ Connection

Screw-in version; Male G3/4 thread	B12
Screw-in version; Male G1 thread	B16
Screw-in version; Male 3/4 NPT thread	N12
Screw-in version; Male 1 NPT thread	N16
Bayonet version; Breather only	BS
Bayonet version; Breather including mounting set (with bayonet flange, gaskets and bolts)	BM
Bayonet version; Option BS and metal basket with flange interface (80 mm / 3.15 in)	S080
Bayonet version; Option BS and metal basket with flange interface (100 mm / 3.94 in)	S100
Bayonet version; Option BS and metal basket with flange interface (150 mm / 5.91 in)	S150
Bayonet version; Option BS and metal basket with flange interface (200 mm / 7.87 in)	S200
Bayonet version; Option BS and plastic basket with flange interface (95 mm / 3.74 in)	S095P

⑥ Anti-Splash Feature

With anti-splash feature (standard option)	A
Without anti-splash feature	0

Please see page E17 for details.

⑦ Dipstick

Plastic dipstick (200 mm / 7.88 in) with integrated anti-splash feature	D200
Plastic dipstick (300 mm / 11.81 in) with integrated anti-splash feature	D300
Without dipstick	-

A shorter dipstick length can be achieved by simply cutting down the total length according to individual requirements. Please see page E17 for details.

Plastic Dipstick Anti-Splash Feature

For all Plastic Filler Breathers SPBN, dipsticks made of Polyamide are available as an option. These dipsticks are available in 2 standard lengths of 200 mm / 7.87 in and 300 mm / 11.81 in and equipped with 2 adjustable level indicators in green and red colour. A shorter dipstick length can be achieved by simply cutting down the total length according to individual requirements.

All dipsticks have an integrated anti-splash feature protecting the SPBN from backspilling fluid and avoiding an early breakdown of the air filter element. For Plastic Filler Breathers without dipstick, the anti-splash function can be achieved by an integrated concave baffle.

Please note: When choosing a combination of a dipstick and a basket, the dipstick has to be at least 15 mm / .59 in shorter than the basket.

Special designs and alternative materials available on request.
Please consult STAUFF for further details.

Pressurisation

All Plastic Filler Breathers are also available as pressurised versions with pressure settings of 0,7 bar / 10 PSI, 0,35 bar / 5 PSI or 0,2 bar / 3 PSI. In order to achieve an air flow, the actual tank pressure has to exceed the chosen pressure setting of the Plastic Filler Breather.

When the fluid level inside the reservoir rises, no air is expelled from the reservoir until the pressurisation level is reached. When the fluid level inside the reservoir falls, the tank pressure drops and air is drawn into the reservoir.

Due to less breathing, the service life of a filler breather and the oil can be increased by using the pressurisation feature. It also minimizes foaming and cavitation, and provides additional protection from moisture entering the reservoir and which causes erosion and oil degradation.

Mounting Set for Baskets (including Bayonet Flange, Gaskets and Bolts)

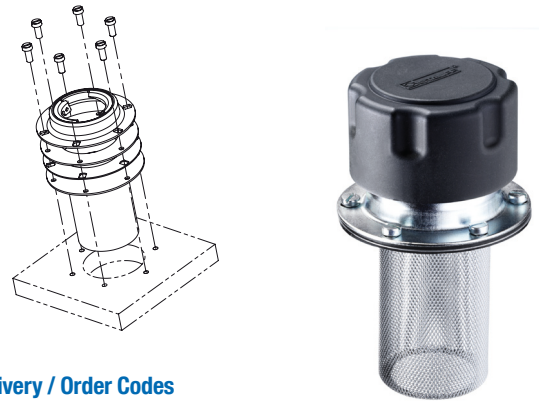

Scope of Delivery / Order Codes

Mounting sets for baskets include the following components:

- 6 slotted pan head screws made of steel, zinc-plated (ISO 1580 M5 x 12-5.8)
- Bayonet flange made of steel, zinc-plated, with six-hole bolt pattern acc. to DIN 24557, part 2
- 2 gaskets made of NBR (Buna-N®) - one for underneath and one for on top of the basket
- Metal or plastic basket (only if required):

Metal basket (80 mm / 3.15 in):	S-080-M-F-SPBN-BS-NBR
Metal basket (100 mm / 3.94 in):	S-100-M-F-SPBN-BS-NBR
Metal basket (150 mm / 5.91 in):	S-150-M-F-SPBN-BS-NBR
Metal basket (200 mm / 7.87 in):	S-200-M-F-SPBN-BS-NBR
Plastic basket (95 mm / 3.74 in):	S-095-P-F-SPBN-BS-NBR
Without basket:	Adapter-SPBN-BM-NBR

Mounting sets can also be ordered as part of a complete breather assembly.
Please see page E16 for details.

Further Accessories / Options



Extended Bayonet Flange - Type EBF
Suitable for SPBN; Bayonet Version
(See page E25 for details)

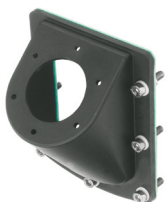

Side Mount Bracket (Polyamide) - Type ASMB-1
Suitable for SPBN; Bayonet Version
(See page E24 for details)



Weld Riser - Type WR
Suitable for SPBN; Bayonet Version
(See page E25 for details)



Side Mount Bracket (Aluminium) - Type ASMB-2
Suitable for SPBN; Bayonet Version
(See page E24e for details)

Pressure Drop Flow Curves Plastic Filler Breathers

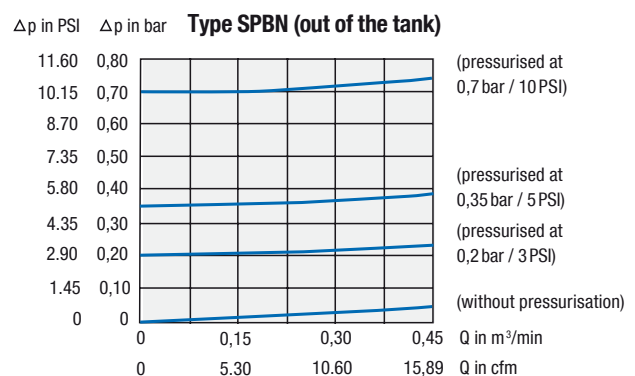
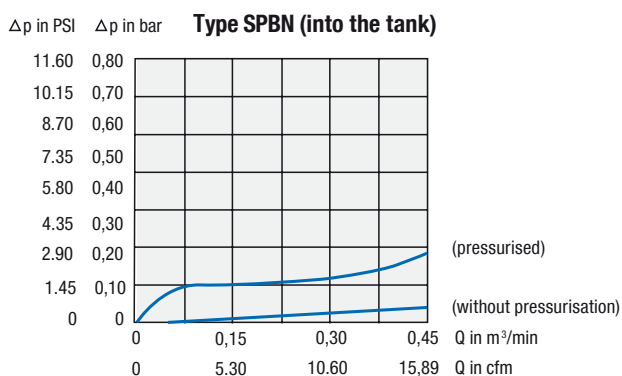

Metal Filler Breather - Type SMBT-47 (Screw-In Version)

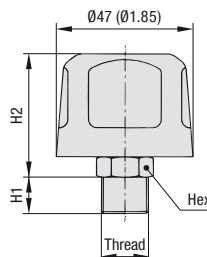

Characteristics

Designed to be used as filler ports for hydraulic reservoirs, allowing the reservoir to breathe whilst protecting it from contamination found in harsh environments

Features

- Cap diameter of Ø47 mm / Ø1.85 in
- Screw-in version, equipped with male BSP thread (ISO 228) or male NPT thread (ANSI B1.20.1)

Materials

- Breather cap made of Steel, zinc/nickel-plated (Fe/Zn Ni 6) and free of hexavalent chromium CrVI (standard option); chrome-plated and epoxy-coated versions available
- Threaded socket made of Steel, zinc-plated

Consult STAUFF for alternative materials.

Accessories / Options

- Air filter element

Maximum Air Flow Rate

- 0,40 m³/min / 14.13 cfm

Consult STAUFF for detailed air flow curves.

Oil Displacement

- 400l/min / 106 US GPM

Dimensions

Thread	Dimensions (mm/in)		
	H1	H2	Hex
Male G1/4 BSP (ISO 228)	10 .39	41 2.38	17 .67
Male G3/8 BSP (ISO 228)	13 .51	41 2.38	19 .74
Male G1/2 BSP (ISO 228)	14 .55	41 2.38	22 .88

Thread	Dimensions (mm/in)		
	H1	H2	Hex
Male 1/4 NPT (ANSI B1.20.1)	13 .51	41 2.38	17 .67
Male 3/8 NPT (ANSI B1.20.1)	15 .59	41 2.38	19 .74

Consult STAUFF for alternative threads.

Order Codes

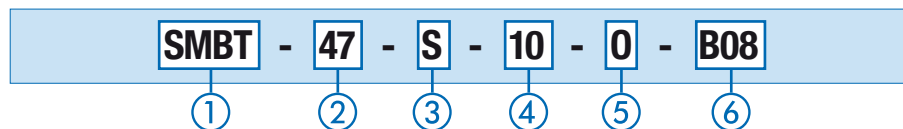

① Type / Version

Metal Filler Breather; Screw-in version **SMBT**

② Cap Diameter / Material / Surface Finishing

Cap diameter Ø47 mm (Ø1.85 in); Breather cap made of Steel, zinc/nickel-plated (standard option)	47
Cap diameter Ø47 mm (Ø1.85 in); Breather cap made of Steel, chrome-plated	47C
Cap diameter Ø47 mm (Ø1.85 in); Breather cap made of Steel, epoxy-coated	47E

③ Label

With STAUFF logo (standard option)	S
Neutral design without any logo	N

④ Air Filter Element (Material / Micron Rating)

Without air filter element	00
3 µm Filter Paper	03
10 µm Foam / PUR (standard option)	10
40 µm Foam / PUR	40

Consult STAUFF for alternative materials / micron ratings.

⑤ Pressurisation

Without pressurisation (standard option) **0**

No pressurisation available for this cap diameter.

⑥ Connection Thread (Male)

G1/4	B04
G3/8	B06
G1/2	B08
1/4 NPT	N04
3/8 NPT	N06

Consult STAUFF for alternative threads.

Metal Filler Breather - Type SMBB-47 (Bayonet Version)

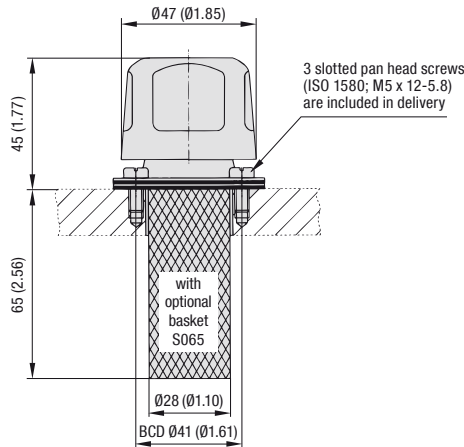

Characteristics

Designed to be used as filler ports for hydraulic reservoirs, allowing the reservoir to breathe whilst protecting it from contamination found in harsh environments

Features

- Cap diameter of Ø47 mm / Ø1.85 in
- Bayonet version with a three-hole bolt pattern

Materials

- Breather cap made of Steel, zinc/nickel-plated (Fe/Zn Ni 6) and free of hexavalent chromium CrVI (standard option); chrome-plated and epoxy-coated versions available
- Bayonet flange made of Steel, zinc-plated
- Basket made of Steel, zinc-plated
- Sealings made of Cork

Consult STAUFF for alternative materials.

Accessories / Options

- Metal basket (800 µm)
- Air filter element

Maximum Air Flow Rate

- 0,40 m³/min / 14.13 cfm

Consult STAUFF for detailed air flow curves.

Oil Displacement

- 400 l/min / 106 US GPM

Installation

- Three-hole bolt pattern for flange interfaces:

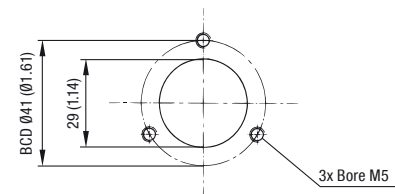

- 3 slotted pan head screws (ISO 1580 M5 x 12-5.8) are included in delivery; can be replaced by regular M5 bolts, if required

Order Codes

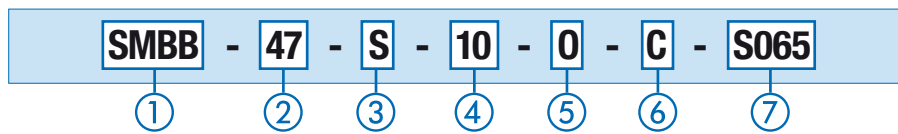

① Type / Version

Metal Filler Breather; Bayonet version **SMBB**

② Cap Diameter / Material / Surface Finishing

Cap diameter Ø47 mm (Ø1.85 in); Breather cap made of Steel, zinc/nickel-plated (standard option) **47**

Cap diameter Ø47 mm (Ø1.85 in); Breather cap made of Steel, chrome-plated **47C**

Cap diameter Ø47 mm (Ø1.85 in); Breather cap made of Steel, epoxy-coated **47E**

③ Label

With STAUFF logo (standard option) **S**

Neutral design without any logo **N**

④ Air Filter Element (Material / Micron Rating)

Without air filter element **00**

3 µm Filter Paper **03**

10 µm Foam / PUR (standard option) **10**

40 µm Foam / PUR **40**

Consult STAUFF for alternative materials / micron ratings.

⑤ Pressurisation

Without pressurisation (standard option) **0**

No pressurisation available for this cap diameter.

⑥ Sealing Material

Cork (standard option) **C**

⑦ Basket Option

Metal basket (65 mm / 2.56 in) **S065**

Without basket **0**

Metal Filler Breather - Type SMBT-80 (Screw-In Version)

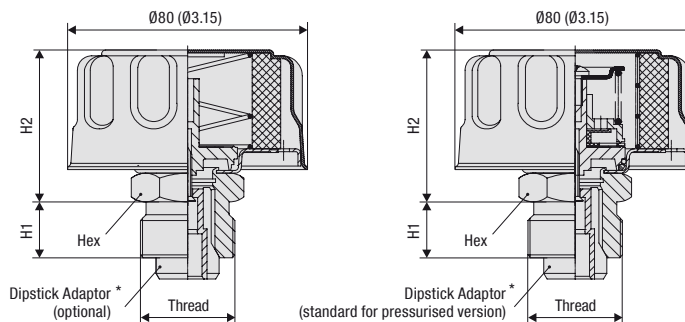

Without Pressurisation

Pressurised

* Please note: The dipstick adaptor is not available for connection threads G1/2 and 1/2 NPT.

Characteristics

Designed to be used as filler ports for hydraulic reservoirs, allowing the reservoir to breathe whilst protecting it from contamination found in harsh environments

Features

- Cap diameter of Ø80 mm / Ø3.15 in
- Screw-in version, equipped with male BSP thread (ISO 228) or male NPT thread (ANSI B1.20.1)

Materials

- Breather cap made of Steel, zinc/nickel-plated (Fe/Zn Ni 6) and free of hexavalent chromium CrVI (standard option); chrome-plated and epoxy-coated versions available
- Threaded socket made of Steel, zinc-plated
- Dipstick adaptor made of Polyamide (PA)

Consult STAUFF for alternative materials.

Accessories / Options

- Pressurisation up to 0,7 bar / 10 PSI
- Air filter element
- Dipstick adaptor suitable for plastic dipstick DS-1 (not for connection threads G1/2 and 1/2 NPT)
- Plastic dipstick DS-1 with integrated anti-splash feature (not for connection threads G1/2 and 1/2 NPT)

Maximum Air Flow Rate

- 0,45 m³/min / 15,89 cfm

Consult STAUFF for detailed air flow curves.

Oil Displacement

- 450 l/min / 119 US GPM

Dimensions

Thread	Dimensions (mm/in)		
	H1	H2	Hex
Male G1/2 BSP (ISO 228)	14 .55	54 2.13	24 .94
Male G3/4 BSP (ISO 228)	16 .63	54 2.13	30 1.18
Male G1 BSP (ISO 228)	19 .75	54 2.13	36 1.42

Thread	Dimensions (mm/in)		
	H1	H2	Hex
Male 1/2 NPT (ANSI B1.20.1)	14 .51	52,5 2.07	24 .94
Male 3/4 NPT (ANSI B1.20.1)	16 .59	52,5 2.07	30 1.18
Male G1 NPT (ANSI B1.20.1)	19 .75	52,5 2.07	36 1.42

Order Codes

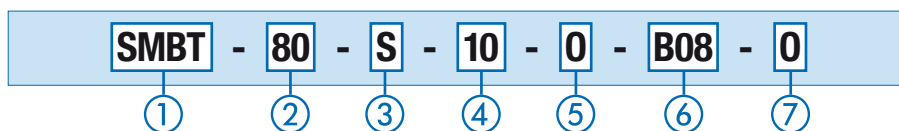

① Type / Version

Metal Filler Breather; Screw-in version **SMBT**

② Cap Diameter / Material / Surface Finishing

Cap diameter Ø80 mm (Ø3.15 in); Breather cap made of Steel, zinc/nickel-plated (standard option) **80**
 Cap diameter Ø80 mm (Ø3.15 in); Breather cap made of Steel, chrome-plated **80C**
 Cap diameter Ø80 mm (Ø3.15 in); Breather cap made of Steel, epoxy-coated **80E**

③ Label

With STAUFF logo (standard option) **S**
 Neutral design without any logo **N**

④ Air Filter Element (Material / Micron Rating)

Without air filter element **00**
 3 µm Filter Paper **03**
 10 µm Foam / PUR (standard option) **10**
 40 µm Foam / PUR **40**

Consult STAUFF for alternative materials / micron ratings.

⑤ Pressurisation

Without pressurisation (standard option) **0**
 Pressurised at 0,35 bar / 5 PSI **P2**
 Pressurised at 0,7 bar / 10 PSI **P3**

⑥ Connection Thread (Male)

G1/2 **B08**
 G3/4 **B12**
 G1 **B16**
 1/2 NPT **N08**
 3/4 NPT **N12**
 1 NPT **N16**

Consult STAUFF for alternative threads.

⑦ Dipstick

Without dipstick (standard option) **0**
 With dipstick adaptor suitable for dipstick DS-1 (not for connection threads G1/2 and 1/2 NPT) **A**
 With dipstick adaptor and plastic dipstick DS-1 (300 mm / 11.81 in) with integrated anti-splash feature (not for connection threads G1/2 and 1/2 NPT) **D300**

A shorter dipstick length can be achieved by simply cutting down the total length according to individual requirements.

Please note: The dipstick adaptor is required for the subsequent installation of plastic dipsticks DS-1 (see page E14 for details), and is included in delivery when ordering a pressurised version. The dipstick adaptor is not available for connection threads G1/2 and 1/2 NPT.

Metal Filler Breather - Type SMBB-80 (Bayonet Version)

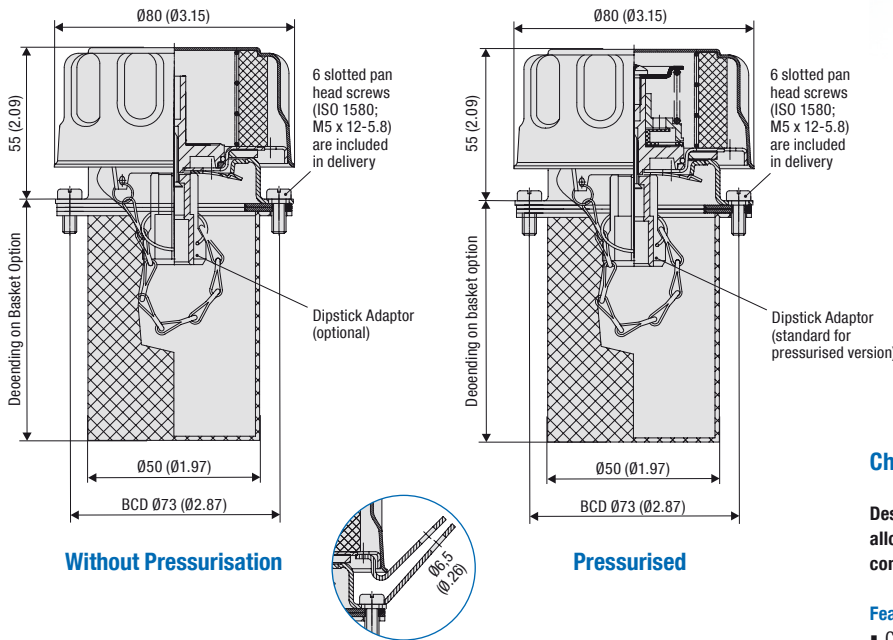

Without Pressurisation

Pressurised

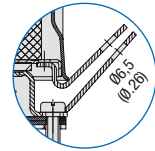

Locking Feature

(Recommended mounting space: Ø126 mm / Ø4.96 in)



Characteristics

Designed to be used as filler ports for hydraulic reservoirs, allowing the reservoir to breathe whilst protecting it from contamination found in harsh environments

Features

- Cap diameter of Ø80 mm / Ø3.15 in
- Bayonet version with a six-hole bolt pattern for flange interfaces similar to DIN 24557, part 2

Materials

- Breather cap made of Steel, zinc/nickel-plated (Fe/Zn Ni 6) and free of hexavalent chromium CrVI (standard option); chrome-plated and epoxy-coated versions available
- Bayonet flange made of Steel, zinc-plated
- Basket made of Steel, zinc-plated or Polyamide (PA)
- Dipstick adaptor made of Polyamide (PA)
- Sealings made of Cork (for filler breathers without pressurisation) or NBR (Buna-N®) (for pressurised filler breathers)

Consult STAUFF for alternative materials.

Accessories / Options

- Metal or plastic basket (800 µm)
- Pressurisation up to 0,7 bar / 10 PSI
- Air filter element
- Locking feature
- Dipstick adaptor (suitable for plastic dipstick DS-1)
- Plastic dipstick with integrated anti-splash feature

Maximum Air Flow Rate

- 0,45 m³/min / 15.89 cfm

Consult STAUFF for detailed air flow curves.

Oil Displacement

- 450 l/min / 119 USGPM

Installation

- Six-hole bolt pattern for flange interfaces similar to DIN 24557, part 2:

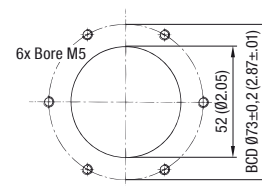

- 6 slotted pan head screws (ISO 1580 M5 x 12-5.8) are included in delivery; can be replaced by regular M5 bolts, if required

Order Codes

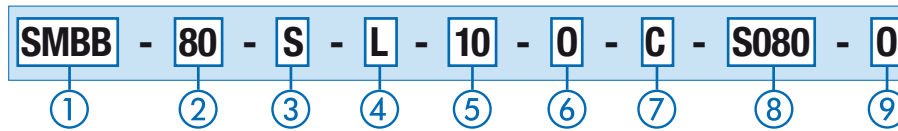

1 Type / Version

 Metal Filler Breather; Bayonet version **SMBB**

2 Cap Diameter / Material / Surface Finishing

Cap diameter Ø80 mm (Ø3.15 in); Breather cap made of Steel, zinc/nickel-plated (standard option)	80
Cap diameter Ø80 mm (Ø3.15 in); Breather cap made of Steel, chrome-plated	80C
Cap diameter Ø80 mm (Ø3.15 in); Breather cap made of Steel, epoxy-coated	80E

3 Label

With STAUFF logo (standard option)	S
Neutral design without any logo	N

4 Locking Feature

Without locking feature (standard option)	0
With locking feature (see drawing above)	L

5 Air Filter Element (Material / Micron Rating)

Without air filter element	00
3 µm Filter Paper	03
10 µm Foam / PUR (standard option)	10
40 µm Foam / PUR	40

Consult STAUFF for alternative materials / micron ratings.

6 Pressurisation

Without pressurisation (standard option)	0
Pressurised at 0,35 bar / 5 PSI	P2
Pressurised at 0,7 bar / 10 PSI	P3

7 Sealing Material

Cork (for filler breathers without pressurisation)	C
NBR (Buna-N®) (for pressurised filler breathers)	B

8 Basket Option

Without basket	0
Plastic basket (95 mm / 3.74 in) (standard option)	S095P
Metal basket (80 mm / 3.15 in)	S080
Metal basket (100 mm / 3.94 in)	S100
Metal basket (150 mm / 5.91 in)	S150
Metal basket (200 mm / 7.87 in)	S200
Heavy duty metal basket (200 mm / 7.87 in)	S200HD

9 Dipstick

Without dipstick (standard option)	0
Dipstick adaptor (suitable for dipstick DS-1)	A
With dipstick adaptor and plastic dipstick DS-1 (300 mm / 11.81 in) with integrated anti-splash feature	D300

A shorter dipstick length can be achieved by simply cutting down the total length according to individual requirements.

Please note: The dipstick adaptor is required for the subsequent installation of plastic dipsticks DS-1 (see page E14 for details), and is content of delivery when ordering a pressurised version.

Metal Breather ▪ Type SMBP-80 (Push-On Version)

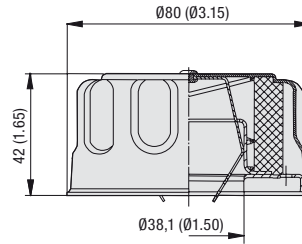

Characteristics

Designed to be used as filler ports for hydraulic reservoirs, allowing the reservoir to breathe whilst protecting it from contamination found in harsh environments

Features

- Cap diameter of 80 mm / 0.3.15 in
- Push-on version, suitable for pipe diameters up to 38 mm/ 1.50 in

Materials

- Breather cap made of Steel, zinc/nickel-plated (Fe/Zn Ni 6) and free of hexavalent chromium CrVI (standard option); chrome-plated and epoxy-coated versions available

Consult STAUFF for alternative materials.

Accessories / Options

- Air filter element

Maximum Air Flow Rate

- 0,45 m³/min / 15.89 cfm

Consult STAUFF for detailed air flow curves.

Oil Displacement

- 450 l/min / 119 US GPM

Order Codes

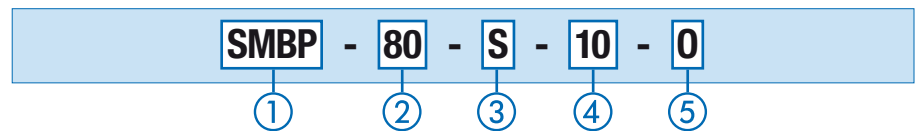

① Type / Version

Metal Breather; Push-on version	SMBP
---------------------------------	-------------

② Cap Diameter / Material / Surface Finishing

Cap diameter 80 mm (0.3.15 in); Breather cap made of Steel, zinc/nickel-plated (standard option)	80
Cap diameter 80 (0.3.15 in); Breather cap made of Steel, chrome-plated	80C
Cap diameter 80 (0.3.15 in); Breather cap made of Steel, epoxy-coated	80E

③ Label

With STAUFF logo (standard option)	S
Neutral design without any logo	N

④ Air Filter Element (Material / Micron Rating)

Without air filter element	00
10 µm Foam / PUR (standard option)	10
40 µm Foam / PUR	40

Consult STAUFF for alternative materials / micron ratings.

⑤ Dipstick

Without dipstick (standard option)	0
------------------------------------	----------

Lockable Metal Filler Breather ▀ Type SMBL (Clamping, Threaded and Push-On Version)

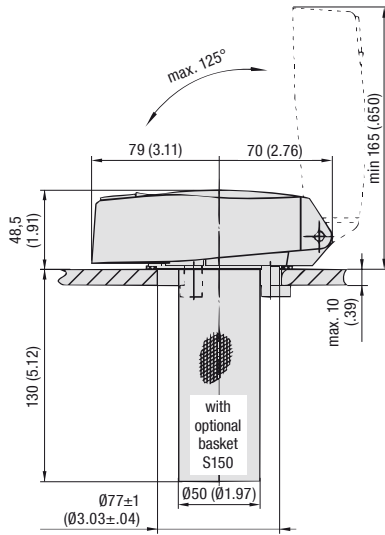

Clamping Version

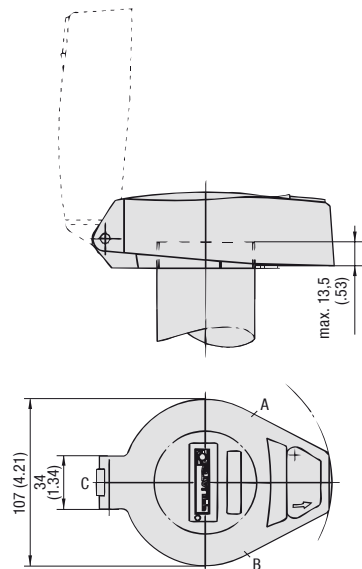

Threaded Version

Recommended mounting space: $\varnothing 162$ mm / $\varnothing 6.38$ in
2 locking screws M6 x 6 (DIN 916) at positions A and B

Push-On Version

3 locking screws M6 x 6 (DIN 916) at positions A, B and C



Clamping version
with metal basket
(150 mm / 5.91 in)

Characteristics

Designed to be used as lockable filler ports for hydraulic reservoirs, allowing the reservoir to breathe whilst protecting it from contamination found in harsh environments

Features

- Available as clamping version (with 3 clamping jaws), as threaded version (with female BSP thread) or push-on version, suitable for stand pipe mounting with pipe diameters up to 77.5 mm / 3.05 in (secured by 3 locking screws)
- Key-lockable cap (2 keys included)
- Lock protected by rotating flap
- Operating temperature range: -30 °C ... +100 °C / -22 °F ... +212 °F
- Air flow in both directions, one direction only or no direction

Materials

- Breather cap made of Aluminium, lacquered (light-grey, RAL 9022)
- Breather body made of Aluminium, zinc-plated
- Basket made of Steel, zinc-plated or Polypropylene (PP)
- Sealings made of NBR (Buna-N®) (standard option); FPM (Viton®) sealed version available

Consult STAUFF for alternative materials.

Accessories / Options

- Metal or (telescopic) plastic basket (800 µm)
- Air filter element

Order Codes

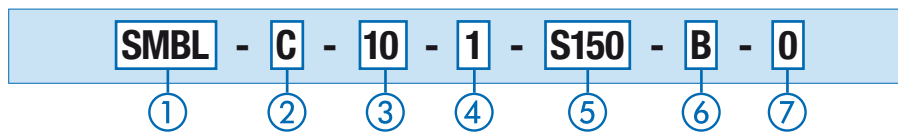

① Type

Lockable Metal Filler Breather **SMBL**

② Version

Clamping version with 3 clamping jaws; Installation to a tank mounting hole of $\varnothing 77 \pm 1$ mm / $\varnothing 3.03 \pm 0.04$ in **C**
Threaded version with female G2 BSP thread **B32**
Threaded version with female G2-1/2 BSP thread **B40**
Push-on version for stand pipe mounting **P**

③ Air Filter Element (Material / Micron Rating)

Without air filter element **00**
10 µm Foam / PUR (standard option) **10**
40 µm Foam / PUR **40**

Consult STAUFF for alternative materials / micron ratings.

④ Air Flow

Air flow in both directions (standard option) **1**
No air flow **2**
Air flow only into the tank **3**

⑤ Basket Option

Without basket **0**
Metal basket (150 mm / 5.91 in) **S150**
Plastic basket (80 mm / 3.15 in) **S080**
Telescopic plastic basket (max. 205 mm / max. 8.07 in) **S200**

The baskets of the SMBB 47/80 series cannot be used in conjunction with the SMBL series.

⑥ Sealing Material

NBR (Buna-N®) (standard option) **B**
FPM (Viton®) **V**

⑦ Cap Design

Breather cap made of Aluminium, lacquered (light-grey, RAL 9022) **0**

Side Mount Bracket - Type ASMB-1 (Polyamide Version)

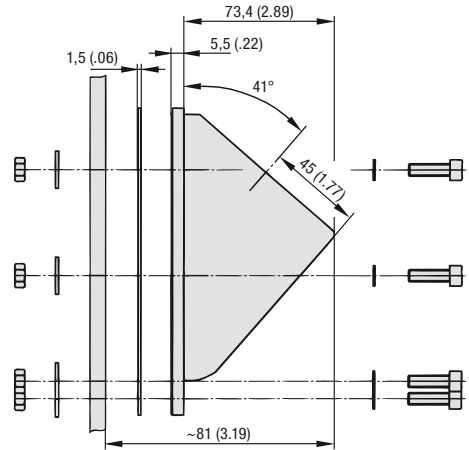
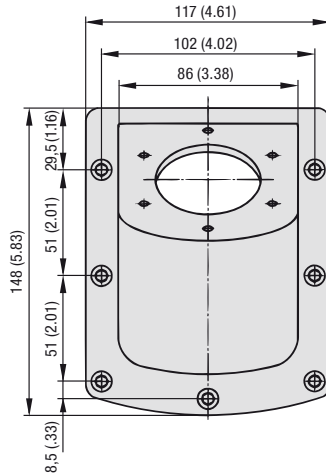
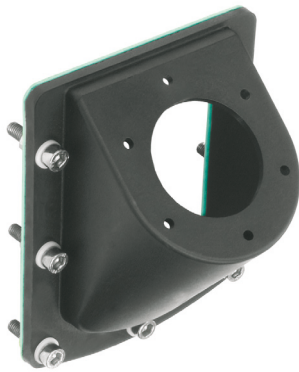

Characteristics

Lateral fastening of filler breathers with a six-hole flange connection similar to DIN 24557, part 2 to vertical or sloped walls of hydraulic reservoirs; ideal for applications in which space is limited

Suitability

- Suitable for Plastic Filler Breathers SPB 5 and SPBN (bayonet version) and Metal Filler Breathers SMBB 80

Materials

- Mounting bracket made of Polyamide (PA)
- Seal plate made of Klingerit
- Screws and hex nuts made of Steel, zinc-plated
- Washers made of Steel, zinc-plated
- Plastic spacers made of Polyamide (PA)

Scope of Delivery

- 1 mounting bracket
- 1 seal plate
- 7 socket cap screws M6 x 25 (ISO 4762)
- 7 plastic spacers 6,4 (DIN 125)
- 7 hex nuts M6 (ISO 4032)
- 7 washers 6,4 (DIN 9021)
- 6 sheet metal screws 4,8x13 (ISO 7049)

Installation

- Bolted to the side of the reservoir
- Bayonet flange of filler breather is placed on top
- Flange interface similar to DIN 24557, part 2 with 6 equally spaced mounting bores $\varnothing 4,5$ mm / $\varnothing .18$ in (BCD $\varnothing 71 \pm 0,2$ mm / $\varnothing 2.80 \pm .01$ in)

Order Codes

SMBB-ASMB - 1	
①	②

① Type

Side Mount Bracket **SMBB-ASMB**

② Housing Material

Polyamide (PA) **1**

Side Mount Bracket - Type ASMB-2 (Aluminium Version)

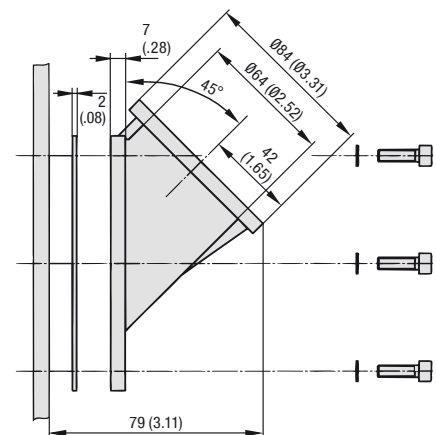
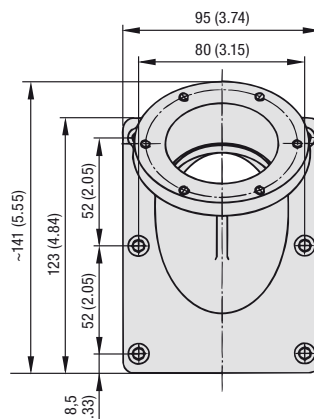

Characteristics

Lateral fastening of filler breathers with a six-hole flange connection similar to DIN 24557, part 2 to vertical or sloped walls of hydraulic reservoirs; ideal for applications in which space is limited

Suitability

- Suitable for Plastic Filler Breathers SPB 5 and SPBN (bayonet version) and Metal Filler Breathers SMBB 80

Materials

- Mounting bracket made of Aluminium
- Seal plate made of Flexolid
- Screws made of Steel, zinc-plated
- Plastic spacers made of Klingerit

Scope of Delivery

- 1 mounting bracket
- 1 seal plate
- 6 socket cap screws M6 x 20 (ISO 4762)
- 6 plastic spacers 6,4 (DIN 125)

Installation

- Bolted to the side of the reservoir
- Bayonet flange of filler breather is placed on top
- Flange interface similar to DIN 24557, part 2 with 6 equally spaced bores M5 (BCD $\varnothing 73 \pm 0,2$ mm / $\varnothing 2.87 \pm .01$ in)

Order Codes

SMBB-ASMB - 2	
①	②

① Type

Side Mount Bracket **SMBB-ASMB**

② Housing Material

Aluminium **2**

Extended Bayonet Flange ■ Type EBF

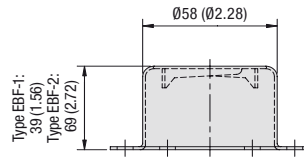
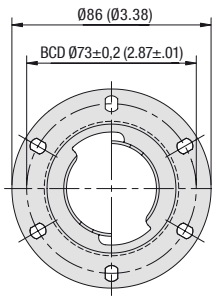

Order Codes

EBF - 2

① ②

① Type

Extended Bayonet Flange **EBF**

② Size

Total height of 39 mm (1.56 in) **1**
 Total height of 69 mm (2.72 in) **2**

Installation

- Six-hole bolt pattern for flange interfaces similar to DIN 24557, part 2:

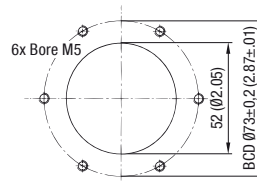

- Supplied without gaskets and bolts

Characteristics

Designed to raise filler breathers either 39 mm / 1.56 in or 69 mm / 2.72 in above the actual mounting surface of the reservoir to prevent contamination from blocking the filter element

Suitability

- Suitable for Metal Filler Breathers SMBB 80 and Plastic Filler Breathers SPBN (bayonet version)
- Replaces the existing bayonet flanges of these breathers

Materials

- Bayonet flange made of Steel, zinc-plated

Weld Riser ■ Type WR

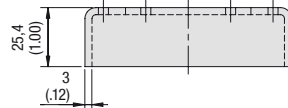
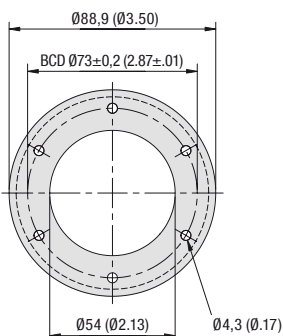

Order Codes

WR - 1

① ②

① Type

Weld Riser **WR**

② Size

Total height of 25,4 mm (1.00 in) **1**

Materials

- Weld riser made of Steel, untreated

Installation

- Welded to the top of the reservoir
- No requirement to drill and tap on the reservoir
- Bayonet flange of filler breather is placed on top

Characteristics

Designed to raise filler breathers 25,4 mm / 1.00 in above the actual mounting surface of the reservoir to prevent contamination from blocking the filter element whilst eliminating the requirement to drill and tap on the reservoir

Suitability

- Suitable for Metal Filler Breathers SMBB 80 as well as Plastic Filler Breathers SPB 5 and SPBN (bayonet version) and all components with a six-hole flange connection similar to DIN 24557, part 2

**Plastic Filler Breather - Type SES
(Screw-In or Welded Versions)**

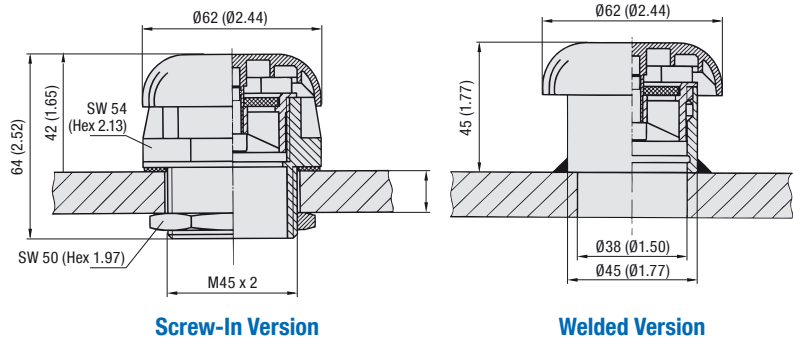

Screw-In Version

Welded Version

Characteristics

Designed to be used as filler ports for hydraulic reservoirs, allowing the reservoir to breathe whilst protecting it from contamination found in harsh environments

Features

- Cap diameter of 62 mm / 2.44 in
- Screw-in version, equipped with male Metric ISO thread M45 x 2 and lock nut, or welded version with welding socket made of Steel (1.0718), untreated
- Supplied with 45 µm air filter element

Materials

- Breather cap made of Polyamide (PA)
- Breather body / stud made of Polyamide (PA)
- Nut (type SES 1) made of Steel (1.0718); Polyamide (PA) available on request
- Welding socket (type SES 2) made of Steel (1.0718), untreated; Stainless Steel (V2A) available on request
- Air filter element made of Sintered Bronze
- Basket made of Polyamide (PA)
- Dipstick made of Steel (1.0718)
- Sealings made of NBR (Buna-N®)

Consult STAUFF for alternative materials.

Accessories / Options

- Plastic basket (300 µm)
- Metal dipstick

Maximum Air Flow Rate

- 0,30 m³/min / 10.60 cfm

Consult STAUFF for detailed air flow curves.

Oil Displacement

- 300l/min / 79USGPM

Order Codes



① Type

Plastic Filler Breather **SES**

② Version

Screw-in version **1**
Welded version **2**

③ Basket / Dipstick Option

Plastic basket (81 mm / 3.19 in)	S
Metal dipstick (300 mm / 11.81 in)	M300
Metal dipstick (500 mm / 19.69 in)	M500
Without basket / dipstick	-

Accessories

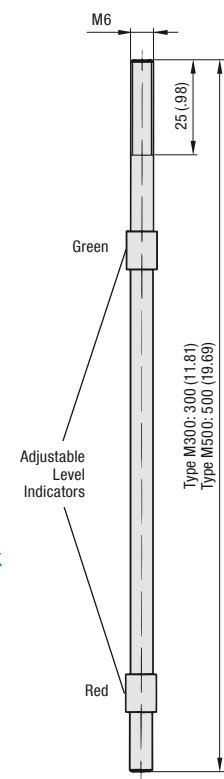
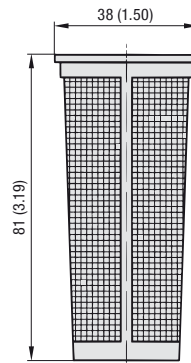

Introduction

Fluid Level and Temperature Indicators

Tank Filler Breathers

Particle and Desiccant Breathers

Suction Strainers

Diffusers

Appendix



Catalogue 10

STAUFF Hydraulic Accessories

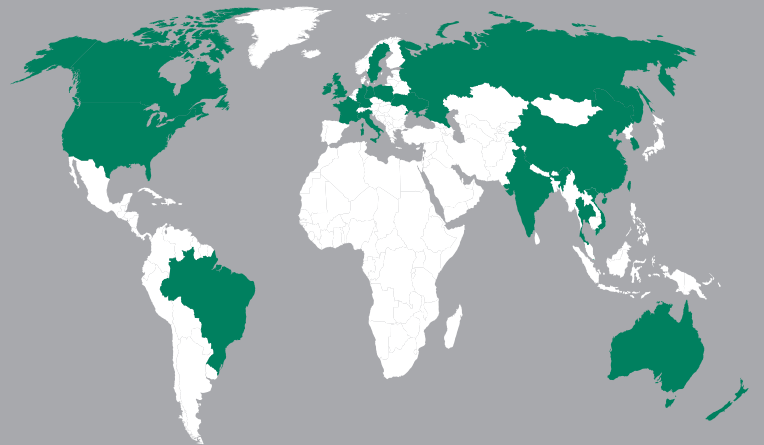

Germany

Walter Stauffenberg GmbH & Co. KG
Im Ehrenfeld 4
58791 Werdohl

STAUFF products and services are globally available through wholly-owned subsidiaries and a tight network of authorised distributors and representatives in all major industrial regions of the world.

Contact STAUFF:

www.stauff.com/contact