



# M Tube Fitting<sup>®</sup>

Mechanically Outstanding for Performance<sup>™</sup>



Stainless Steel

- 1/16 to 2 in. OD
- 2 to 50 mm OD



Alloy 600, 625, 825, C276

**Proven Performance  
Over 25 Years In Supply**



Carbon Steel, Brass

**ASME N, NPT, NS Stamp Holder**

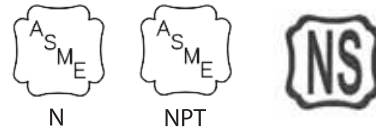

Installation Tools

<p>Quality System Certificate</p>	<p>HSE Management Certificates</p>	<p>Nuclear Quality System Certificates</p>	<p>Type Approval Certificates</p>	<p>www.hsmecorp.com</p> <p><b>HSME<sup>®</sup></b> since 1976 Registered Trade Mark</p>
-----------------------------------	------------------------------------	--	-----------------------------------	---



# M Tube Fitting<sup>®</sup>

Mechanically Outstanding for Performance<sup>™</sup>

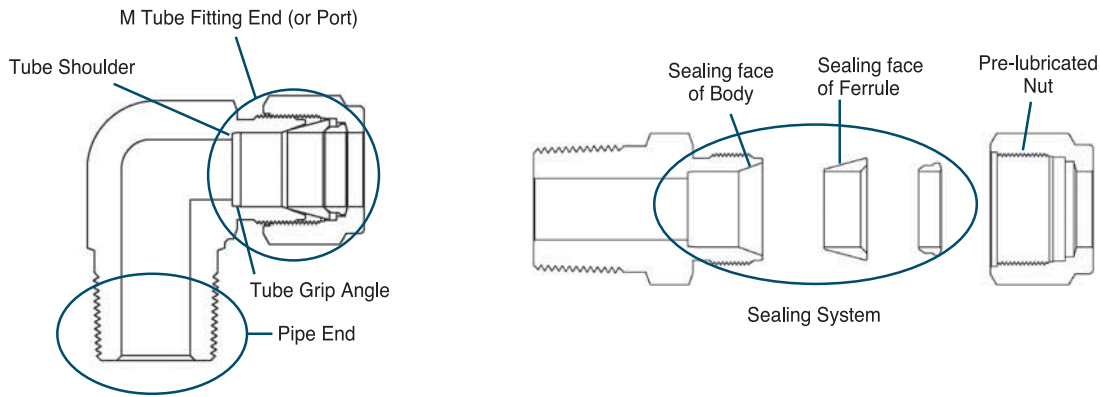

## M Tube Fitting Design Standards & Codes

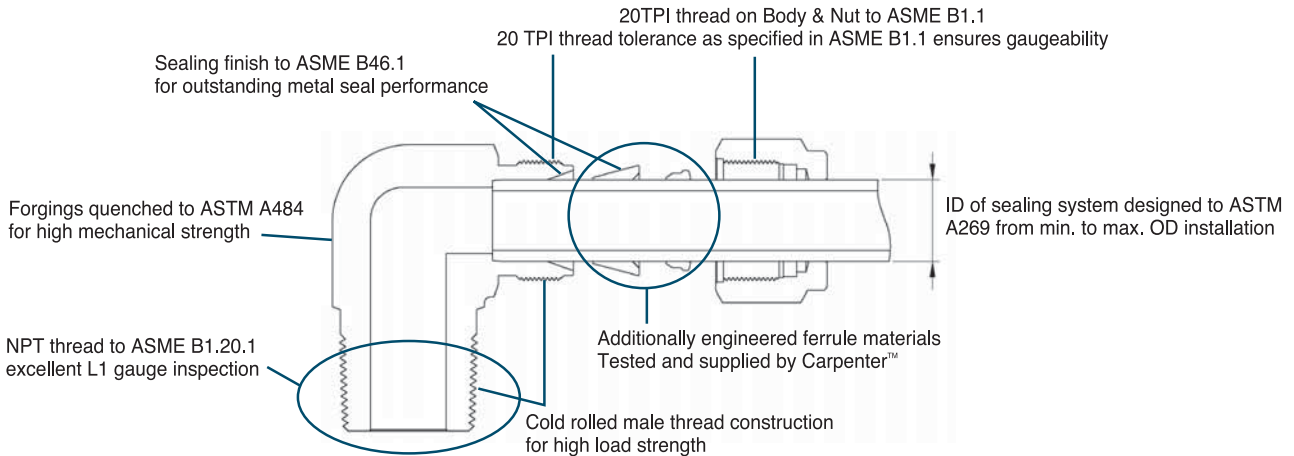

### Gauge-Ability

Make-up 1 1/4 turns advance NUT by 1.25 pitches from finger-tight position.  
On 20 TPI, 1.25 pitches travel 1/16 in. (1.5875 mm) make-up distance for Gaugeability

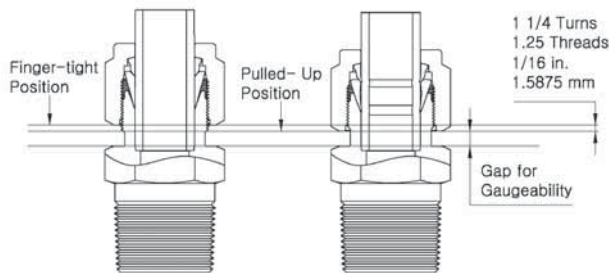

### Mechanically Outstanding for Leak-tight Metal Seal Performance

M Tube Fittings provide metal to metal sealing. M tube fittings are designed to exceed the requirements of industrial codes and standards with additional Cutting-Edge Engineering on swaging action and sealing integrity.

### Interchangeability

Two ferrule geometry is a generic design that has been used in industry since 1940th. M Tube Fittings are interchangeable with these products provided they are designed to the codes and standards referred above along with the generic geometry.

### Pressure-Temperature Ratings

M Tube Fitting Pressure-Temperature Ratings designed to ASME B31.3 Process Piping Code.

**Tube to Tube Union**

**AU**  
Union  **15**

**AUR**  
Reducing Union  **16**

**AUB**  
Bulkhead Union  **17**

**ABR**  
Bulkhead  
Elbow Union  **18**

**ABL**  
Bulkhead  
Elbow Union  **18**

**AUA**  
AN Union  **19**

**AUBA**  
AN Bulkhead  
Union  **19**

**AL**  
Union Elbow  **20**

**ALR**  
Reducing Union Elbow  **21**

**AT**  
Union Tee  **21,22**

**ATR**  
Reducing Union Tee  **22,23**

**AX**  
Union Cross  **24**

**AXR**  
Reducing Union Cross  **25**

**Tube to Male Pipe**

Male Connector

**AMCT/ART**  
Bored-Through  
Fittings  **25**

**AMC-N**  
Male NPT Connector  **26,27**

**AMCB-N**  
Bulkhead  
Male NPT Connector  **28**

**AMC-R**  
Male BSPT Connector  **29,30**

**AMC-G**  
Male ISO Parallel  
Connector  **31,33**

**AMC-GB**  
Male ISO Parallel  
Connector  **31,33**

**9PBN-G**  
**9PBV-G**  
Bonded Gasket  **32**

**9PP-G**  
Copper Gasket  **32**

**AMC-UF**  
Non-Positionable  
SAE Male Connector  **34**

**AMC-UO**  
O-Seal SAE Male  
Connector  **36**

**AMC-NO**  
O-Seal NPT  
Male Connector  **36**

Male Elbows

**ALBM-N**  
45° Male NPT  
Elbow  **37**

**ALBS-UP**  
Positionable 45°  
SAE Male Elbow  **37**

**ALM-N**  
Male NPT Elbow  **38,39**

**ALM-R**  
Male BSPT  
Elbow  **40,41**

**ALM-GR**  
Positionable  
Male ISO  
Parallel Thread  
Elbow  **42**

**ALS-UP**  
Positionable  
SAE Male Elbow  **43**

**ATRS-UP**  
Positionable  
SAE Male Run Tee  **44**

**ATBS-UP**  
Positionable  
SAE Male Branch Tee  **44**

**ATRM-N**  
Male NPT Run Tee  **45**

**ATBM-R**  
Male BSPT Run Tee  **46**

**ATBM-N,-R**  
Male NPT/BSPT  
Branch Tee  **47**

**ATBM-N**  
Male NPT  
Branch Tee  **48**

**ATBM-R**  
Male BSPT  
Branch Tee  **49**

## Tube to Female Pipe

### Female Connectors

**ACF-N**  
Female NPT  
Connector  **50,51**

**ACF-R**  
Female BSPT  
Connector  **52,53**

**9PP-GG**  
Copper Gasket  **54**

**ACF-GG**  
Female Gauge  
Connector  **55**

**ACBF-N**  
Bulkhead  
Female NPT  
Connector  **56**

### Female Elbows

**ALF-N**  
Female NPT  
Elbows  **57**

### Female Run / Branch Tees

**ATRF-N**  
Female NPT Run Tee  **58**

**ATBF-N**  
Female NPT  
Branch Tee  **59**

## Tube Adapters

### Tube Adapter to Tube

**ACP**  
Port Connector  **60**

**ACPR**  
Reducing Port  
Connector  **61**

**AR**  
Port Reducer  **62,63**

**AAB**  
Bulkhead Tube  
Adapter  **64**

**ALA**  
Elbow Tube  
Adapter  **64**

**ATRA**  
Run Tee Tube  
Adapter  **65**

**ATBA**  
Branch Tee Tube  
Adapter  **65**

### Tube Adapter to Male Pipe

**AAM-N**  
Male NPT Tube  
Adapter  **66**

**AAM-R**  
Male BSPT Tube  
Adapter  **67**

**AAM-G**  
Male ISO Parallel Tube  
Adapter  **68**

**AAM-UF**  
Male SAE Tube Adapter  **69**

**AAM-UO**  
Male O-Seal Tube  
Adapter  **69**

**AMAA**  
Male AN Tube Adapter  **70**

### Tube Adapter to Female Pipe

**AAF-N**  
Female NPT Tube Adapter **70,71**

**AAF-R**  
Female BSPT Tube  
Adapter  **71**

**AAF-GZ**  
Female ISO Parallel  
Tube Adapter **72**

**AAF-GG**  
Female Gauge Tube Adapter **72,73**

**AAA**  
AN Adapter  **73**

## Tube to Weld End

**ACSW**  
Tube Socket Weld  
Connector  **74**

**ALSW**  
Tube Socket Weld Elbow  **74**

**ACBW**  
Pipe Butt Weld Connector  **75**

**ALBW**  
Pipe Butt Weld Elbow  **76**

**ABUW**  
Bulkhead Weld Union  **76**

## Tube to Flange

**AF**  
Flange Adapters **77,78**

**AFC**  
Lap Joint Flange  
Connector  **78**

## Engineered Products

**AEU**  
Dielectric Fittings  **79**

**AFU**  
Fusible Plugs  **80**

**AVP**  
Vent Protector  **80**

## Caps, Plugs, Tube Inserts

**AC**  
Tube Cap  **81**

**AP**  
Port Plugs  **82**

**AI**  
Tube Insert  **82**

## Spare Parts

**AFF**  
Front Ferrule  **83**

**AFB**  
Back Ferrule  **83**

**AFS**  
Ferrule Set  **84**

**AFSN**  
Nut-Ferrule Set  **84**

**AN**  
Nut  **85**

**AJN**  
Bulkhead  
Jam Nut  **86**

**APN-UP/GR**  
Positionable  
Lock Nut  **86**

## Tools

**AIG**  
Gap Inspection Gauge  **87**

**ATM**  
Tube Depth Marker  **87**

**APS**  
Preswaging Tool  **88**

**AHP**  
Pre-Swaging Unit  **88**

## Material Standards / Application

M Tube Fittings are supplied in a wide range of materials for extensive applications.

- Shipbuilding
- On Shore Oil & Gas
- Offshore Oil & Gas
- Chemical & Petrochemical
- Refinery
- Analytical Instrumentation
- Power Generation
- Steel Mill
- Alternative Fuel
- Pharmaceutical
- Diesel & Dual Fuel Engine

## Material Standards

D*	Material Grade	ASTM Standards	
		Bar Stock	Forging
SS	Stainless Steel	A479, A276 Type 316/316L JIS G4303 SUS316	A182 F316/F316L JIS G 3214 SUS F316
C	Carbon Steel	A108 JIS G4051 S20C-S53C	A105 JIS G4051 S20C-S53C
B	Brass	B16, B453 C35300 JIS H3250 C3604, C3771	B283 Alloy 37700 JIS H3250 C3771
6MO	6Mo	A276 S31254	A182 Grade F44 S31254
L20	Alloy 20	B473 N08020	B462 N08020
L400	Monel 400	B164 N04400	B564 N04400
L600	Alloy 600	B166 N06600	B564 N06600
L625	Alloy 625	B446 N06625	B564 N06625
L825	Alloy 825	B425 N08825	B564 N08825
C276	Hastelloy C276	B574 N10276	B564 N10276
D	Duplex SAF 2205 TM	A276 S31803 A479 S31803	A182 F51
SD	Super Duplex SAF 2507TM	A479 S32750	A182 F51
TI4	Titanium Gr.4	B348 Gr. 4	B381 F-4
AL	Aluminium	B211 Alloy 2024T6 JIS H4040 A2024, A6061	B247
PE	PTFE	D1710	D3294

D\*: Material Designator

## Stainless Steel Tube Fittings

Over 1 in. / 25mm OD fittings are supplied with stainless steel ferrules coated with PFA. For applications beyond 450 °F (232 °C) silver-plated front ferrule and uncoated back ferrule are supplied.

## Carbon Steel Tube Fittings

Carbon steel fittings are White Zinc Electroplated with Chrome VI free and supplied with stainless steel 316 back ferrule.

## Pre-Lubricated Nuts

Stainless steel nuts are pre-lubricated with silver plating that eliminates thread galling and reduces assembly torque.

## Outstanding Performance

M Tube Fitting provides Outstanding Leak-Tight Performance across applications; Gas, Liquid, Steam in High Pressure, Heavy Vibration, Thermal Stress, and Extreme Impulse application.

- Cold roll M Tube Fitting Port thread provides higher load strength.
- Ferrules are constructed using proven Carpenter™ materials.
- Mechanical properties of ferrules are designed to swage the maximum hardness of tubing.
- Selectively hardened back ferrule only on leading edge provides elasticity, driving front ferrule for full metal surface contact.
- Excellent make & remake performance with outstanding combination of mechanical properties.
- Excellent performance in gas leak tight with outstanding sealing system.
- 4 to 1 safety ratio between working vs. burst pressure.
- Heat code traceable.

## High Pressure Gas Application

To run flow, fluid system is pressurized. Especially a gas needs to be highly compressed to fill smaller tank or container.

Pressure over 500 psig (34.5 bar) is considered high pressure. M Tube Fittings provide gas leak-tight performance based on the working pressure of the tubing selected.

## Tubing For Gas Application

Use heavier wall tubing for gas application.

Heavier wall tubing recommended for gas service is identified in the non-shaded area of the tubing tables beginning on page 8. The thin wall tubes are shaded for identification from heavier wall tubes that are not shaded.

Gases such as steam, air, oxygen, helium, nitrogen, methane, propane, etc have extremely small molecules that can escape through even the most minute leak path.

Heavier wall tubing allows the ferrules to coin out minor defects on tube surface whereas thin wall provides less resistance to ferrule action, resulting in less chance of coining out surface defects.

Defects on tubing surface should be considered leak paths.

## Vacuum Application

Outstanding Sealing System of M Tube Fitting eliminates air-ingress into the tubing system at vacuum conditions. With properly selected tubing, M Tube Fittings perform leak-tight up to the vacuum level of 10<sup>-9</sup> torr.

## Cryogenic Application

Below -100 °F (-37 °C) is considered cryogenic temperature. Stainless Steel M Tube Fittings provide outstanding leak-tight performance up to -328 °F (-200 °C) cryogenic application.

# M Tube Fittings®

## Make and Remake

Outstanding mechanical properties of M Tube Fitting provides excellent make and remake performance.

## Leak-Free

Following M Tube Fitting's Installation Instructions leads to a leak-free tubing system.

## Metric M Tube Fittings



Metric M Tube Fittings are visually identifiable by the stepped shoulders on nut and body. Metric nut and straight body are constructed out of metric hexagonal barstock.

## Cleaning and Surface Protection

Tube fittings are cleaned to remove surface contamination, loose particles, iron particles from machining tools, and oil from cutting fluid. Additional processing takes place to protect tube fittings from corrosion and to improve performance.

Special cleaning in compliance with the requirements of ASTM G93 Level C is optional.

Fitting Body Materials	Additional Processing
Stainless Steel, 6Mo	Passivation
Carbon Steel	White Zinc Electroplating with Chrome VI free
Brass	Acid Cleaning
Alloy 20, Monel 400, Alloy 600, Alloy 625, Alloy 825, C276, Duplex, Super Duplex	Hydrocarbon Film
Titanium Gr.4	Anodizing
Aluminum	Anodizing, Hydrocarbon Film
PTFE	Cleaning

## High Quality Tubing Selection

Purchasing high quality tubing, maintaining the tubing quality on the good quality tubing rack, and proper handling of the tubing are the key to leak-tight tubing system.

## Tubing Surface

Tube surface must be free from defects; scratches, draw mark, and flat spots.

## Tubing Hardness

- Tubing must be fully annealed.
- Tubing must be suitable for flaring and bending.

## Oval

Tube OD being out of roundness may not fit into fitting.

## Welded Tubing

Welded Tube must not have a measurable bead on outside diameter.

## Tubing Wall Thickness

Wall thickness of tubing governs the working pressure of tubing.

M Tube Fittings are designed to use with TUBING WALLS listed on tubing tables beginning on page 8.

Tubing for **gas application** must use those wall thicknesses outside of the shade in the tubing tables.

Wall thickness not listed in the tubing tables is not recommended for use with M Tube Fittings.

## Tube Handling

Tubing must be carefully handled to keep the tubing surface condition as good as they are delivered.

- Do not drag tubing out of tubing racks.
- Do not drag tubing across a rough surface such as cement.

## Tube Cutting

- Select right tube cutter; wrong cutter may result in excessive deformation on tube end.
- Do not cut deep with each turn of cutter.
- Hacksaw blades should have at least 32 teeth per inch.
- Tube ends should be deburred on both OD and ID before use with tube fitting.

## Thread Standards

The table below contains the thread designator and relevant information of entire pipe thread constructed to M Tube Fittings.

D\*: Thread Designator E\*: Equivalent

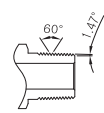
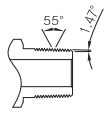
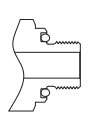
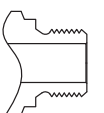
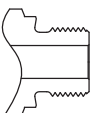
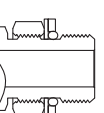
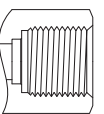
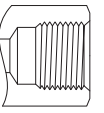
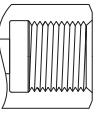
D*	Configuration	Standards	E*
<b>Tapered Pipe Threads</b>			
N		ASME B1.20.1 (NPT)	-
R		ISO 7-1 BS EN 10226 (BSPT) JIS B0203 (PF)	RT
NO		ASME B1.20.1 SAE AS71051 SAE J514  <b>O-Seal NPT Thread Seal by O-ring</b>	OR
<b>Parallel Pipe Threads</b>			
G		ISO 228-1 BS 2779 (BSPP) DIN 3852 (FORM A) JIS B0202 (PF)  <b>Seal by Bonded Gasket or Copper Gasket</b>	RS
GB		ISO 228-1 BS 2779 (BSPP) DIN 3852 (FORM B) JIS B0202 (PF)  <b>Seal by Copper Gasket, Compression against Female flat face.</b>	RP
GR		ISO 228-1 BS 2779 (BSPP) JIS B0202 (PF)  <b>Positionable Seal by O-ring</b>	PR
GG		ISO 228-1, BS 2779 (BSPP) EN837-1, 837-3, JIS B0202 (PF)  <b>Gauge Port Seal by copper gasket at the bottom of GG female port</b>	RG
GZ		ISO 228-1 BS 2779 (BSPP) DIN 3852 (FORM Z) JIS B0202 (PF)  <b>With G &amp; GB Male thread Seal by copper gasket over the flat face of female</b>	RP
GY		ISO 228-1, BS 2779 (BSPP) DIN 3852 (FORM Y) JIS B0202 (PF)  <b>With G &amp; GB male thread Seal by PTFE Gasket at the Bottom of GY port.</b>	RJ

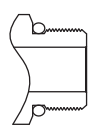
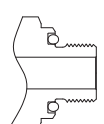
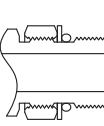
SAE Straight Threads			
UF		ASME B1.1, SAE J514 ISO R725, DIN 3852 (FORM F)  <b>Non-Positionable Seal by O-ring to SAE J1926/1 Straight Thread Boss</b>	SR
UO		ASME B1.1 SAE J514, ISO R725  <b>O-Seal SAE straight thread Seal by O-ring to SAE J1926/1 Straight Thread Boss</b>	OR
UP		ASME B1.1 SAE J514, ISO R725  <b>Positionable Seal by O-ring to SAE J1926/1 Straight Thread Boss</b>	ST

## Pressure Rating

### M Tube Fitting Pressure Rating

M Tube Fitting End is rated to the working pressure of tubing as listed in the tubing tables.

### Threaded / Butt Weld / Socket Weld /O-ring End /AN End Pressure Rating

When fitting is combined with threaded / butt weld / socket weld / O-ring End, the pressure rating of these ends may be the limiting factor on the fitting's pressure rating.

Pressure ratings are based on ASME B31.3 Process Pipe Code at ambient temperature unless otherwise specified.

### Tapered Pipe Thread End – N, and R

Pipe Size in.	Stainless and Carbon Steel				Brass			
	Male		Female		Male		Female	
	psi	bar	psi	bar	psi	bar	psi	bar
<b>S Value</b>	20ksi				10ksi			
1/16	14,000	965	6,600	455	7,400	510	3,300	227
1/8	10,000	689	6,400	441	5,000	345	3,200	220
1/4	8,300	572	6,500	448	4,100	282	3,200	220
3/8	8,000	551	5,200	358	4,000	275	2,600	179
1/2	7,800	537	4,800	331	3,900	269	2,400	165
3/4	7,500	517	4,600	317	3,700	255	2,300	158
1	5,300	365	4,400	303	2,600	179	2,200	152
1-1/4	6,200	427	5,000	345	3,100	214	2,500	172
1-1/2	5,100	351	4,500	310	2,500	172	2,200	152
2	4,000	276	3,900	269	2,000	138	1,900	131

### Parallel Pipe Thread End – G, and GB

Pipe Size, in.	Stainless and Carbon Steel	
	Male	
	psi	bar
<b>S Value</b>	20ksi	
1/8	16000	1103
1/4	12500	861
3/8	12000	827
1/2	11900	820
3/4	8000	551
1	5600	386
1 1/4	5400	372
1 1/2	5100	351

## SAE Straight Thread End – UF, and UP

Nominal SAE Dash Size	SAE Thread Size	Stainless and Carbon Steel			
		Non-Positionable "UF"		Positionable "UP"	
		psi	bar	psi	bar
2	5/16-24	4568	315	4568	315
4	7/16-20			3626	250
6	9/16-18			2900	200
8	3/4-16			2320	160
10	7/8-14	3626	250	2900	200
12	1 1/16-12			2320	160
14	1 3/16-12	2900	200	2320	160
16	1 5/16-12			1813	125
20	1 5/8-12	2320	160	1813	125
24	1 7/8-12			1450	100
32	2 1/2-12				

Pressure ratings are based on SAE J1926/3 at ambient temperature.

## Positionable ISO/BSPP Parallel Thread – GR

ISO/BSPP Male Pipe Size in.	Stainless Steel and Carbon Steel	
	psi	bar
1/8	4568	315
1/4		
3/8		
1/2	2320	160
3/4		
1		

Pressure ratings are at ambient temperature.

## SAE J514 37° Flare AN End

Tube OD		Stainless and Carbon Steel	
		SAE J514, Table 1.	
Metric, mm	in.	psi	bar
2	1/8	5000	344
6	1/4	5000	344
8	5/16	5000	344
10	3/8	4000	275
12	1/2	3000	206
16	5/8	3000	206
20	3/4	2500	172
25	1	2000	137
32	1 1/4	1150	79.2
38	1 1/2	1000	68.9
50	2	1000	68.9

Pressure Ratings are extracted from SAE J514 Standard.

## Pipe Butt Weld End – BW

Nom. Pipe Size	Stainless and Carbon Steel	
	Butt Weld End	
	psi	bar
<b>S Value</b>	20ksi	
1/8	5300	365
1/4	5200	358
3/8	4400	303
1/2	4100	282
3/4	3200	220
1	3100	213
1 1/4	3000	206
1 1/2	2900	199
2	1900	131

Pressure ratings are at ambient temperature.

## Tube Socket Weld Ends - SW

Socket Weld End is rated to the working pressure of tubing connected.

**O Seal Fitting "NO" and "UO" Ends**  
Stainless and Carbon Steel "NO" & "UO" Ends up to 1 in. are rated to 3000 psig (206 bar) at ambient temperature.

## Pressure Equivalents

BAR	Mpa	PSI
1	0.1	14.5
100	10	1450
160	16	2321
210	21	3045
315	31.5	4569
350	35	5075
400	40	5801
413.68	41.36	6000

## Temperature Rating

When combining with O-ring, the temperature rating of the O-ring may be the limiting factor on fitting's temperature rating. Brass and Carbon Steel O-ring fittings are supplied with 70 durometer NBR O-ring; Stainless Steel O-ring fittings are supplied with 90 durometer FKM O-ring.

## O-ring Temperature Ratings

O-ring	Designator	Temperature Rating °F (°C)
NBR	BN	-13 to 230 (-25 to 110)
FKM	VT	-20 to 400 (-28 to 204)
FFKM (Kalrez®)	KZ4	-22 to 600 (-30 to 315)

## Fitting and Tubing Materials

Use of like tubing and fitting material is essential for leak-tight tubing system. Use of unlike material may affect sealing integrity. Copper tubing with brass M Tube Fitting is only exception.



**Table 1. Fractional Seamless Stainless Steel Tubing**

Fully annealed seamless stainless steel tubing ASTM A269 or A213 TP 316/316L, 304/304L or equivalent. Tubing free from scratches, and suitable for bending and flaring. Hardness 90 HRB or less.

Tube OD in	Wall Thickness (in)														
	0.012	0.014	0.016	0.02	0.028	0.035	0.049	0.065	0.083	0.095	0.109	0.12	0.134	0.156	0.188
	Working Pressure (psi)														
1/16	6800	8100	9400	12000											
1/8					8500	10900									
3/16					5400	7000	10200								
1/4					4000	5100	7500	10200							
5/16						4000	5800	8000							
3/8						3300	4800	6500	8600						
1/2						2600	3700	5100	6700						
5/8							2900	4000	5200	6000					
3/4							2400	3300	4200	4900	5800	6400			
7/8							2000	2800	3600	4200	4800	5400	6100		
1								2400	3100	3600	4200	4700	5300	6200	
1 1/4									2400	2800	3300	3600	4100	4900	
1 1/2										2300	2700	3000	3400	4000	4900
2											2000	2200	2500	2900	3600

**Table 2. Metric Seamless Stainless Steel Tubing**

Tube OD in	Wall Thickness (mm)														
	0.6	0.8	1	1.2	1.5	1.8	2	2.2	2.5	2.8	3	3.5	4	4.5	5.0
	Working Pressure (bar)														
2	780	1050													
3	516	710													
4	520	660													
6		330	420	520	670										
8			310	380	490										
10			240	300	380										
12			200	240	310	380	430								
14			180	220	280	340	390	430							
15			170	200	260	320	360	400							
16				190	240	300	330	370							
18				170	210	260	290	320	370						
20				150	190	230	260	290	330	380					
22				130	170	210	230	260	300	340					
25						180	200	230	300	340	320				
28							180	200	230	260	280	330			
30							170	190	210	240	260	310			
32							160	170	200	230	240	290	330		
38								140	170	190	200	240	280	310	
42										170	180	210	250	280	
50											150	180	200	230	260

Allowable working pressures are calculated using S value of 20 000psi (1378 bar) for ASTM A269 tubing at -20 to 100°F (-28 to 37°C) as listed in ASME B31.3 Process Piping Code and ASME B31.1 Power Piping Code.

- Pressure calculations are made with maximum O.D. and minimum wall thickness. No allowance is made for corrosion and erosion. Example: ASTM A 269 Type 316 Tubing, 1/2 in. OD x 0.065 in. WT.  
ASTM A269 standard specifies permissible OD tolerance: +/- 0.005 in. (+/-0.13mm), permissible WT tolerance: +/- 15%  
Allowable working pressure is therefore calculated with maximum OD 0.505 in. and minimum WT 0.0552 in.
- Safety Factor 3.75 to 1, considering specified ultimate tensile strength of 75,000 psi.

**Welded Stainless Steel Tubing**

ASME B31.3 Code requires that for welded tubing, a de-rating factor must be applied for the allowable working pressure. For single welded tubing, multiply working pressure by 0.80, and for double welded tubing, multiply working pressure by 0.85.

**Table 3. Fractional Seamless Carbon Steel Tubing**

Soft annealed seamless cold drawn carbon steel tubing, ASTM A179 or equivalent. Tubing free from scratches, and suitable for bending and flaring. Hardness 72 HRB or less.

Tube OD in	Wall Thickness (in)												
	0.028	0.035	0.049	0.065	0.083	0.095	0.109	0.12	0.134	0.148	0.165	0.18	0.22
Working Pressure (psi)													
1/8	8000	10200											
3/16	5100	6600	9600										
1/4	3700	4800	7000	9600									
5/16		3800	5500	7600									
3/8		3100	4500	6200									
1/2		2300	3300	4500	5900								
5/8		1800	2600	3500	4600	5300							
3/4			2100	2900	3700	4300	5100						
7/8			1800	2400	3200	3700	4300						
1			1500	2100	2700	3200	3700	4100					
1 1/4				1600	2100	2500	2900	3200	3600	4000	4600	5000	
1 1/2					1800	2000	2400	2600	3000	3300	3700	4100	5100
2						1500	1700	1900	2200	2400	2700	3000	3700

**Table 4. Metric Seamless Carbon steel Tubing**

Tube OD mm	Wall Thickness (mm)												
	0.8	1	1.2	1.5	1.8	2	2.2	2.5	2.8	3	3.5	4	4.5
Working Pressure (bar)													
3	670	830											
6	310	400	490	630									
8		290	360	460									
10		230	280	360									
12		190	230	290	360	410	450						
14		160	190	250	300	340	380						
15		150	180	230	280	320	350						
16			170	210	260	290	330	380					
18			150	190	230	260	290	330					
20			130	170	200	230	250	290	330				
22			120	150	180	210	230	260	300				
25					160	180	200	230	260	280			
28						160	180	200	230	250	290		
30						150	160	190	210	230	270		
32						140	150	170	200	210	250	290	
38							130	140	160	180	210	240	280

Allowable working pressures are calculated using S value of 15,700 psi for ASME A179 tubing at -20 to 100°F (-28 to 37°C) as listed in ASME B31.3 Process Piping Code.

- Safety Factor 3 to 1, considering ultimate tensile strength of 47,000 psi.
- To determine working pressure of ASME B31.1 Power Piping Code, multiply the ASME B31.3 rating by 0.85.

**Table 5. Fractional Seamless Copper Tubing**

Soft annealed seamless copper tubing ASTM B75 or equivalent. Also soft annealed seamless copper water tube ASTM B88 Type K or L. Tubing free from scratches, and suitable for bending and flaring. Hardness 60 HRB or less.

Tube OD in	Wall Thickness (in)										
	0.01	0.012	0.028	0.035	0.049	0.065	0.083	0.095	0.109	0.12	0.134
Working Pressure (psi)											
1/8			2700	3600							
3/16			1800	2300	3400						
1/4			1300	1600	2500	3500					
5/16				1300	1900	2700					
3/8				1000	1600	2200					
1/2				800	1100	1600	2100				
5/8					900	1200	1600	1900			
3/4					700	1000	1300	1500	1800		
7/8					600	800	1100	1300	1500		
1					500	700	900	1100	1300	1500	
1 1/8						600	800	1000	1100	1300	1400

**Table 6. Metric Seamless Copper Tubing**

Tube OD mm	Wall Thickness (mm)											
	0.7	0.8	1.0	1.2	1.5	1.6	1.8	2.0	2.2	2.5	2.8	3.0
Working Pressure (bar)												
3	220	250										
4	160	190	240	290								
6		120	150	190	240	260						
8		80	110	130	170	190						
10		70	80	100	130	150	170	190				
12		50	70	80	110	120	130	150				
14			60	70	90	100	110	130	140	170	190	200
16			50	60	80	80	100	110	120	140	160	180
18			40	50	70	70	80	100	110	120	140	150
22			30	40	50	60	70	80	80	100	110	120
25			30	40	50	50	60	70	70	80	100	100
28							50	60	60	70	80	90

Allowable working pressures are calculated using S value of 6000 psi for ASTM B75 and B88 tubing at -20 to 100°F (-28 to 37°C) as listed in ASME B31.3 Process Piping Code and ASME B31.1 Power Piping Code.

- Safety Factor 5 to 1, considering ultimate tensile strength of 30,000 psi.

**Alloy 400 (Monel) Tubing**

Fully annealed seamless Alloy 400 tubing, ASTM B165 or equivalent. Tubing to be free from scratches, and suitable for bending and flaring. Hardness 75HRB or less. OD tolerance not to exceed +/- 0.005 in. or +/- 0.13 mm.

**Table 7. Fractional Seamless Alloy 400 Tubing**

Tube OD in	Wall Thickness (in)							
	0.028	0.035	0.049	0.065	0.083	0.095	0.109	0.12
Working Pressure (psi)								
1/8	7900	10200						
1/4	3700	4800	7000	9600				
3/8		3100	4400	6100				
1/2		2300	3300	4400				
3/4			2200	3000	4000	4600		
1				2200	2900	3400	3900	4300

**Table 8. Metric Seamless Alloy 400 Tubing**

Tube OD mm	Wall Thickness (mm)									
	0.8	1.0	1.2	1.5	1.8	2.0	2.2	2.5	2.8	3.0
Working Pressure (bar)										
6	370	480	590	750						
8		350	430	550						
10		270	330	430						
12		220	270	350						
14		190	230	290	360					
18			170	220	270	310	340			
20				200	240	270	300	350		
25					170	210	240	270	310	330

Allowable working pressures are calculated using S value of 18,700 psi for ASTM B165 tubing at -20 to 100°F (-28 to 37°C) as listed in ASME B31.3 and ASME B31.1.

- Safety Factor 3.7 to 1, considering ultimate tensile strength of 70,000 psi.

## Alloy C276 Tubing

Fully annealed seamless Alloy C276 tubing, ASTM B622 or equivalent. Tubing to be free from scratches, and suitable for bending and flaring. Hardness 100 HRB or less. OD tolerance not to exceed +/- 0.005 in. or +/-0.13 mm.

**Table 9. Metric Seamless Alloy C276 Tubing**

Tube OD in	Tube Wall Thickness (in)					
	0.020	0.028	0.035	0.049	0.065	0.083
	Working Pressure (psig)					
1/8	8,200	12,000	15,300			
3/16	5,300	7,700	9,900	14,400		
1/4		5,600	7,200	10,600	14,400	
5/16			5,700	8,200	11,300	
3/8			4,700	6,700	9,200	
1/2			3,400	4,900	6,700	8,800

**Table 10. Metric Seamless Alloy C276 Tubing**

Tube OD mm	Tube Wall Thickness (mm)					
	0.8	1.0	1.2	1.5	1.8	2.0
	Working Pressure (bar)					
6	450	600	760	1,000		
8		440	550	730		
10		340	430	570		
12		280	350	460	580	660

Allowable working pressures are calculated using S value of 27,300 psi for ASTM B622 tubing at -20 to 100°F (-28 to 37°C) as listed in ASME B31.3 and ASME B31.1.

- Safety Factor 3.6 to 1, considering ultimate tensile strength of 100,000 psi.

## Alloy 825 Tubing

Fully annealed seamless Alloy 825 tubing, ASTM B423 or equivalent. Tubing to be free from scratches, and suitable for bending and flaring. Hardness not to exceed 201 HV.

**Table 11. Fractional Seamless Alloy 825 Tubing**

Tube OD in	Tube Wall Thickness, in.					
	0.020	0.028	0.035	0.049	0.065	0.083
	Working Pressure (psig)					
1/8	7,300	10,700	13,700			
3/16	4,700	6,800	8,800	12,800		
1/4		5,000	6,400	9,300	12,700	
5/16			5,000	7,300	10,000	
3/8			4,100	5,900	8,200	
1/2			3,000	4,300	5,900	7,800

**Table 12. Metric Seamless Alloy 825 Tubing**

Tube OD mm	Tube Wall Thickness, mm					
	0.8	1.0	1.2	1.5	1.8	2.0
	Working Pressure (bar)					
6	460	600	730	930		
8		430	530	680		
10		340	410	530		
12		280	340	430	530	600

Allowable working pressures are calculated using S value of 23,300 psi for ASTM B423 tubing at -20 to 100°F (-28 to 37°C) as listed in ASME B31.3 and ASME B31.1.

- Safety Factor 3.65 to 1, considering ultimate tensile strength of 85,000 psi.

## Table 13. Fractional Seamless Super Duplex Tubing

Fully annealed seamless super duplex tubing, ASTM A789 S32750 or equivalent. Tubing to be free from scratches, and suitable for bending and flaring. Hardness 32 HRC or less.

Tube OD in	Tube Wall Thickness, in.				
	0.028	0.035	0.049	0.065	0.083
	Working Pressure (psig)				
1/4	7,800	9,900	14,500		
3/8		6,400	9,200	12,700	
1/2		4,700	6,800	9,200	12,100

- Allowable working pressures are calculated using S value of 38,700 psi for ASTM A789 tubing at -20 to 100°F (-28 to 37°C) as listed in ASME B31.3.
- Safety Factor is 3 to 1, considering ultimate tensile strength of 116,000 psi.

**Alloy 625 Tubing**

Fully annealed seamless Alloy 625 tubing, ASTM B444 Grade 2 or equivalent. Tubing to be free from scratches, and suitable for bending and flaring. Hardness not to exceed 25 HRC.

**Table 14. Fractional Seamless Alloy 625 Tubing**

Tube OD in.	Tube Wall Thickness, in.					
	0.020	0.028	0.035	0.049	0.065	0.083
	Working Pressure (psig)					
1/8	8,400	12,200	15,600			
3/16	5,400	7,800	10,100	14,600		
1/4		5,700	7,300	10,600	14,600	
5/16			5,700	8,300	11,400	
3/8			4,700	6,800	9,300	
1/2			3,400	5,000	6,800	8,900

**Table 15. Metric Seamless Alloy 625 Tubing**

Tube OD mm	Tube Wall Thickness, mm					
	0.8	1.0	1.2	1.5	1.8	2.0
	Working Pressure (psig)					
6	473	614	754	967		
8		447	547	707		
10		347	427	547		
12		287	353	447	547	620

Allowable working pressures are calculated using S value of 26,700 psi for ASTM B444 Grade 2 tubing at -20 to 100°F (-28 to 37°C) as listed in ASME B31.1.

- Safety Factor 3.75 to 1, considering ultimate tensile strength of 100,000 psi.

**Alloy 600 Tubing**

Fully annealed seamless Alloy 600 tubing, ASTM B167 or equivalent. Tubing to be free from scratches, and suitable for bending and flaring. Hardness 92 HRB or less. OD tolerance not to exceed +/- 0.005 in. and +/- 0.13mm.

**Table 16. Fractional Seamless Alloy 600 Tubing**

Tube OD in.	Tube Wall Thickness, in.			
	0.028	0.035	0.049	0.065
	Working Pressure (psig)			
1/4	4,000	5,100	7,500	10,200
3/8		3,300	4,800	6,500
1/2		2,400	3,500	4,700

**Table 17. Metric Seamless Alloy 600 Tubing**

Tube OD mm	Tube Wall Thickness mm			
	0.8	1	1.2	1.5
	Working Pressure (bar)			
6	330	430	520	670
10		240	300	380
12		200	240	310

Allowable working pressures are calculated using S value of 20,000 psi for ASTM B167 tubing at ambient temperature as listed in ASME B31.3 and ASME B31.1.

- Safety Factor 5 to 1, considering ultimate tensile strength of 80,000 psi.

**Alloy 20 Tubing**

Fully annealed seamless Alloy 20 tubing ASTM B729, welded tubing ASTM B468 or equivalent. Tubing to be free from scratches, and suitable for bending and flaring. Hardness 95 HRB or less. OD Tolerance not to exceed +/-0.005 in. and +/-0.13 mm.

**Table 18. Fractional Seamless Alloy 20 Tubing**

Tube OD in.	Tube Wall Thickness, in.					
	0.020	0.028	0.035	0.049	0.065	0.083
	Working Pressure, psig					
1/8	6800	9900	12700			
3/16	4400	6300	8200	11900		
1/4		4700	5900	8700	11900	
5/16			4700	6800	9400	
3/8			3800	5500	7600	
1/2			2800	4100	5500	7300

**Table 19. Metric Seamless Alloy 20 Tubing**

Tube OD mm	Tube Wall Thickness, mm					
	0.8	1.0	1.2	1.5	1.8	2.0
	Working Pressure, bar					
6	390	500	610	780		
8		360	440	570		
10		280	350	440		
12		230	280	360	450	500

Allowable working pressures are calculated using S value of 23,300 psi for ASTM B729 tubing at ambient temperature as listed in ASME B31.3.

- To determine working pressure of ASME B31.1, multiply the ASME B31.3 rating by 0.98.
- Safety Factor 3.4 to 1, considering ultimate tensile strength of 80,000 psi.

## Titanium Grade 2 Tubing

Fully annealed seamless and welded Titanium Grade 2 tubing, ASTM B338 or equivalent. Tubing to be free from scratches, and suitable for bending. OD tolerances not to exceed +/- 0.005 in. or +/-0.13 mm.

**Table 20. Fractional Seamless Tubing**

Tube OD in.	Tube Wall Thickness, in.			
	0.028	0.035	0.049	0.065
Working Pressure, psig				
1/4	3000	3900	5700	7800
3/8		2500	3600	5000
1/2		1800	2600	3600

**Table 21. Metric Seamless Tubing**

Tube OD mm	Tube Wall Thickness, mm			
	0.8	1.0	1.2	1.5
Working Pressure, bar				
6	330	430	520	670
10		240	300	380
12		200	240	310

Allowable working pressures are calculated using S value of 14,300 psi for ASTM B338 tubing at -20 to 10°F (-28 to 37°C) as listed in ASME B31.1.

- Safety Factor 2.8 to 1, considering ultimate tensile strength of 40,000 psi.

## Aluminum Seamless Tubing

High quality aluminum alloy seamless tubing, ASTM B210 Grade 6061-T6 or equivalent. Tubing to be free from scratches.

**Table 22. Fractional Aluminum Seamless Tubing**

Tube OD in.	Tube Wall Thickness, in.				
	0.035	0.049	0.065	0.083	0.095
Working Pressure, psig					
1/8	8600				
3/16	5600	8000			
1/4	4000	5900			
5/16	3100	4600			
3/8	2600	3700			
1/2	1900	2700	3700		
5/8	1500	2100	2900		
3/4		1700	2400	3200	
1		1300	1700	2300	2700

**Table 23. Metric Aluminum Seamless Tubing**

Tube OD mm	Tube Wall Thickness, mm						
	1.0	1.2	1.5	1.8	2.0	2.2	2.5
Working Pressure, bar							
6	340	420					
8	250	300					
10	190	240					
12	160	190	250	310			
14	130	160	210	260			
15	120	150	190	240			
16	120	140	180	220			
18		120	160	190	220		
20			140	170	190		
22			130	150	170	190	
25			110	130	150	170	190

Allowable working pressures are calculated using S value of 14,000 psi for ASTM B210 Grade 6061-T6 tubing at -20 to 100°F (-28 to 37°C) as listed in ASME 31.3.

- Safety Factor 3 to 1, considering ultimate tensile strength of 42,000 psi.
- To determine working pressure of ASME B31.1 Power Piping Code, multiply the ASME B31.3 rating by 0.85.

## Elevated Temperature De-rating Factors

M Tube Fitting End is rated to the working pressure of tubing as listed in the tubing tables. The working pressure is de-rated as the temperature is elevated.

To determine working pressure at an elevated temperature, multiply the working pressure listed in table 1 through 23 by the applicable factor shown in table 24.

### Example

1. SS316 seamless tubing 1/2 in. OD x 0.065 in. wall.
2. The working pressure at -20 to 100 °F (-28 to 37 °C) is 5100 psig as listed in table 1.
3. To determine working pressure at 1200 °F (649 °C), multiply the 5100 psig by the factor 0.37 from the table 24.  
5100 psig x 0.37 = 1887 psig

**Table 24. Elevated Temperature De-rating Factors**

ASTM Standard		A269	B75	A179	B165	B622	B423	B444	B167	A789	B729	B338	B210
Temperature		SS316	Copper	Carbon Steel	Alloy 400	C276	Alloy 825	Alloy 625	Alloy 600	Super Duplex	Alloy 20	Titanium Gr.2	Aluminum
F°	C°												
100	38	1	1	1	1	1	1	1	1	1	1	1	1
200	93	1	0.80	0.96	0.88	1	1	0.92	1	1	0.86	0.88	1
300	149	1	0.78	0.90	0.82	1	1	0.88	1	0.86	0.85	0.72	1
400	204	0.97	0.50	0.86	0.79	1	1	0.85	1	0.82	0.83	0.61	0.94
500	260	0.9	0.13	0.82	0.79	0.99	1	0.81	1	0.81	0.83	0.53	0.81
600	316	0.85		0.77	0.79	0.93	1	0.79	1	0.81	0.83	0.45	0.56
650	343	0.84		0.75	0.79	0.90	1	0.78	1		0.82		0.40
700	371	0.82		0.73	0.79	0.88	1	0.77	1		0.82		
750	399	0.81		0.68	0.78	0.86	1	0.76	1		0.82		
800	427	0.80		0.59	0.76	0.84	0.99	0.75	1		0.82		
850	454	0.79		0.50	0.59	0.83	0.98	0.74	0.98				
900	482	0.78		0.41	0.43	0.82	0.98	0.73	0.80				
950	510	0.77		0.29		0.81	0.97	0.73	0.53				
1000	538	0.77		0.16		0.80	0.96	0.72	0.35				
1050	566	0.73		0.10		0.68		0.72	0.23				
1100	593	0.62		0.06		0.55		0.72	0.15				
1150	621	0.49				0.45		0.72	0.11				
1200	649	0.37				0.36		0.72	0.10				
1250	677	0.28				0.29							

**Ordering Information**

**Tube OD Designator**

Fractional OD	1/16	1/8	3/16	1/4	5/16	3/8	1/2	5/8	3/4	7/8	1	1 1/4	1 1/2	2
Designator	1	2	3	4	5	6	8	10	12	14	16	20	24	32
Metric OD	2mm	3mm	4mm	6mm	8mm	10mm	12mm	16mm	18mm	22mm	25mm	32mm	38mm	50mm
Designator	2M	3M	4M	6M	8M	10M	12M	16M	18M	22M	25M	32M	38M	50M

**Pipe Thread Size Designator**

Nominal Pipe Size, in.	1/16	1/8	1/4	3/8	1/2	3/4	1	1 1/4	1 1/2	2
Size Designator	1	2	4	6	8	12	16	20	24	32
N	1N	2N	4N	6N	8N	12N	16N	20N	24N	32N
R	1R	2R	4R	6R	8R	12R	16R	20R	24R	32R
G	-	2G	4G	6G	8G	12G	16G	20G	24G	32G

**Material Designators**

Material Grade	Designators	
	Component	Complete Assembly
Stainless Steel 316/316L	SS	SSA
Carbon Steel	C	CA
Brass	B	BA
6Mo	6MO	6MOA
Alloy 20	L20	L20A
Monel 400	L400	L400A
Alloy 600	L600	L600A
Alloy 625	L625	L625A
Alloy 825	L825	L825A
Hastelloy	C276	C276A
Duplex	D	DA
Super Duplex	SD	SDA
Titanium Gr.4	TI4	TI4A
Aluminium	AL	ALA
PTFE	PE	PEA

To order, select a part number and suffix an applicable material designator to the part number.

- To order complete assembly fitting, apply the material designator of complete assembly. Example: AU-8-**SSA**
- To order component only, apply the material designator of component. Examples: Stainless steel Nut 1/2 in. OD : AN-8-**SS**  
Stainless steel Front Ferrule 1/2 in. OD: AFF-8-**SS**

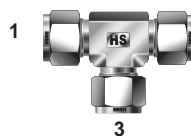

Tee part number is described by first the run (1 and 2) and then the branch (3).

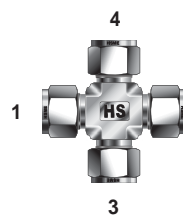

Cross part number is described by first the run (1 and 2) and then the branch (3 and 4).

## Union AU

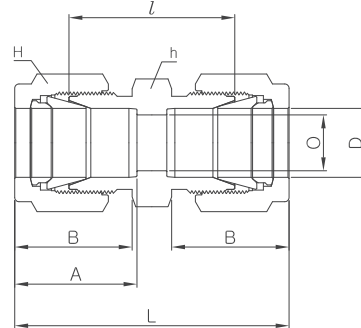
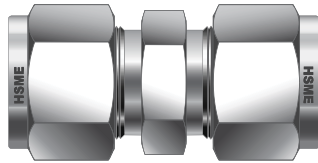

Connects fractional tube

Part No.	Tube O.D. D		O Min.	Width across flat				A	B	/	L
	in	mm		h		H					
				in	mm	in	mm				
AU-1	1/16	1.59	1.27	5/16	7.93	5/16	7.93	8.63	10.92	17.50	25.15
AU-2	1/8	3.17	2.28	7/16	11.11	7/16	11.11	12.70	15.24	22.35	35.56
AU-3	3/16	4.76	3.04	7/16	11.11	1/2	12.70	13.71	16.00	24.13	37.33
AU-4	1/4	6.35	4.82	1/2	12.70	9/16	14.28	15.24	17.78	26.16	40.89
AU-5	5/16	7.93	6.35	9/16	14.28	5/8	15.87	16.25	18.54	28.19	42.92
AU-6	3/8	9.52	7.11	5/8	15.87	11/16	17.46	16.76	19.30	30.22	44.95
AU-8	1/2	12.70	10.41	13/16	20.64	7/8	22.22	22.86	21.84	30.98	51.30
AU-10	5/8	15.87	12.70	15/16	23.81	1	25.40	24.38	21.84	31.75	52.07
AU-12	3/4	19.05	15.74	1-1/16	26.98	1-1/8	28.58	24.38	21.84	33.27	53.59
AU-14	7/8	22.22	18.28	1-3/16	30.16	1-1/4	31.75	25.90	21.84	35.05	55.37
AU-16	1	25.40	22.35	1-3/8	34.92	1-1/2	38.10	31.24	26.41	40.38	64.77
AU-20	1-1/4	31.75	27.68	1-3/4	44.45	1-7/8	47.63	41.14	38.86	48.00	92.20
AU-24	1-1/2	38.10	34.03	2-1/8	53.97	2-1/4	57.15	50.03	45.21	53.60	107.95
AU-32	2	50.80	45.97	2-3/4	69.85	3	76.20	67.56	62.73	74.70	149.35

Connects metric tube

Part No.	Tube O.D. D	O Min.	Width across flat		A	B	/	L
			h	H				
AU-2M	2	1.7	12	12	12.9	15.3	22.4	35.6
AU-3M	3	2.4	12	12	12.9	15.3	22.1	35.3
AU-4M	4	2.4	12	12	13.7	16.1	24.1	37.3
AU-6M	6	4.8	14	14	15.3	17.7	26.2	41.0
AU-8M	8	6.4	15	16	16.2	18.6	28.2	43.2
AU-10M	10	7.9	18	19	17.2	19.5	31.0	46.2
AU-12M	12	9.5	22	22	22.8	22.0	31.0	51.2
AU-15M	15	11.9	24	25	24.4	22.0	31.8	52.0
AU-16M	16	12.7	24	25	24.4	22.0	31.8	52.0
AU-18M	18	15.1	27	30	24.4	22.0	33.3	53.5
AU-20M	20	15.9	30	32	26.0	22.0	34.8	55.0
AU-22M	22	18.3	30	32	26.0	22.0	34.8	55.0
AU-25M	25	21.8	35	38	31.3	26.5	40.4	65.0
AU-28M	28	21.8	41	46	36.6	36.6	43.4	85.0
AU-32M	32	28.6	46	50	42.0	41.6	51.3	97.3
AU-38M	38	33.7	55	60	49.4	47.9	58.4	113.6
AU-42M	42	36.8	60	65	49.3	47.8	58.4	113.4
AU-50M	50	45.2	70	76	65.0	60.2	74.7	146.0





## Bulkhead Union AUB

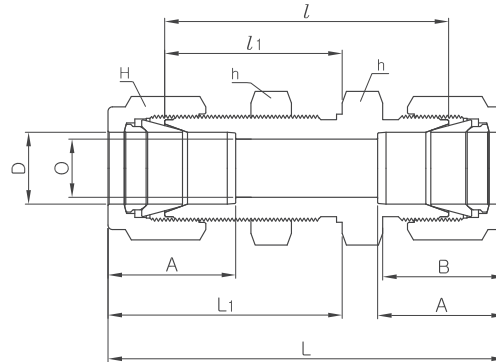
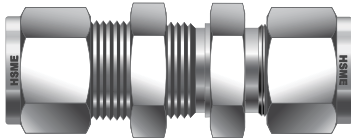

Connects fractional tube

Part No.	Tube O.D. D		O Min.	Width across flat				A	B	/	/1	L	L1	Panel Hole Drill Size	Panel Max Thickness
	in	mm		h		H									
				in	mm	in	mm								
AUB-1	1/16	1.59	1.27	5/16	7.93	5/16	7.93	8.63	10.92	23.87	13.46	31.50	17.27	5.16	3.05
AUB-2	1/8	3.17	2.28	1/2	12.70	7/16	11.11	12.70	15.24	38.10	24.63	51.30	31.24	8.33	12.70
AUB-3	3/16	4.76	3.04	9/16	14.28	1/2	12.70	13.71	16.00	40.38	25.40	53.59	32.00	9.92	12.70
AUB-4	1/4	6.35	4.82	5/8	15.87	9/16	14.28	15.24	17.78	42.92	26.16	57.65	33.52	11.50	10.16
AUB-5	5/16	7.93	6.35	11/16	17.46	5/8	15.87	16.25	18.54	45.97	28.44	60.70	35.81	13.09	11.17
AUB-6	3/8	9.52	7.11	3/4	19.05	11/16	17.46	16.76	19.30	47.49	29.46	62.23	36.83	14.68	11.17
AUB-8	1/2	12.70	10.41	15/16	23.81	7/8	22.22	22.86	21.84	50.80	31.75	71.12	41.91	19.44	12.70
AUB-10	5/8	15.87	12.70	1-1/16	26.98	1	25.40	24.38	21.84	52.32	32.51	72.64	42.67	22.62	12.70
AUB-12	3/4	19.05	15.74	1-3/16	30.16	1-1/8	28.58	24.38	21.84	58.67	37.33	78.99	47.49	25.79	16.76
AUB-14	7/8	22.22	18.28	1-3/8	34.92	1-1/4	31.75	25.90	21.84	64.26	42.92	84.58	53.08	28.97	19.05
AUB-16	1	25.40	22.35	1-5/8	41.27	1-1/2	38.10	31.24	26.41	71.37	45.21	95.75	57.40	33.73	19.05
AUB-20	1-1/4	31.75	27.68	1-7/8	47.63	1-7/8	47.63	41.14	38.86	78.99	47.75	123.19	69.85	41.67	19.05
AUB-24	1-1/2	38.10	34.03	2-1/4	57.15	2-1/4	57.15	50.03	45.21	84.83	49.27	139.19	76.45	49.61	19.05
AUB-32	2	50.80	45.97	2-3/4	69.85	3	76.20	67.56	62.73	105.66	56.38	180.34	93.72	57.94	19.05

Connects metric tube

Part No.	Tube O.D. D	O Min	Width across flat		A	B	/	/1	L	L1	Panel Hole Drill Size	Panel Max Thickness
			h	H								
AUB-3M	3	2.4	14.0	12	12.9	15.3	38.1	24.6	51.3	31.2	8.3	12.7
AUB-4M	4	2.4	14.0	12	13.7	16.1	40.4	25.4	53.6	32.0	9.9	12.7
AUB-6M	6	4.8	16.0	14	15.3	17.7	42.9	26.2	57.7	33.6	11.5	10.2
AUB-8M	8	6.4	18.0	16	16.2	18.6	46.0	28.6	61.0	36.1	13.1	11.2
AUB-10M	10	7.9	22.0	19	17.2	19.5	48.5	29.4	63.7	37.0	16.2	11.2
AUB-12M	12	9.5	24.0	22	22.8	22.0	50.8	31.8	71.0	41.9	19.5	12.7
AUB-15M	15	11.9	27.0	25	24.4	22.0	52.3	32.5	72.5	42.6	22.8	12.7
AUB-16M	16	12.7	27.0	25	24.4	22.0	52.3	32.5	72.5	42.6	22.8	12.7
AUB-18M	18	15.1	30.0	30	24.4	22.0	58.7	37.3	78.9	47.4	26.0	16.8
AUB-20M	20	15.9	35.0	32	26.0	22.0	64.3	42.9	84.5	53.0	29.0	17.0
AUB-22M	22	18.3	35.0	32	26.0	22.0	64.3	42.9	84.5	53.0	29.0	19.1
AUB-25M	25	21.8	41.3	38	31.3	26.5	71.4	45.2	95.9	57.5	33.7	19.1
AUB-32M	32	28.6	50.0	50	42.0	41.6	82.3	49.5	128.3	72.5	42.5	19.0
AUB-38M	38	33.7	60.0	60	49.4	47.9	89.4	51.5	144.6	79.1	50.5	19.0

## Bulkhead Retainer ABR

Keeping the bulkhead retainer and jam nut tightened over panel, bulkhead retainer acts as a backup wrench when tube ports are pulled up.

"U" drive screw is not supplied.

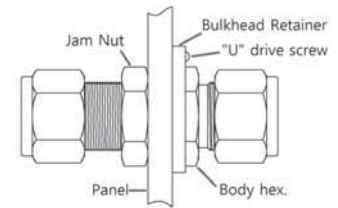
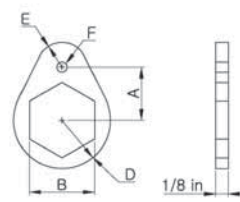

Connects fractional tube

Part No.	Tube O.D. D		A	B	D	E	F	"U" Drive Screw	Drill Number	Drill Hole Dia
	in	mm								
ABR-1-SS	1/16	-	9.52	7.94	7.94	3.97	3.97	#6-3/8	31	3.05
ABR-2-SS	1/8	-	12.7	12.7	10.31	5.55	3.97	#6-3/8	31	3.05
ABR-3-SS	3/16	3M,4M	14.28	14.28	11.90	6.35	3.97	#6-3/8	31	3.05
ABR-4-SS	1/4	6M	15.87	15.87	12.7	7.14	3.97	#6-3/8	31	3.05
ABR-5-SS	5/16	-	17.46	17.46	14.28	7.94	3.97	#6-3/8	31	3.05
ABR-8M-SS	-	8M	17.46	18.0	14.28	7.94	3.97	#6-3/8	31	3.05
ABR-6-SS	3/8	-	19.05	19.05	15.87	8.73	3.97	#6-3/8	31	3.05
ABR-10M-SS	-	10M	23.81	22.0	19.05	10.31	5.55	#10-1/2	27	3.66
ABR-8-SS	1/2	12M	23.81	23.81	19.05	10.31	5.55	#10-1/2	27	3.66
ABR-10-SS	5/8	15M,16M	25.4	26.98	20.64	10.31	5.55	#10-1/2	27	3.66
ABR-12-SS	3/4	18M	26.98	30.16	23.02	11.90	5.55	#10-1/2	27	3.66
ABR-14-SS	7/8	-	28.57	33.33	26.19	13.49	5.55	#10-1/2	27	3.66
ABR-16-SS	1	-	32.54	41.27	29.37	14.28	5.55	#10-1/2	27	3.66

## Bulkhead Elbow Union ABL

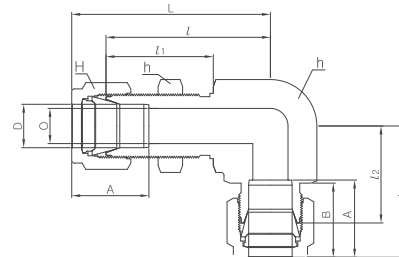
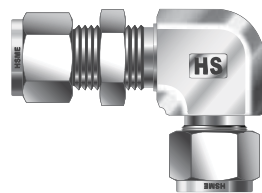

Connects fractional tube

Part No.	Tube O.D. D		O Min.	Width across flat				A	B	I	I <sub>1</sub>	L	L <sub>1</sub>	Panel Hole Drill size	Panel Max Thick ness
	in	mm		h	mm	H	mm								
ABL-4	1/4	6.35	4.82	5/8	15.87	9/16	14.28	15.24	17.78	36.5	20.6	48.01	32.11	11.50	10.16
ABL-6	3/8	9.52	7.11	3/4	19.05	11/16	17.46	16.76	19.30	43.5	25.9	50.82	33.22	14.68	11.17
ABL-8	1/2	12.70	10.41	15/16	23.81	7/8	22.22	22.86	21.84	48.7	28.7	58.84	38.84	19.44	12.70
ABL-12	3/4	19.05	15.74	1-3/16	30.16	1-1/8	28.58	24.38	21.84	60.0	34.5	69.88	44.38	25.79	16.76

Connects metric tube

Part No.	Tube O.D.	O Min.	Width across flat			A	B	I	I <sub>1</sub>	L	L <sub>1</sub>	Panel Hole Drill size	Panel Max Thickness
			h	h <sub>1</sub>	H								
ABL-6M	6	4.8	15.8	14.2	14.0	15.3	17.7	36.5	20.6	43.9	30.0	11.5	10.2
ABL-8M	8	6.4	17.4	17.4	16.0	18.6	46.0	40.9	23.2	48.4	30.7	13.1	11.2
ABL-10M	10	7.9	22.0	22.0	19.0	19.5	48.5	44.5	26.9	52.1	34.5	16.2	11.2
ABL-12M	12	9.5	23.8	23.8	22.0	22.0	50.8	46.9	26.9	57.0	37.0	19.5	12.7
ABL-16M	16	13.5	27.0	27.0	25.0	22.0	52.3	53.5	34.1	63.7	44.5	22.8	12.7
ABL-20M	20	15.9	35.0	35.0	32.0	26.0	22.0	68.4	39.0	78.2	48.7	29.0	17.0
ABL-25M	25	21.8	41.0	41.0	38.0	31.3	26.5	74.2	46.1	86.5	58.4	33.7	19.1

# M Tube Fittings®

## AN Union AUA

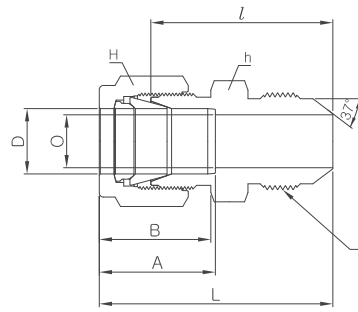
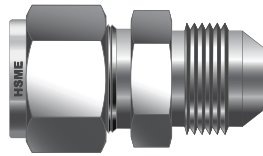

Connects fractional tube to AN flare tube

Part No.	Tube O.D. D		AN Tube Flare Size		Straight Thread T(U)	O Min	Width across flat				A	B	/	L
	in	mm	in	mm			h		H					
							in	mm	in	mm				
AUA 1-2	1/16	1.59	1/8	3.17	5/16-24	1.27	7/16	11.11	5/16	7.93	8.63	10.92	23.36	27.17
AUA 2-2	1/8	3.17	1/8	3.17	5/16-24	1.52	7/16	11.11	7/16	11.11	12.70	15.24	24.89	31.49
AUA 2-4	1/8	3.17	1/4	6.35	7/16-20	2.28	1/2	12.70	7/16	11.11	12.70	15.24	28.44	35.05
AUA 4-4	1/4	6.35	1/4	6.35	7/16-20	4.31	1/2	12.70	9/16	14.28	15.24	17.78	30.22	37.59
AUA 5-5	5/16	7.93	5/16	7.93	1/2-20	5.84	9/16	14.28	5/8	15.87	16.25	18.54	30.98	38.35
AUA 6-4	3/8	9.52	1/4	6.35	7/16-20	4.31	5/8	15.87	11/16	17.46	16.76	19.30	32.25	39.62
AUA 6-6	3/8	9.52	3/8	9.52	9/16-18	7.11	5/8	15.87	11/16	17.46	16.76	19.30	32.25	39.62
AUA 8-8	1/2	12.70	1/2	12.70	3/4-16	9.90	13/16	20.64	7/8	22.22	22.86	21.84	35.81	45.97
AUA 12-12	3/4	19.05	3/4	19.05	1-1/16-12	15.49	1-1/8	28.58	1-1/8	28.58	24.38	21.84	43.18	53.34
AUA 16-16	1	25.40	1	25.40	1-5/16-12	21.33	1-3/8	34.92	1-1/2	38.10	31.24	26.41	49.27	61.46
AUA 20-20	1-1/4	31.75	1-1/4	31.75	1-5/8-12	27.68	1-3/4	44.45	1-7/8	47.63	41.14	38.86	55.46	77.56
AUA 24-24	1-1/2	38.10	1-1/2	38.10	1-7/8-12	34.03	2-1/8	53.97	2-1/4	57.15	50.03	45.21	63.07	90.25
AUA 32-32	2	50.80	2	50.80	2-1/2-12	45.97	2-3/4	69.85	3	76.20	67.56	62.73	83.24	120.57

37° Flare AN End is designed to SAE J514 and ISO 8434-2 standards.  
**AN** is derived from **A**ir Force and **N**avy 37° flare fitting standards.  
 On **AN** port, you can build up a fluid power tubing system.  
 Refer to H Series JIC Tube Fitting Catalog.

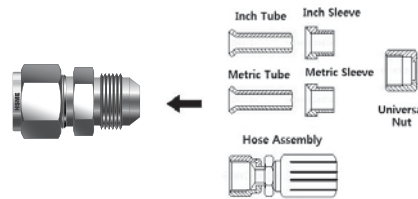

## AN Bulkhead Union AUBA

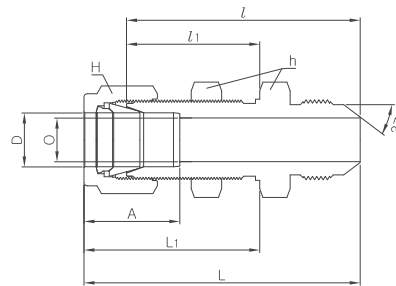
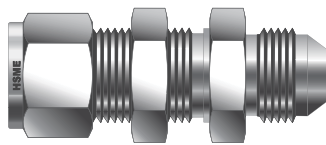

Connects fractional tube to AN flare tube

Part No.	Tube O.D. D		AN Tube Flare Size		Straight Thread T(U)	O Min.	Width across flat				A	/	/1	L	L1	Panel Hole Drill Size	Panel Max Thickness
	in	mm	in	mm			h		H								
							in	mm	in	mm							
AUBA 2-2	1/8	3.17	1/8	3.17	5/16-24	1.77	1/2	12.70	7/16	11.11	13.71	40.85	24.63	47.45	31.23	8.33	12.70
AUBA 4-4	1/4	6.35	1/4	6.35	7/16-20	4.31	5/8	15.87	9/16	14.28	15.24	46.48	26.16	53.84	33.52	11.50	10.16
AUBA 6-6	3/8	9.52	3/8	9.52	9/16-18	7.11	3/4	19.05	11/16	17.46	16.76	49.78	29.46	57.15	36.83	14.68	11.17
AUBA 8-8	1/2	12.70	1/2	12.70	3/4-16	9.90	5/16	23.81	7/8	22.22	22.86	55.62	31.75	65.78	41.91	19.44	12.70
AUBA 12-12	3/4	19.05	3/4	19.05	1-1/16-12	15.49	1-3/16	30.16	1-1/8	28.58	24.38	68.83	37.33	78.99	47.49	25.79	16.76
AUBA 16-16	1	25.40	1	25.40	1-5/16-12	21.33	1-5/8	41.27	1-1/2	38.10	31.24	80.26	45.21	92.45	57.40	33.73	19.05
AUBA 20-20	1-1/4	31.75	1-1/4	31.75	1-5/8-12	27.68	1-7/8	47.63	1-7/8	47.63	41.14	86.37	47.75	108.47	69.85	41.67	19.05
AUBA 24-24	1-1/2	38.10	1-1/2	38.10	1-7/8-12	34.03	2-1/4	57.15	2-1/4	57.15	50.03	94.33	49.27	121.51	76.45	49.61	19.05
AUBA 32-32	2	50.80	2	50.80	2-1/2-12	45.97	2-3/4	69.85	3	76.20	67.56	114.29	56.38	151.62	93.71	16.27	19.05

• Union Elbow  
**AL**

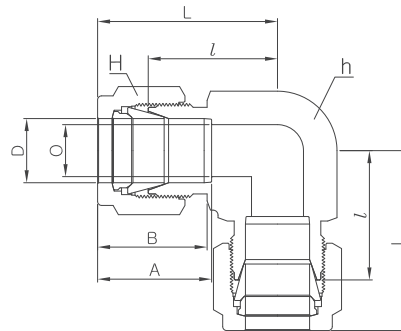

Connects fractional tube

Part No.	Tube O.D. D		O Min	Width across flat				A	B	/	L
	in	mm		h		H					
				in	mm	in	mm				
AL-1	1/16	1.59	1.27	3/8	9.52	5/16	7.93	8.63	10.92	14.00	17.88
AL-2	1/8	3.17	2.28	3/8	9.52	7/16	11.11	12.70	15.24	15.74	22.35
AL-3	3/16	4.76	3.04	1/2	12.70	1/2	12.70	13.71	16.00	17.78	24.38
AL-4	1/4	6.35	4.82	1/2	12.70	9/16	14.28	15.24	17.78	19.55	26.92
AL-5	5/16	7.93	6.35	9/16	14.28	5/8	15.87	16.25	18.54	21.33	28.70
AL-6	3/8	9.52	7.11	5/8	15.87	11/16	17.46	16.76	19.30	23.11	30.48
AL-8	1/2	12.70	10.41	13/16	20.64	7/8	22.22	22.86	21.84	25.90	36.06
AL-10	5/8	15.87	12.70	15/16	23.81	1	25.40	24.38	21.84	28.70	38.80
AL-12	3/4	19.05	15.74	1-1/16	26.98	1-1/8	28.58	24.38	21.84	29.71	39.87
AL-14	7/8	22.22	18.28	1-3/8	34.92	1-1/4	31.75	25.90	21.84	34.54	44.70
AL-16	1	25.40	22.35	1-3/8	34.92	1-1/2	38.10	31.24	26.41	36.83	49.02
AL-20	1-1/4	31.75	27.68	1-11/16	42.86	1-7/8	47.63	41.14	38.86	44.50	66.54
AL-24	1-1/2	38.10	34.03	2	50.80	2-1/4	57.15	50.03	45.21	50.80	77.97
AL-32	2	50.80	45.97	2-3/4	69.85	3	76.20	67.56	62.73	69.80	107.18

Connects metric tube

Part No.	Tube O.D. D	O Min	Width across flat		A	B	/	L
			h	H				
AL-2M	2	1.7	9.5	12	12.9	15.3	15.7	22.3
AL-3M	3	2.4	9.5	12	12.9	15.3	15.7	22.3
AL-4M	4	2.4	12.7	12	13.7	16.4	18.8	25.4
AL-6M	6	4.8	12.7	14	15.3	17.7	19.6	27.0
AL-8M	8	6.4	14.3	16	16.2	18.6	21.3	28.8
AL-10M	10	7.9	17.5	19	17.2	19.5	23.9	31.5
AL-12M	12	9.5	20.6	22	22.8	22.0	25.9	36.0
AL-15M	15	11.9	25.4	25	24.4	22.0	28.7	38.8
AL-16M	16	12.7	25.4	25	24.4	22.0	28.7	38.8
AL-18M	18	15.1	27.0	30	24.4	22.0	29.7	39.8
AL-20M	20	15.9	34.92	32	26.0	22.0	32.5	42.6
AL-22M	22	18.3	34.92	32	26.0	22.0	32.5	42.6
AL-25M	25	21.8	34.92	38	31.3	26.5	36.8	49.1
AL-28M	28	21.8	41.0	46	36.6	36.6	43.2	64.0
AL-32M	32	28.6	46.0	50	42.0	41.6	49.3	72.3
AL-38M	38	33.7	55.0	60	49.4	47.9	56.4	84.0

# M Tube Fittings®

## Reducing Union Elbow

### ALR

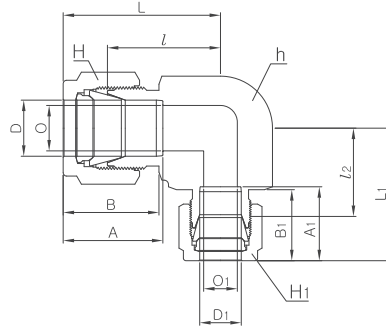
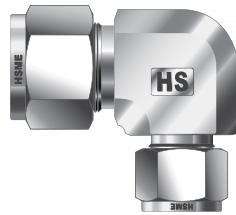

Connects fractional tube

Part No.	Tube O.D.				Width across flat						O	O1	A	A <sub>1</sub>	B	B <sub>1</sub>	/	/1	L	L1
	D		D1		h		H		H1											
	in	mm	in	mm	in	mm	in	mm												
ALR2-1	1/8	3.17	1/16	1.59	3/8	9.52	7/16	11.11	5/16	7.93	2.4	1.3	12.7	8.63	15.24	10.93	15.74	14.2	22.35	18.0
ALR4-2	1/4	6.35	1/8	3.17	1/2	12.7	9/16	14.28	7/16	11.11	4.8	2.4	15.24	12.7	17.78	15.24	19.55	17.9	26.92	24.5
ALR6-4	3/8	9.32	1/4	6.35	5/8	15.87	11/16	17.46	9/16	14.28	7.1	4.8	16.76	15.24	19.3	17.78	23.1	21.92	30.47	29.29
ALR8-4	1/2	12.7	1/4	6.35	13/16	20.64	7/8	22.22	9/16	14.28	10.41	4.8	22.86	15.24	21.84	17.78	25.9	24.4	36.06	31.77
ALR8-6	1/2	12.7	3/8	9.52	13/16	20.64	7/8	22.22	11/16	17.46	10.41	7.1	22.86	16.76	21.84	19.30	25.9	25.9	36.06	33.27

Connects metric tube

Part No.	Tube O.D.				Width across flat				O	O1	A	A <sub>1</sub>	B	B <sub>1</sub>	/	/1	L	L1
	D	D1		h		H		H1										
		in	mm	in	mm	mm	in											
ALR8M-4	8	1/4	6.35	9/16	14.28	16	9/16	14.28	6.4	4.8	16.2	15.24	18.6	17.78	21.3	20.6	28.7	28.0

## Union Tee

### AT

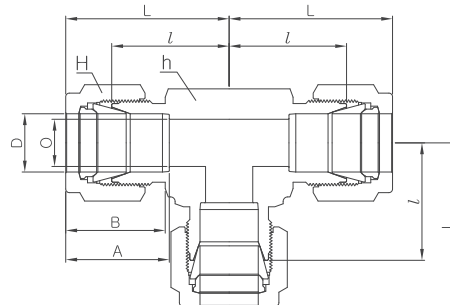
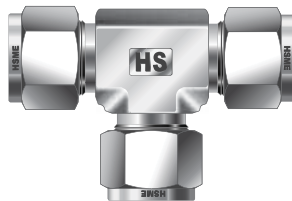

Connects fractional tube

Part No.	Tube O.D.		O Min.	Width across flat				A	B	/	L
	in	mm		h		H					
				in	mm	in	mm				
AT-1	1/16	1.59	1.27	3/8	9.52	5/16	7.93	8.63	10.92	14.00	17.88
AT-2	1/8	3.17	2.28	3/8	9.52	7/16	11.11	12.70	15.24	15.74	22.35
AT-3	3/16	4.76	3.04	1/2	12.70	1/2	12.70	13.71	16.00	17.78	24.38
AT-4	1/4	6.35	4.82	1/2	12.70	9/16	14.28	15.24	17.78	19.55	26.92
AT-5	5/16	7.93	6.35	9/16	14.28	5/8	15.87	16.25	18.54	21.33	28.70
AT-6	3/8	9.52	7.11	5/8	15.87	11/16	17.46	16.76	19.30	23.11	30.48
AT-8	1/2	12.70	10.41	13/16	20.64	7/8	22.22	22.86	21.84	25.90	36.06
AT-10	5/8	15.87	12.70	15/16	23.81	1	25.40	24.38	21.84	28.70	38.80
AT-12	3/4	19.05	15.74	1-1/16	26.98	1-1/8	28.58	24.38	21.84	29.71	39.87
AT-14	7/8	22.22	18.28	1-3/8	34.92	1-1/4	31.75	25.90	21.84	34.54	44.70
AT-16	1	25.40	22.35	1-3/8	34.92	1-1/2	38.10	31.24	26.41	36.83	49.02
AT-20	1-1/4	31.75	27.68	1-11/16	42.86	1-7/8	47.63	41.14	38.86	44.50	66.54
AT-24	1-1/2	38.10	34.03	2	50.80	2-1/4	57.15	50.03	45.21	50.80	77.97
AT-32	2	50.80	45.97	2-3/4	69.85	3	76.20	67.56	62.73	69.80	107.18



## Reducing Union Tee ATR

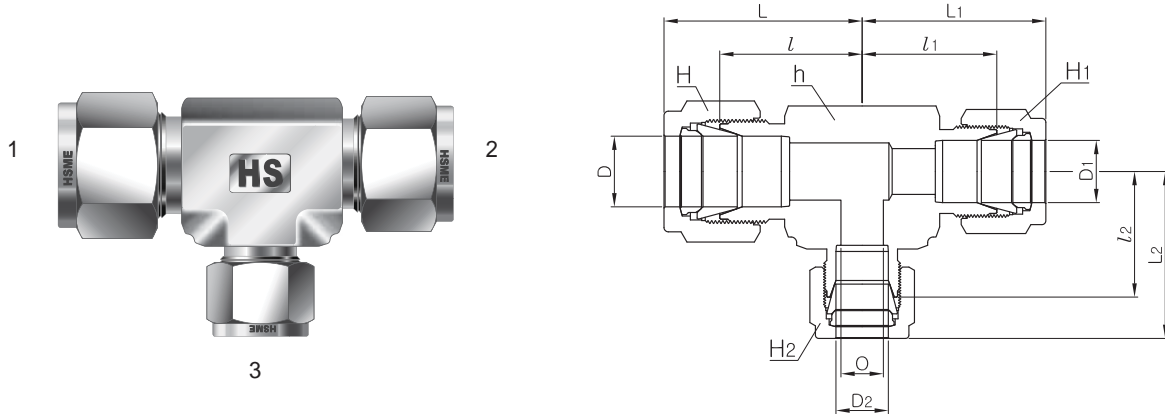

Connects metric tube

Part No.	Port 1	Port 2	Port 3	O Min.	Width across flat				l	l1	l2	L	L1	L2
	D	D1	D2		h	H	H1	H2						
ATR3M-3M-6M	3	3	6	2.4	12.7	12	12	14	18.0	18.0	19.6	24.6	24.6	27.0
ATR8M-8M-6M	8	8	6	4.8	15.	16	16	14	21.3	21.3	20.5	28.8	28.8	28.0
ATR10M-10M-6M	10	10	6	4.8	17.4	19	19	14	23.9	23.9	22.4	31.5	31.5	29.8
ATR10M-10M-12M	10	10	12	7.9	20.6	19	19	22	25.9	25.9	25.9	33.5	33.5	36.0
ATR12M-6M-10M	12	6	10	4.8	20.6	22	14	19	25.9	24.4	25.9	36.0	31.8	33.5
ATR12M-6M-12M	12	6	12	4.8	20.6	22	14	22	25.9	24.4	25.9	36.0	31.8	36.0
ATR12M-10M-10M	12	10	10	7.9	20.6	22	19	19	25.9	25.9	25.9	36.0	33.5	33.5
ATR12M-12M-10M	12	12	10	7.9	20.6	22	22	19	25.9	25.9	25.9	36.0	36.0	33.5
ATR12M-12M-6M	12	12	6	4.8	20.6	22	22	14	25.9	25.9	24.4	36.0	36.0	31.8
ATR15M-15M-12M	15	15	12	9.8	25.4	25	25	22	28.7	28.7	28.7	38.8	38.8	38.8
ATR16M-16M-12M	16	16	12	9.8	25.4	25	25	22	28.7	28.7	28.7	38.8	38.8	38.8
ATR18M-18M-12M	18	18	12	9.8	27	30	30	22	29.7	29.7	28.2	39.8	39.8	38.3
ATR20M-12M-20M	20	12	20	9.8	34.9	32	22	32	32.5	32.5	32.5	42.6	42.6	42.6
ATR20M-20M-6M	20	20	6	4.8	34.9	32	32	14	32.5	32.5	31.0	42.6	42.6	38.4
ATR20M-20M-10M	20	20	10	7.9	34.9	32	32	19	32.5	32.5	32.5	42.6	42.6	40.1
ATR20M-20M-12M	20	20	12	9.8	34.9	32	32	22	32.5	32.5	32.5	42.6	42.6	42.6
ATR20M-20M-25M	20	20	25	15.9	34.9	32	32	38	34.3	34.3	36.8	44.4	44.4	49.1
ATR20M-20M-32M	20	20	32	15.9	46	32	32	50	42.5	42.5	49.3	52.6	52.6	72.3
ATR22M-22M-12M	22	20	12	9.8	34.9	32	32	22	32.5	32.5	32.5	42.6	42.6	42.6
ATR25M-20M-20M	25	20	20	15.9	34.9	38	32	32	36.8	34.3	34.3	49.1	44.4	44.4
ATR25M-25M-10M	25	25	10	7.9	34.9	38	38	19	36.8	36.8	34.3	49.1	49.1	38.9
ATR25M-25M-12M	25	25	12	9.8	34.9	38	38	22	36.8	36.8	34.3	49.1	49.1	44.4
ATR25M-25M-20M	25	25	20	15.9	34.9	38	38	32	36.8	36.8	34.3	49.1	49.1	44.4
ATR32M-32M-20M	32	32	20	15.9	46	38	38	32	49.3	49.3	42.5	72.3	72.3	52.6
ATR38M-32M-32M	38	32	32	28.6	50.8	60	38	38	56.4	54.7	54.7	84.0	77.7	77.7
ATR38M-38M-20M	38	38	20	15.9	50.8	60	60	32	56.4	56.4	47.9	84.0	84.0	58.0
ATR38M-38M-25M	38	38	25	21.8	50.8	60	60	38	56.4	56.4	50.4	84.0	84.0	62.7



Union Cross  
**AX**

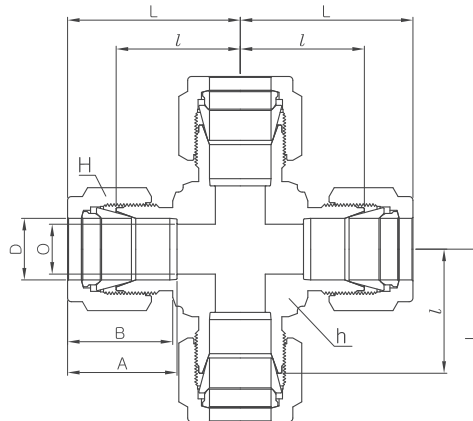
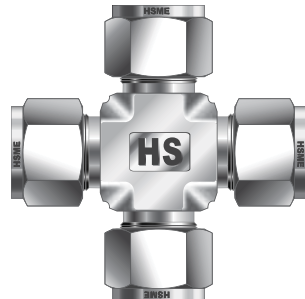

Connects fractional tube

Part No.	Tube O.D. D		O Min.	Width across flat				A	B	/	L
	in	mm		h		H					
				in	mm	in	mm				
AX- 1	1/16	1.59	1.27	3/8	9.52	5/16	7.93	8.63	10.92	14.00	17.88
AX- 2	1/8	3.17	2.28	3/8	9.52	7/16	11.11	12.70	15.24	15.74	22.35
AX- 3	3/16	4.76	3.04	1/2	12.70	1/2	12.70	13.71	16.00	17.78	24.38
AX- 4	1/4	6.35	4.82	1/2	12.70	9/16	14.28	15.24	17.78	19.55	26.92
AX- 5	5/16	7.93	6.35	9/16	14.28	5/8	15.87	16.25	18.54	21.33	28.70
AX- 6	3/8	9.52	7.11	5/8	15.87	11/16	17.46	16.76	19.30	23.11	30.48
AX- 8	1/2	12.70	10.41	13/16	20.64	7/8	22.22	22.86	21.84	25.90	36.06
AX-10	5/8	15.87	12.70	15/16	23.81	1	25.40	24.38	21.84	28.70	38.80
AX-12	3/4	19.05	15.74	1-1/16	26.98	1-1/8	28.58	24.38	21.84	29.71	39.87
AX-14	7/8	22.22	18.28	1-3/8	34.92	1-1/4	31.75	25.90	21.84	34.54	44.70
AX-16	1	25.40	22.35	1-3/8	34.92	1-1/2	38.10	31.24	26.41	36.83	49.02
AX-20	1-1/4	31.75	27.68	1-11/16	42.86	1-7/8	47.63	41.14	38.86	44.50	66.54
AX-24	1-1/2	38.10	34.03	2	50.80	2-1/4	57.15	50.03	45.21	50.80	77.97
AX-32	2	50.80	45.97	2-3/4	69.85	3	76.20	67.56	62.73	69.80	107.18

Connects metric tube

Part No.	Tube O.D. D	O Min.	Width across flat		A	B	/	L
			h	H				
AX- 2M	2	1.7	9.5	12	12.9	15.3	15.7	22.3
AX- 3M	3	2.4	9.5	12	12.9	15.3	15.7	22.3
AX- 4M	4	2.4	12.7	12	13.7	16.4	18.8	25.4
AX- 6M	6	4.8	12.7	14	15.3	17.7	19.6	27.0
AX- 8M	8	6.4	14.3	16	16.2	18.6	21.3	28.8
AX-10M	10	7.9	17.5	19	17.2	19.5	23.9	31.5
AX-12M	12	9.5	20.6	22	22.8	22.0	25.9	36.0
AX-15M	15	11.9	25.4	25	24.4	22.0	28.7	38.8
AX-16M	16	12.7	25.4	25	24.4	22.0	28.7	38.8
AX-18M	18	15.1	27.0	30	24.4	22.0	29.7	39.8
AX-20M	20	15.9	34.92	32	26.0	22.0	32.5	42.6
AX-22M	22	18.3	34.92	32	26.0	22.0	32.5	42.6
AX-25M	25	21.8	34.92	38	31.3	26.5	36.8	49.1
AX-28M	28	21.8	41.0	46	36.6	36.6	43.2	64.0
AX-32M	32	28.6	46.0	50	42.0	41.6	49.3	72.3
AX-38M	38	33.7	55.0	60	49.4	47.9	56.4	84.0

# M Tube Fittings®

## Reducing Union Cross AXR

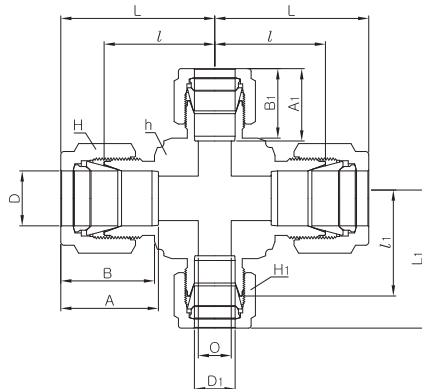
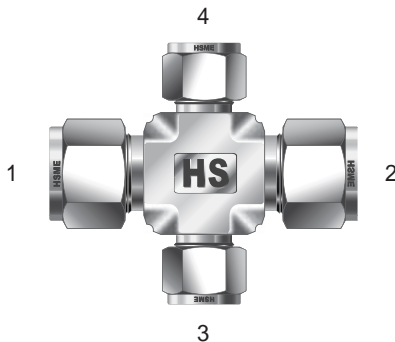

Connects fractional tube

Part No.	Port 1	Port 2	Port 3	Port 4	O Min.	Width Across flat						A	A1	B	B1	/	/1	L	L1
	D		D1			h		H		H1									
	in	mm	in	Mm		in	mm	in	mm	in	mm								
AXR 12-12-6-6	3/4	19.05	3/8	9.52	7.1	1-1/16	26.98	1-1/8	28.57	11/16	17.46	24.38	16.76	21.84	19.3	29.71	29.71	39.87	37.07

Connects metric tube

Part No.	Port 1	Port 2	Port 3	Port 4	O Min.	Width Across flat						A	A1	B	B1	/	/1	L	L1	
	D		D1			h		H		H1										
	in	mm	in	Mm		in	mm	in	mm	in	mm									
AXR16M-6M-6M-6M	16		6		4.8	25.4	25	14	24.4	15.3	22.0	17.7	28.7	27.2	38.8	34.6				

## Bored-Through Fittings

For Dip Tubes, Thermocouples, and Heat Exchanger Fittings

## AMCT / ART

Bored-through fitting has no tube shoulder, allowing Dip tube of Thermocouple to pass through the fitting.

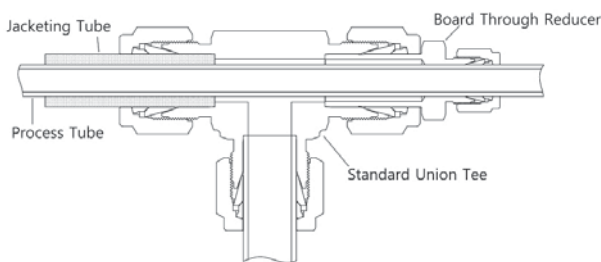
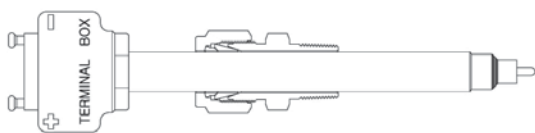

Most male connectors –**AMC** can be bored-through except those fittings with 1/8 in. NPT or BSPT end.

To order bored-through male connector, add **T** to the ordering number. Example: AMCT8-8N-SSA

The combination of standard tee and bored-through port reducer –**AR** can be used to chill or heat a process line as heat exchanger fitting.

To order bored-through port reducer, add **T** to the ordering number. Example: ART8-8-SSA

**Diagram shown;**  
Jacketing tube 1/2 in. OD  
Process tube: 1/4 in. OD

- Thermocouple is a sensor for measuring temperature.
- Dip tube is to direct the incoming cold water to the bottom of water heater tank or to use for removing debris from the bottom of water tank.

### Assembly Instruction

1. Position the length of dip tube / thermocouple passed through the fitting.
2. Once positioned, hold it to prevent from shifting during assembly.
3. Wrench tightens the nut 1 1/4 turns from finger-tight position, keeping the body steady with a backup wrench.

Male NPT Connector  
**AMC-N**

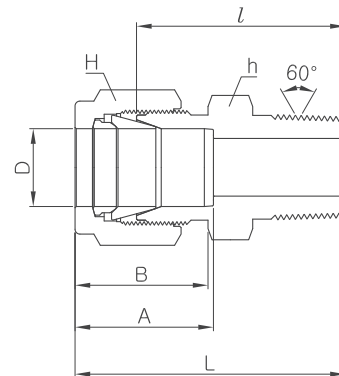
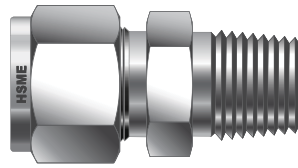

Connects fractional tube to female NPT thread

Part No.	Tube O.D. D		T NPT	O Min.	Width across flat				A	B	/	L
	in	mm			h		H					
					in	mm	in	mm				
AMC1-1N	1/16	1.59	1/16	1.27	5/16	7.93	5/16	7.93	8.63	10.92	20.00	23.83
AMC1-2N	1/16	1.59	1/8	1.27	7/16	11.11	5/16	7.93	8.63	10.92	22.35	26.23
AMC1-4N	1/16	1.59	1/4	1.27	9/16	14.28	5/16	7.93	8.63	10.92	27.17	30.98
AMC2-1N	1/8	3.17	1/16	2.28	7/16	11.11	7/16	11.11	12.70	15.24	23.11	29.71
AMC2-2N	1/8	3.17	1/8	2.28	7/16	11.11	7/16	11.11	12.70	15.24	23.87	30.48
AMC2-4N	1/8	3.17	1/4	2.28	9/16	14.28	7/16	11.11	12.70	15.24	28.95	35.56
AMC2-6N	1/8	3.17	3/8	2.28	11/16	17.46	7/16	11.11	12.70	15.24	29.21	35.81
AMC2-8N	1/8	3.17	1/2	2.28	7/8	22.22	7/16	11.11	12.70	15.24	35.56	42.16
AMC3-2N	3/16	4.76	1/8	3.04	7/16	11.11	1/2	12.70	13.71	16.00	24.63	31.24
AMC3-4N	3/16	4.76	1/4	3.04	9/16	14.28	1/2	12.70	13.71	16.00	29.71	36.32
AMC4-1N	1/4	6.35	1/16	4.82	1/2	12.70	9/16	14.28	15.24	17.78	25.40	32.76
AMC4-2N	1/4	6.35	1/8	4.82	1/2	12.70	9/16	14.28	15.24	17.78	25.40	32.76
AMC4-4N	1/4	6.35	1/4	4.82	9/16	14.28	9/16	14.28	15.24	17.78	30.48	37.84
AMC4-6N	1/4	6.35	3/8	4.82	11/16	17.46	9/16	14.28	15.24	17.78	30.98	38.35
AMC4-8N	1/4	6.35	1/2	4.82	7/8	22.22	9/16	14.28	15.24	17.78	37.33	44.70
AMC4-12N	1/4	6.35	3/4	4.82	1-1/6	26.98	9/16	14.28	15.24	17.78	38.86	46.22
AMC5-2N	5/16	7.93	1/8	4.82	9/16	14.28	5/8	15.87	16.25	18.54	26.67	34.03
AMC5-4N	5/16	7.93	1/4	6.35	9/16	14.28	5/8	15.87	16.25	18.54	31.24	38.60
AMC5-6N	5/16	7.93	3/8	6.35	11/16	17.46	5/8	15.87	16.25	18.54	31.75	39.11
AMC5-8N	5/16	7.93	1/2	6.35	7/8	22.22	5/8	15.87	16.25	18.54	38.11	45.60
AMC6-2N	3/8	9.52	1/8	4.82	5/8	15.87	11/16	17.46	16.76	19.30	27.94	35.30
AMC6-4N	3/8	9.52	1/4	7.11	5/8	15.87	11/16	17.46	16.76	19.30	32.51	39.87
AMC6-6N	3/8	9.52	3/8	7.11	11/16	17.46	11/16	17.46	16.76	19.30	32.51	39.87
AMC6-8N	3/8	9.52	1/2	7.11	7/8	22.22	11/16	17.46	16.76	19.30	38.86	46.22
AMC6-12N	3/8	9.52	3/4	7.11	1-1/16	26.98	11/16	17.46	16.76	19.30	40.38	47.75
AMC8-2N	1/2	12.70	1/8	4.82	13/16	20.64	7/8	22.22	22.86	21.84	28.70	38.86
AMC8-4N	1/2	12.70	1/4	7.11	13/16	20.64	7/8	22.22	22.86	21.84	33.27	43.43
AMC8-6N	1/2	12.70	3/8	9.65	13/16	20.64	7/8	22.22	22.86	21.84	33.27	43.43
AMC8-8N	1/2	12.70	1/2	10.41	7/8	22.22	7/8	22.22	22.86	21.84	38.86	49.02
AMC8-12N	1/2	12.70	3/4	10.41	1-1/16	26.98	7/8	22.22	22.86	21.84	40.38	50.54
AMC8-16N	1/2	12.70	1	10.41	1-3/8	34.92	7/8	22.22	22.86	21.84	46.99	57.15
AMC10-6N	5/8	15.87	3/8	9.65	15/16	23.81	1	25.40	24.38	21.84	34.03	44.19
AMC10-8N	5/8	15.87	1/2	11.93	15/16	23.81	1	25.40	24.38	21.84	38.86	49.02
AMC10-12N	5/8	15.87	3/4	12.70	1-1/16	26.98	1	25.40	24.38	21.84	40.38	50.54
AMC12-8N	3/4	19.05	1/2	11.93	1-1/16	26.98	1-1/8	28.58	24.38	21.84	40.38	50.54
AMC12-12N	3/4	19.05	3/4	15.74	1-1/16	26.98	1-1/8	28.58	24.38	21.84	40.38	50.54
AMC12-16N	3/4	19.05	1	15.74	1-3/8	34.92	1-1/8	28.58	24.38	21.84	46.99	57.15
AMC14-12N	7/8	22.22	3/4	15.74	1-3/16	30.16	1-1/4	31.75	25.90	21.84	40.38	50.54
AMC14-16N	7/8	22.22	1	18.28	1-3/8	34.92	1-1/4	31.75	25.90	21.84	46.99	57.15
AMC16-8N	1	25.40	1/2	11.93	1-3/8	34.92	1-1/2	38.10	31.24	26.41	45.21	57.40
AMC16-12N	1	25.40	3/4	15.74	1-3/8	34.92	1-1/2	38.10	31.24	26.41	45.21	57.40
AMC16-16N	1	25.40	1	22.35	1-3/8	34.62	1-1/2	38.10	31.24	26.41	50.03	62.23
AMC20-16N	1-1/4	31.75	1	22.35	1-3/4	44.45	1-7/8	47.63	41.14	38.86	55.11	77.21
AMC20-20N	1-1/4	31.75	1-1/4	27.68	1-3/4	44.45	1-7/8	47.63	41.14	38.86	55.11	77.21
AMC20-24N	1-1/4	31.75	1-1/2	27.68	1-3/4	44.45	1-7/8	47.63	41.14	38.86	60.54	82.64
AMC24-20N	1-1/2	38.10	1-1/4	27.68	2-1/8	53.98	2-1/4	57.15	50.03	45.21	59.42	86.60
AMC24-24N	1-1/2	38.10	1-1/2	34.03	2-1/8	53.98	2-1/4	57.15	50.03	45.21	61.72	88.90
AMC24-32N	1-1/2	38.10	2	34.03	2-3/4	69.85	2-1/4	57.15	50.03	45.21	62.42	99.75
AMC32-8N	2	50.80	1/2	11.93	2-3/4	69.85	3	76.20	67.56	62.73	68.40	105.73
AMC32-20N	2	50.80	1-1/4	45.97	2-3/4	69.85	3	76.20	67.56	62.73	71.40	108.73
AMC32-24N	2	50.80	1-1/2	45.97	2-3/4	69.85	3	76.20	67.56	62.73	75.50	112.83
AMC32-32N	2	50.80	2	45.97	2-3/4	69.85	3	76.20	67.56	62.73	76.20	113.53

## Male NPT Connector AMC-N

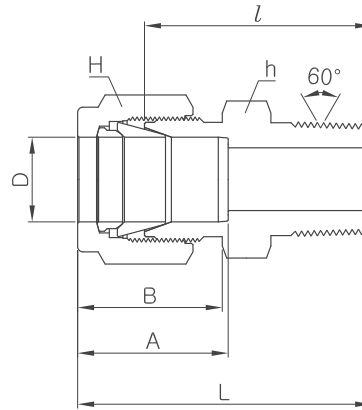
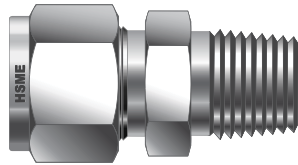

Connects metric tube to female NPT thread

Part No.	Tube O.D. D	T NPT	E Min.	Width across flat		A	B	/	L
				h	H				
AMC2M-2N	2	1/8	1.7	12	12	12.9	15.3	23.9	30.5
AMC3M-2N	3	1/8	2.4	12	12	12.9	15.3	23.1	29.7
AMC3M-4N	3	1/4	2.4	14	12	12.9	15.3	29.0	35.6
AMC4M-2N	4	1/8	2.4	12	12	13.7	16.1	24.6	31.2
AMC4M-4N	4	1/4	2.4	14	12	13.7	16.1	29.7	36.3
AMC6M-2N	6	1/8	4.8	14	14	15.3	17.7	25.4	32.8
AMC6M-4N	6	1/4	4.8	14	14	15.3	17.7	30.2	37.6
AMC6M-6N	6	3/8	4.8	18	14	15.3	17.7	31.0	38.4
AMC6M-8N	6	1/2	4.8	22	14	15.3	17.7	37.3	44.0
AMC8M-2N	8	1/8	4.8	15	16	16.2	18.6	26.7	34.2
AMC8M-4N	8	1/4	6.4	15	16	16.2	18.6	31.2	38.7
AMC8M-6N	8	3/8	6.4	18	16	16.2	18.6	31.8	39.2
AMC8M-8N	8	1/2	6.4	22	16	16.2	18.6	37.3	44.8
AMC10M-2N	10	1/8	4.8	18	19	17.2	19.5	28.7	36.3
AMC10M-4N	10	1/4	7.1	18	19	17.2	19.5	33.3	40.9
AMC10M-6N	10	3/8	7.9	18	19	17.2	19.5	33.3	40.9
AMC10M-8N	10	1/2	7.9	22	19	17.2	19.5	38.1	45.7
AMC10M-12N	10	3/4	7.9	27	19	17.2	19.5	38.9	46.5
AMC12M-2N	12	1/8	4.8	22	22	22.8	22.0	28.7	38.8
AMC12M-4N	12	1/4	7.1	22	22	22.8	22.0	33.3	43.4
AMC12M-6N	12	3/8	9.5	22	22	22.8	22.0	33.3	43.4
AMC12M-8N	12	1/2	9.5	22	22	22.8	22.0	38.1	48.2
AMC12M-12N	12	3/4	9.5	27	22	22.8	22.0	38.9	49.0
AMC14M-4N	14	1/4	6.4	24	25	24.4	22.0	34.0	44.1
AMC14M-6N	14	3/8	9.5	24	25	24.4	22.0	34.0	44.1
AMC14M-8N	14	1/2	11.1	24	25	24.4	22.0	34.0	44.1
AMC15M-8N	15	1/2	11.9	24	25	24.4	22.0	38.9	49.0
AMC16M-4N	16	1/4	7.1	24	25	24.4	22.0	34.0	44.1
AMC16M-6N	16	3/8	9.5	24	25	24.4	22.0	34.0	44.1
AMC16M-8N	16	1/2	11.9	24	25	24.4	22.0	38.9	49.0
AMC16M-12N	16	3/4	12.7	27	25	24.4	22.0	38.9	49.0
AMC18M-8N	18	1/2	11.9	27	30	24.4	22.0	40.4	50.5
AMC18M-12N	18	3/4	15.1	27	30	24.4	22.0	40.4	50.5
AMC20M-8N	20	1/2	11.9	30	32	26.0	22.0	42.2	52.3
AMC20M-12N	20	3/4	15.9	30	32	26.0	22.0	42.2	52.3
AMC22M-12N	22	3/4	15.9	30	32	26.0	22.0	42.2	52.3
AMC22M-16N	22	1	18.3	35	32	26.0	22.0	47.8	57.9
AMC25M-8N	25	1/2	11.9	35	38	31.3	26.5	45.2	57.5
AMC25M-12N	25	3/4	15.9	35	38	31.3	26.5	45.2	57.5
AMC25M-16N	25	1	21.8	35	38	31.3	26.5	50.0	62.3
AMC28M-16N	28	1	21.8	41	46	36.6	36.6	51.6	72.4
AMC28M-20N	28	1-1/4	21.8	46	46	36.6	36.6	52.3	73.1
AMC32M-20N	32	1-1/4	28.6	46	50	42.0	41.6	56.6	79.6
AMC38M-24N	38	1-1/2	33.7	55	60	49.4	47.9	64.0	91.6

Bulkhead Male NPT Connector  
**AMCB-N**

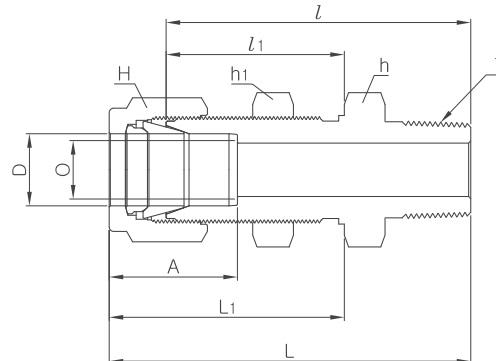
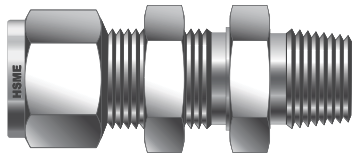

Connects fractional tube to female NPT thread

Part No.	Tube O.D. D		T NPT	O Min.	Width across flat						A	/	/1	L	L1	Panel Hole Drill Size	Panel Max Thickness
	in	mm			h		h1		H								
					in	mm	in	mm	in	mm							
AMCB2-2N	1/8	3.17	1/8	2.28	1/2	12.70	1/2	12.70	7/16	11.11	12.70	39.87	24.63	46.48	31.24	8.33	12.70
AMCB4-2N	1/4	6.35	1/8	4.82	5/8	15.87	5/8	15.87	9/16	14.28	15.24	42.16	26.16	49.53	33.52	11.50	10.16
AMCB4-4N	1/4	6.35	1/4	4.82	5/8	15.87	5/8	15.87	9/16	14.28	15.24	45.97	26.16	53.34	33.52	11.50	10.16
AMCB6-4N	3/8	9.52	1/4	7.11	3/4	19.05	3/4	19.05	11/16	17.46	16.76	50.03	29.46	57.40	36.83	14.68	11.17
AMCB6-6N	3/8	9.52	3/8	7.11	3/4	19.05	3/4	19.05	11/16	17.46	16.76	50.03	29.46	57.40	36.83	14.68	11.17
AMCB6-8N	3/8	9.52	1/2	7.11	7/8	22.22	3/4	19.05	11/16	17.46	16.76	56.38	29.46	63.75	36.83	14.68	11.17
AMCB8-6N	1/2	12.70	3/8	9.39	15/16	23.81	15/16	23.81	7/8	22.22	22.86	53.08	31.75	63.24	41.91	19.44	12.70
AMCB8-8N	1/2	12.70	1/2	10.41	15/16	23.81	15/16	23.81	7/8	22.22	22.86	58.67	31.75	68.83	41.91	19.44	12.70
AMCB12-12N	3/4	19.05	3/4	15.74	1-3/16	30.16	1-3/16	30.16	1-1/8	28.58	24.38	66.04	37.33	76.20	47.49	25.76	16.76
AMCB16-16N	1	25.40	1	22.35	1-5/8	41.28	1-5/8	41.28	1-1/2	38.10	31.24	81.02	45.21	93.21	57.40	33.73	19.05
AMCB20-20N	1-1/4	31.75	1-1/4	27.68	1-7/8	47.63	1-7/8	47.63	1-7/8	47.63	41.14	85.97	47.75	108.07	69.85	41.67	19.05
AMCB24-24N	1-1/2	38.10	1-1/2	34.03	2-1/4	57.15	2-1/4	57.15	2-1/4	57.15	50.03	93.03	49.27	120.21	76.45	49.61	19.05
AMCB32-32N	2	50.80	2	45.97	2-3/4	69.85	2-3/4	69.85	3	76.20	67.56	107.29	56.38	144.62	93.71	16.27	19.05

Connects metric tube to female NPT thread

Part No.	Tube O.D. D	T NPT	O Min.	Width across flat			A	/	/1	L	L1	Panel Hole Drill size	Panel Max Thickness
				h	h1	H							
AMCB6M-2N	6	1/8	2.28	16	16	14	15.3	42.2	26.2	49.6	33.6	11.5	10.2
AMCB6M-4N	6	1/8	4.82	16	16	14	15.3	46.2	26.2	53.6	33.6	11.5	10.2
AMCB6M-6N	6	1/4	4.82	16	16	14	15.3	46.2	26.2	53.6	33.6	11.5	10.2
AMCB6M-8N	6	1/4	7.11	16	16	14	15.3	52.6	26.2	60.0	33.6	11.5	10.2
AMCB8M-6N	8	3/8	7.11	18	18	16	16.2	50.0	28.6	57.5	36.1	13.1	11.2
AMCB10M-4N	10	1/2	7.11	22	22	19	17.2	50.0	29.4	57.5	37.0	16.2	11.2
AMCB10M-6N	10	3/8	9.39	22	22	19	17.2	50.0	29.4	57.5	37.0	16.2	11.2
AMCB10M-8N	10	1/2	10.41	22	22	19	17.2	55.9	29.4	63.5	37.0	16.2	11.2
AMCB12M-6N	12	3/4	15.74	24	24	22	22.8	53.3	31.8	63.4	41.9	19.5	12.7
AMCB12M-8N	12	1	22.35	24	24	22	22.8	58.7	31.8	68.8	41.9	19.5	12.7
AMCB20-20N	1-1/4	1-1/4	27.68	1-7/8	1-7/8	1-7/8	41.14	85.97	47.75	108.07	69.85	41.67	19.05
AMCB24-24N	1-1/2	1-1/2	34.03	2-1/4	2-1/4	2-1/4	50.03	93.03	49.27	120.21	76.45	49.61	19.05
AMCB32-32N	2	2	45.97	2-3/4	2-3/4	3	67.56	107.29	56.38	144.62	93.71	16.27	19.05

## • Male BSPT Connector **AMC-R**

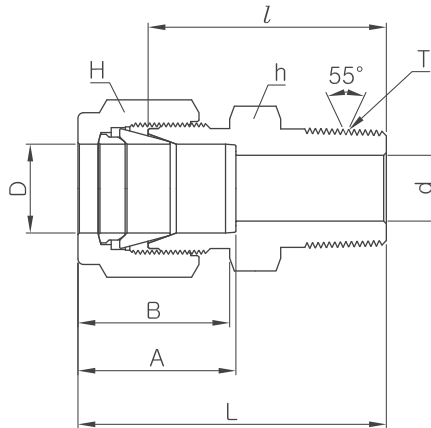
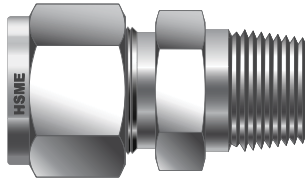

Connects fractional tube to female ISO tapered thread

Part No.	Tube O.D. D		T PT	O Min.	Width across flat				A	B	/	L
	in	mm			h		H					
					in	mm	in	mm				
AMC2-2R	1/8	3.17	1/8	2.28	7/16	11.11	7/16	11.11	12.70	15.24	23.87	30.48
AMC2-4R	1/8	3.17	1/4	2.28	9/16	14.28	7/16	11.11	12.70	15.24	28.95	35.56
AMC4-2R	1/4	6.35	1/8	4.82	1/2	12.70	9/16	14.28	15.24	17.78	25.40	32.76
AMC4-4R	1/4	6.35	1/4	4.82	9/16	14.28	9/16	14.28	15.24	17.78	30.48	37.84
AMC4-6R	1/4	6.35	3/8	4.82	11/16	17.46	9/16	14.28	15.24	17.78	30.98	38.35
AMC4-8R	1/4	6.35	1/2	4.82	7/8	22.22	9/16	14.28	15.24	17.78	37.33	44.70
AMC5-2R	5/16	7.93	1/8	4.82	9/16	14.28	5/8	15.87	16.25	18.54	26.67	34.03
AMC5-4R	5/16	7.93	1/4	6.35	9/16	14.28	5/8	15.87	16.25	18.54	31.24	38.60
AMC5-16R	5/16	7.93	1	6.35	1-3/8	34.92	5/8	15.87	16.25	18.54	46.2	50.0
AMC6-2R	3/8	9.52	1/8	4.82	5/8	15.87	11/16	17.46	16.76	19.30	27.94	35.30
AMC6-4R	3/8	9.52	1/4	7.11	5/8	15.87	11/16	17.46	16.76	19.30	32.51	39.87
AMC6-6R	3/8	9.52	3/8	7.11	11/16	17.46	11/16	17.46	16.76	19.30	32.51	39.87
AMC6-8R	3/8	9.52	1/2	7.11	7/8	22.22	11/16	17.46	16.76	19.30	38.86	46.22
AMC6-12R	3/8	9.52	3/4	7.11	1-1/16	26.98	11/16	17.46	16.76	19.30	40.38	47.75
AMC8-2R	1/2	12.70	1/8	4.82	13/16	20.64	7/8	22.22	22.86	21.84	28.70	38.86
AMC8-4R	1/2	12.70	1/4	7.11	13/16	20.64	7/8	22.22	22.86	21.84	33.27	43.43
AMC8-6R	1/2	12.70	3/8	9.65	13/16	20.64	7/8	22.22	22.86	21.84	33.27	43.43
AMC8-8R	1/2	12.70	1/2	10.41	7/8	22.22	7/8	22.22	22.86	21.84	38.86	49.02
AMC8-12R	1/2	12.70	3/4	10.41	1-1/16	26.98	7/8	22.22	22.86	21.84	40.38	50.54
AMC8-16R	1/2	12.70	1	10.41	1-3/8	34.92	7/8	22.22	22.86	21.84	46.99	57.15
AMC10-6R	5/8	15.87	3/8	9.65	15/16	23.81	1	25.40	24.38	21.84	34.03	44.19
AMC10-8R	5/8	15.87	1/2	11.93	15/16	23.81	1	25.40	24.38	21.84	38.86	49.02
AMC10-12R	5/8	15.87	3/4	12.70	1-1/16	26.98	1	25.40	24.38	21.84	40.38	50.54
AMC12-8R	3/4	19.05	1/2	11.93	1-1/16	26.98	1-1/8	28.58	24.38	21.84	40.38	50.54
AMC12-12R	3/4	19.05	3/4	15.74	1-1/16	26.98	1-1/8	28.58	24.38	21.84	40.38	50.54
AMC12-16R	3/4	19.05	1	15.74	1-3/8	34.92	1-1/8	28.58	24.38	21.84	46.99	57.15
AMC16-12R	1	25.40	3/4	15.74	1-3/8	34.92	1-1/2	38.10	31.24	26.41	45.21	57.40
AMC16-16R	1	25.40	1	22.35	1-3/8	34.62	1-1/2	38.10	31.24	26.41	50.03	62.23
AMC20-12R	1-1/4	31.75	3/4	15.74	1-3/4	44.45	1-7/8	47.63	41.14	38.86	50.0	72.10
AMC20-16R	1-1/4	31.75	1	22.35	1-3/4	44.45	1-7/8	47.63	41.14	38.86	55.11	77.21
AMC20-20R	1-1/4	31.75	1-1/4	27.68	1-3/4	44.45	1-7/8	47.63	41.14	38.86	55.11	77.21
AMC32-32R	2	50.80	2	45.97	2-3/4	69.85	3	76.20	67.56	62.73	76.20	113.53

Male BSPT Connector  
**AMC-R**

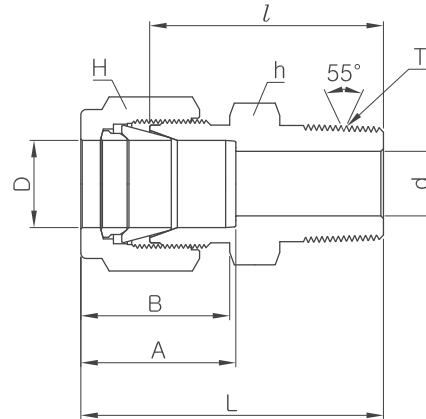
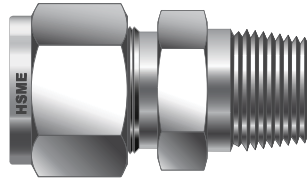

Connects metric tube to female ISO tapered thread

Part No.	Tube O.D. D	T R(PT)	O Min.	Width across flat		A	B	/	L
				h	H				
AMC2M-2R	2	1/8	1.7	12	12	12.9	15.3	23.9	30.5
AMC3M-2R	3	1/8	2.4	12	12	12.9	15.3	23.1	29.7
AMC3M-4R	3	1/4	2.4	14	12	12.9	15.3	29.0	35.6
AMC4M-2R	4	1/8	2.4	12	12	13.7	16.1	24.6	31.2
AMC4M-4R	4	1/4	2.4	14	12	13.7	16.1	29.7	36.3
AMC6M-2R	6	1/8	4.8	14	14	15.3	17.7	25.4	32.8
AMC6M-4R	6	1/4	4.8	14	14	15.3	17.7	30.2	37.6
AMC6M-6R	6	3/8	4.8	18	14	15.3	17.7	31.0	38.4
AMC6M-8R	6	1/2	4.8	22	14	15.3	17.7	37.3	44.0
AMC8M-2R	8	1/8	4.8	15	16	16.2	18.6	26.7	34.2
AMC8M-4R	8	1/4	6.4	15	16	16.2	18.6	31.2	38.7
AMC8M-6R	8	3/8	6.4	18	16	16.2	18.6	31.8	39.2
AMC8M-8R	8	1/2	6.4	22	16	16.2	18.6	37.3	44.8
AMC10M-2R	10	1/8	4.8	18	19	17.2	19.5	28.7	36.3
AMC10M-4R	10	1/4	7.1	18	19	17.2	19.5	33.3	40.9
AMC10M-6R	10	3/8	7.9	18	19	17.2	19.5	33.3	40.9
AMC10M-8R	10	1/2	7.9	22	19	17.2	19.5	38.1	45.7
AMC12M-4R	12	1/4	7.1	22	22	22.8	22.0	33.3	43.4
AMC12M-6R	12	3/8	9.5	22	22	22.8	22.0	33.3	43.4
AMC12M-8R	12	1/2	9.5	22	22	22.8	22.0	38.1	48.2
AMC12M-12R	12	3/4	9.5	27	22	22.8	22.0	38.9	49.0
AMC15M-8R	15	1/2	11.9	24	25	24.4	22.0	38.9	49.0
AMC16M-4R	16	1/4	7.1	24	25	24.4	22.0	34.0	44.1
AMC16M-6R	16	3/8	9.5	24	25	24.4	22.0	34.0	44.1
AMC16M-8R	16	1/2	11.9	24	25	24.4	22.0	38.9	49.0
AMC16M-12R	16	3/4	12.7	27	25	24.4	22.0	38.9	49.0
AMC18M-8R	18	1/2	11.9	27	30	24.4	22.0	40.4	50.5
AMC18M-12R	18	3/4	15.1	27	30	24.4	22.0	40.4	50.5
AMC20M-8R	20	1/2	11.9	30	32	26.0	22.0	42.2	52.3
AMC20M-12R	20	3/4	15.9	30	32	26.0	22.0	42.2	52.3
AMC22M-12R	22	3/4	15.9	30	32	26.0	22.0	42.2	52.3
AMC22M-16R	22	1	18.3	35	32	26.0	22.0	47.8	57.9
AMC25M-12R	25	3/4	15.9	35	38	31.3	26.5	45.2	57.5
AMC25M-16R	25	1	21.8	35	38	31.3	26.5	50.0	62.3
AMC28M-16R	28	1	21.8	41	46	36.6	36.6	51.6	72.4
AMC28M-20R	28	1-1/4	21.8	46	46	36.6	36.6	52.3	73.1
AMC32M-20R	32	1-1/4	28.6	46	50	42.0	41.6	56.6	79.6
AMC38M-24R	38	1-1/2	33.7	55	60	49.4	47.9	64.0	91.6

# M Tube Fittings®

- Male ISO Parallel Connector  
DIN3852 Form A  
**AMC-G**

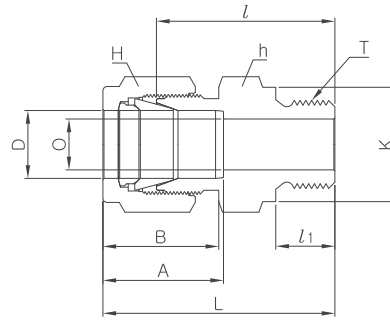
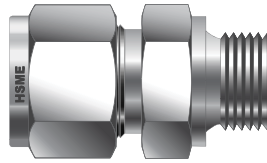

Connects fractional tube to female ISO parallel thread

Part No.	Tube O.D. D		T (PF)	O Min.	Width across flat				A	B	l	l1	L	K
	in	mm			h		H							
					in	mm	in	mm						
AMC2-2G	1/8	3.17	1/8	2.28	9/16	14.28	7/16	11.11	12.70	15.24	23.37	7.11	29.97	13.72
AMC2-4G	1/8	3.17	1/4	2.28	3/4	19.05	7/16	11.11	12.70	15.24	28.70	11.18	35.31	18.03
AMC2-6G	1/8	3.17	3/8	2.28	7/8	22.22	7/16	11.11	12.70	15.24	29.72	11.18	36.21	21.84
AMC4-2G	1/4	6.35	1/8	2.28	9/16	14.28	9/16	14.28	15.24	17.78	24.89	7.11	32.26	13.72
AMC4-4G	1/4	6.35	1/4	4.82	3/4	19.05	9/16	14.28	15.24	17.78	30.23	11.18	37.59	18.03
AMC4-6G	1/4	6.35	3/8	4.82	7/8	22.22	9/16	14.28	15.24	17.78	31.50	11.18	38.86	21.84
AMC4-8G	1/4	6.35	1/2	4.82	1-1/16	26.98	9/16	14.28	15.24	17.78	37.34	14.22	44.70	25.91
AMC6-4G	3/8	9.53	1/4	4.82	3/4	19.05	11/16	17.46	16.76	19.30	31.75	11.18	39.12	18.03
AMC6-6G	3/8	9.53	3/8	7.11	7/8	22.22	11/16	17.46	16.76	19.30	33.02	11.18	40.39	21.84
AMC6-8G	3/8	9.53	1/2	7.11	1-1/16	26.98	11/16	17.46	16.76	19.30	38.86	14.22	46.23	25.91
AMC8-4G	1/2	12.70	1/4	7.11	13/16	20.64	7/8	22.22	22.86	21.84	32.51	11.18	42.67	18.03
AMC8-6G	1/2	12.70	3/8	9.65	7/8	22.22	7/8	22.22	22.86	21.84	33.02	11.18	43.18	21.84
AMC8-8G	1/2	12.70	1/2	10.41	1-1/16	26.98	7/8	22.22	22.86	21.84	38.86	14.22	49.02	25.91
AMC12-8G	3/4	19.05	1/2	11.93	1-1/16	26.98	1-1/8	28.58	24.38	21.84	38.86	14.22	49.02	25.91
AMC12-12G	3/4	19.05	3/4	15.74	1-5/16	33.33	1-1/8	28.58	24.38	21.84	42.67	15.75	52.83	32.00
AMC16-8G	1	25.40	1/2	11.93	1-3/8	34.92	1-1/2	38.10	31.24	26.41	43.69	14.22	55.88	25.91
AMC16-16G	1	25.40	1	22.35	1-5/8	41.27	1-1/2	38.10	31.24	26.41	47.75	18.29	59.94	39.12
AMC20-20G	1-1/4	31.75	1-1/4	27.68	2	50.80	1-7/8	47.63	41.14	38.86	51.16	20.00	73.26	49.00
AMC24-24G	1-1/2	38.10	1-1/2	34.03	2-1/4	57.15	2-1/4	57.15	50.03	45.21	57.57	22.00	84.75	54.70

- Male ISO Parallel Connector  
DIN3852 Form B  
**AMC-GB**

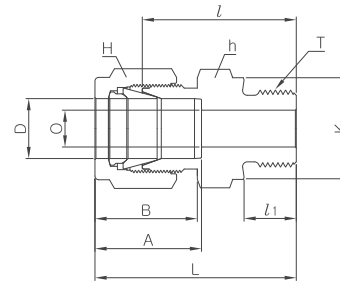
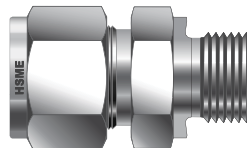

Connects fractional tube to female ISO parallel thread

Part No.	Tube O.D. D		T (PF)	O Min.	Width across flat				A	B	l	l1	L	K
	in	mm			h		H							
					in	mm	in	mm						
AMC2-2GB	1/8	3.17	1/8	2.28	9/16	14.28	7/16	11.11	12.70	15.24	23.37	7.11	29.97	13.72
AMC2-4GB	1/8	3.17	1/4	2.28	3/4	19.05	7/16	11.11	12.70	15.24	28.70	11.18	35.31	18.03
AMC2-6GB	1/8	3.17	3/8	2.28	7/8	22.22	7/16	11.11	12.70	15.24	29.72	11.18	36.21	21.84
AMC4-2GB	1/4	6.35	1/8	2.28	9/16	14.28	9/16	14.28	15.24	17.78	24.89	7.11	32.26	13.72
AMC4-4GB	1/4	6.35	1/4	4.82	3/4	19.05	9/16	14.28	15.24	17.78	30.23	11.18	37.59	18.03
AMC4-6GB	1/4	6.35	3/8	4.82	7/8	22.22	9/16	14.28	15.24	17.78	31.50	11.18	38.86	21.84
AMC4-8GB	1/4	6.35	1/2	4.82	1-1/16	26.98	9/16	14.28	15.24	17.78	37.34	14.22	44.70	25.91
AMC6-4GB	3/8	9.53	1/4	4.82	3/4	19.05	11/16	17.46	16.76	19.30	31.75	11.18	39.12	18.03
AMC6-6GB	3/8	9.53	3/8	7.11	7/8	22.22	11/16	17.46	16.76	19.30	33.02	11.18	40.39	21.84
AMC6-8GB	3/8	9.53	1/2	7.11	1-1/16	26.98	11/16	17.46	16.76	19.30	38.86	14.22	46.23	25.91
AMC8-4GB	1/2	12.70	1/4	7.11	13/16	20.64	7/8	22.22	22.86	21.84	32.51	11.18	42.67	18.03
AMC8-6GB	1/2	12.70	3/8	9.65	7/8	22.22	7/8	22.22	22.86	21.84	33.02	11.18	43.18	21.84
AMC8-8GB	1/2	12.70	1/2	10.41	1-1/16	26.98	7/8	22.22	22.86	21.84	38.86	14.22	49.02	25.91
AMC12-8GB	3/4	19.05	1/2	11.93	1-1/16	26.98	1-1/8	28.58	24.38	21.84	38.86	14.22	49.02	25.91
AMC12-12GB	3/4	19.05	3/4	15.74	1-5/16	33.33	1-1/8	28.58	24.38	21.84	42.67	15.75	52.83	32.00
AMC16-8GB	1	25.40	1/2	11.93	1-3/8	34.92	1-1/2	38.10	31.24	26.41	43.69	14.22	55.88	25.91
AMC16-16GB	1	25.40	1	22.35	1-5/8	41.27	1-1/2	38.10	31.24	26.41	47.75	18.29	59.94	39.12
AMC20-20GB	1-1/4	31.75	1-1/4	27.68	2	50.80	1-7/8	47.63	41.14	38.86	51.16	20.00	73.26	49.00
AMC24-24GB	1-1/2	38.10	1-1/2	34.03	2-1/4	57.15	2-1/4	57.15	50.03	45.21	57.57	22.00	84.75	54.70



## Parallel Pipe Threads – Male

### ISO 228-1

#### Pipe threads where pressure-tight joints are not made on the threads

Either compressing two tightening surfaces (of internal and external threads) outside the threads or by interposing an appropriate gasket seal, the parallel threads make pressure-tight.

Thread Designator: **G**

Thread end form to DIN 3852 Form A  
Sealing by compression of bonded gasket

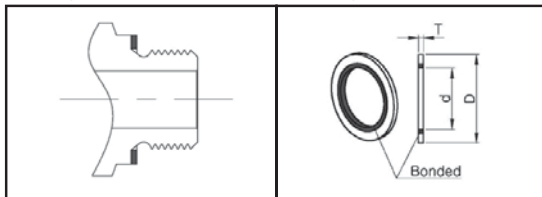

A self-centering taper is constructed at thread end. This taper centers a bonded gasket to seal up on the face of threaded female.

#### Bonded Gasket Ordering Information and Dimensions

G Thread, in.	Dimensions, mm (in.)			Bonded Gasket Part Number	
	D	d	T	A*	B*
1/8	16.0 (0.63)	10.4 (0.41)	2.0 (0.08)	9PBN-2G-C	9PBV-2G-SS
1/4	20.6 (0.81)	13.7 (0.54)		9PBN-4G-C	9PBV-4G-SS
3/8	23.9 (0.94)	17.3 (0.68)		9PBN-6G-C	9PBV-6G-SS
1/2	28.7 (1.13)	21.6 (0.85)	2.5 (0.1)	9PBN-8G-C	9PBV-8G-SS
3/4	35.1 (1.38)	27.2 (1.06)		9PBN-12G-C	9PBV-12G-SS
1	42.9 (1.69)	33.8 (1.33)		9PBN-16G-C	9PBV-16G-SS
1 1/4	51.05 (2.01)	42.4 (1.67)		9PBN-20G-C	9PBV-20G-SS
1 1/2	59.18 (2.33)	48.8 (1.92)		9PBN-24G-C	9PBV-24G-SS

A\*: NBR inner ring bonded to zinc plated carbon steel outer ring.

B\*: FKM inner ring bonded to stainless steel outer ring.

Thread Designator: **GB**

Thread end form to DIN 3852 Form B  
Sealing by compression of copper gasket

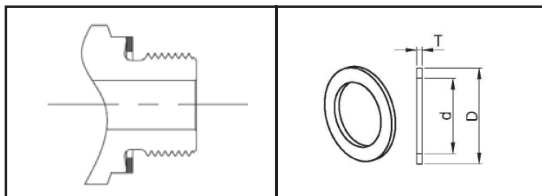

A copper gasket performs sealing between reversed bevel of fitting and the face of threaded female.

#### Copper Gasket Ordering Information and Dimensions

Thread in.	Dimensions, mm (in.)			Part Number
	D	d	T	
1/8	18.0 (0.71)	10.0 (0.39)	2.3 (0.09)	9PP-2G-CU
1/4	22.1 (0.87)	14.0 (0.55)		9PP-4G-CU
3/8	24.0 (0.94)	17.0 (0.67)		9PP-6G-CU
1/2	30.0 (1.18)	22.0 (0.87)		9PP-8G-CU
3/4	35.0 (1.38)	27.0 (1.06)		9PP12G-CU
1	42.0 (1.65)	34.0 (1.34)		9PP-16G-CU
1 1/4	49.8 (1.96)	42.2 (1.66)		9PP-20G-CU
1 1/2	58.4 (2.30)	48.0 (1.89)		9PP-24G-CU

#### Gasket Temperature Ratings

Gasket	Temperature, °F (°C)
Copper	-325 to 400 (-198 to 204)
NBR bonded carbon steel outer ring	-13 to 230 (-25 to 110)
FKM bonded stainless steel outer ring	-20 to 400 (-28 to 204)
Kalrez® bonded stainless steel outer ring	-22 to 600 (-30 to 315)

- Male ISO Parallel Connector  
DIN3852 From B

## AMC-GB

- DIN3852 From A

## AMC-G

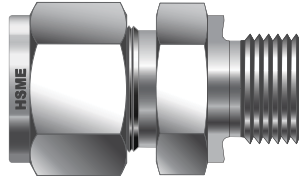
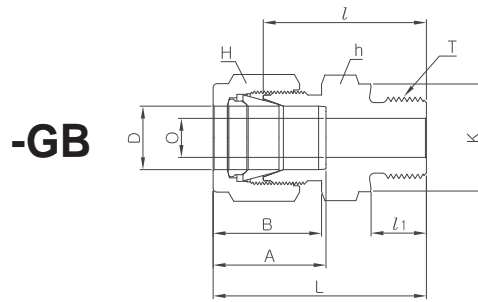
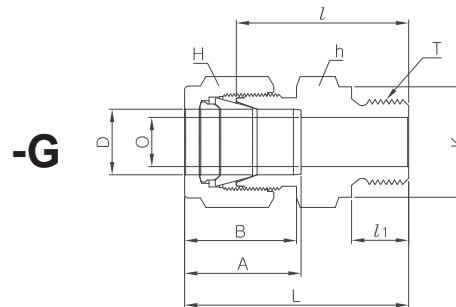

Image Shown  
"GB" End



-GB



-G

Connects metric tube to female ISO parallel thread

Part No.	Tube O.D	T G(PF)	O Min.	Width across flat		A	B	l	T	L	k
				h	H						
AMC3M-2GB(-2G)	3	1/8	2.4	14	12	12.9	15.3	23.4	7.1	30.0	13.8
AMC3M-4GB(-4G)	3	1/4	2.4	19	12	12.9	15.3	28.7	11.2	35.3	18.0
AMC4M-2GB(-2G)	4	1/8	2.4	14	12	13.7	16.1	24.1	7.1	30.7	13.8
AMC4M-4GB(-4G)	4	1/4	2.4	19	12	13.7	16.1	29.4	11.2	36.0	18.0
AMC6M-2GB(-2G)	6	1/8	4.0	14	14	15.3	17.7	24.9	7.1	32.3	13.8
AMC6M-4GB(-4G)	6	1/4	4.8	19	14	15.3	17.7	30.2	11.2	37.6	18.0
AMC6M-6GB(-6G)	6	3/8	4.8	22	14	15.3	17.7	31.5	11.2	38.9	21.8
AMC6M-8GB(-8G)	6	1/2	4.8	27	14	15.3	17.7	37.3	14.2	44.7	26.0
AMC8M-2GB(-2G)	8	1/8	4.0	15	16	16.2	18.6	25.7	7.1	33.2	13.8
AMC8M-4GB(-4G)	8	1/4	6.4	19	16	16.2	18.6	31.0	11.2	38.5	13.8
AMC8M-6GB(-6G)	8	3/8	6.4	22	16	16.2	18.6	32.3	11.2	39.8	21.8
AMC8M-8GB(-8G)	8	1/2	6.4	27	16	16.2	18.6	38.1	14.2	45.6	26.0
AMC10M-4GB(-4G)	10	1/4	6.4	19	19	17.2	19.5	31.8	11.2	39.4	18.0
AMC10M-6GB(-6G)	10	3/8	7.9	22	19	17.2	19.5	33.0	11.2	40.6	21.8
AMC10M-8GB(-8G)	10	1/2	7.9	27	19	17.2	19.5	38.9	14.2	46.5	26.0
AMC12M-4GB(-4G)	12	1/4	5.9	22	22	22.8	22.0	32.5	11.2	42.6	18.0
AMC12M-6GB(-6G)	12	3/8	7.9	22	22	22.8	22.0	33.0	11.2	43.1	21.8
AMC12M-8GB(-8G)	12	1/2	9.5	27	22	22.8	22.0	38.9	14.2	49.0	26.0
AMC12M-12GB(-12G)	12	3/4	9.5	32	22	22.8	22.0	42.7	15.2	52.8	32.0
AMC16M-6GB(-6G)	16	3/8	7.9	24	25	24.4	22.0	33.8	11.2	43.9	21.8
AMC16M-8GB(-8G)	16	1/2	11.9	27	25	24.4	22.0	38.9	14.2	49.0	26.0
AMC18M-8GB(-8G)	18	1/2	11.9	27	30	24.4	22.0	38.9	14.2	49.0	26.0
AMC18M-12GB(-12G)	18	3/4	15.1	35	30	24.4	22.0	42.7	15.7	52.8	32.0
AMC20M-8GB(-8G)	20	1/2	11.9	30	32	26.0	22.0	40.4	14.2	50.5	26.0
AMC20M-12G(-12G)	20	3/4	15.9	35	32	26.0	22.0	42.7	15.7	52.8	32.0
AMC22M-12G(-12G)	22	3/4	15.9	35	32	26.0	22.0	42.7	15.7	52.8	32.0
AMC22M-16G(-16G)	22	1	18.3	41	32	26.0	22.0	45.2	18.3	55.3	39.0
AMC25M-12G(-12G)	25	3/4	15.9	35	38	31.3	26.5	45.2	15.7	57.5	32.0
AMC25M-16G(-16G)	25	1	19.8	41	38	31.3	26.5	47.8	18.3	60.1	39.0
AMC28M-16G(-16G)	28	1	19.8	41	46	36.6	36.6	49.3	18.3	70.1	39.0
AMC28M-20G(-20G)	28	1-1/4	21.8	50	46	36.6	36.6	53.1	19.8	73.9	49.0
AMC32M-20G(-20G)	32	1-1/4	25.0	50	50	42.0	41.6	55.9	19.8	78.9	49.0
AMC38M-24G(-24G)	38	1-1/2	31.8	55	60	49.4	47.9	63.2	22.1	90.8	54.7

• Non-Positionable  
SAE Male Connector  
**AMC-UF**

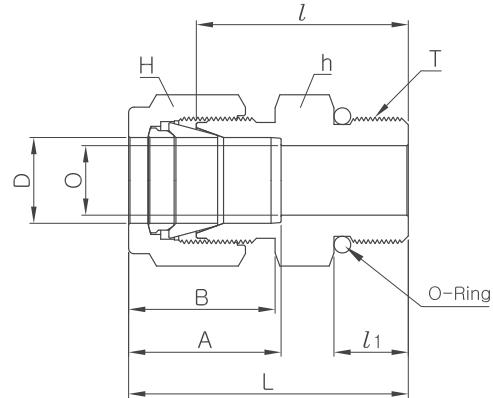
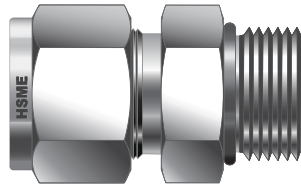

Connects fractional tube to SAE straight thread boss

Part No.	Tube O.D. D		Straight Thread T(U)	O Min.	Width across flat				A	B	l	l1	L	O-Ring Uniform Size Number
	in	mm			h		H							
					in	mm	in	mm						
AMC2-2UF	1/8	3.17	5/16-24	2.28	7/16	11.11	7/16	11.11	12.70	15.24	23.26	7.62	29.97	-902
AMC4-4UF	1/4	6.35	7/16-20	4.82	9/16	14.28	9/16	14.28	15.24	17.78	26.67	9.14	34.03	-904
AMC4-6UF	1/4	6.35	9/16-18	4.82	11/16	17.46	9/16	14.28	15.24	17.78	28.19	9.90	35.56	-906
AMC4-8UF	1/4	6.35	3/4-16	4.82	7/8	22.22	9/16	14.28	15.24	17.78	30.22	11.17	37.59	-908
AMC4-10UF	1/4	6.35	7/8-14	4.82	1	25.40	9/16	14.28	15.24	17.78	33.27	12.70	40.64	-910
AMC5-5UF	5/16	7.93	1/2-20	5.84	5/8	15.87	5/8	15.87	16.25	18.54	27.43	9.14	34.79	-905
AMC6-4UF	3/8	9.52	7/16-20	5.08	5/8	15.87	11/16	17.46	16.76	19.30	28.19	9.14	35.56	-904
AMC6-6UF	3/8	9.52	9/16-18	7.11	11/16	17.46	11/16	17.46	16.76	19.30	29.71	9.90	37.08	-906
AMC6-8UF	3/8	9.52	3/4-16	7.11	7/8	22.22	11/16	17.46	16.76	19.30	31.75	11.17	39.11	-908
AMC6-10UF	3/8	9.52	7/8-14	7.11	1	25.40	11/16	17.46	16.76	19.30	34.79	12.70	42.16	-910
AMC8-6UF	1/2	12.70	9/16-18	7.11	13/16	20.64	7/8	22.22	22.86	21.84	28.95	9.90	39.11	-906
AMC8-8UF	1/2	12.70	3/4-16	10.41	7/8	22.22	7/8	22.22	22.86	21.84	31.75	11.17	41.91	-908
AMC8-10UF	1/2	12.70	7/8-14	10.41	1	25.40	7/8	22.22	22.86	21.84	34.79	12.70	44.95	-910
AMC8-12UF	1/2	12.70	1-1/16-12	10.41	1-1/4	31.75	7/8	22.22	22.86	21.84	38.86	14.98	49.02	-912
AMC10-8UF	5/8	15.87	3/4-16	10.66	15/16	23.81	1	25.40	24.38	21.84	31.75	11.17	41.91	-908
AMC10-10UF	5/8	15.87	7/8-14	12.70	1	25.40	1	25.40	24.38	21.84	35.05	12.70	45.21	-910
AMC12-8UF	3/4	19.05	3/4-16	10.66	1-1/16	26.98	1-1/8	28.57	24.38	21.84	35.81	11.17	45.97	-908
AMC12-12UF	3/4	19.05	1-1/16-12	15.74	1-1/4	31.75	1-1/8	28.57	24.38	21.84	38.86	14.98	49.02	-912
AMC14-14UF	7/8	22.22	1-3/16-12	18.28	1-3/8	34.92	1-1/4	31.75	25.90	21.84	38.86	14.98	49.02	-914
AMC16-12UF	1	25.40	1-1/16-12	16.76	1-3/8	34.92	1-1/2	38.10	31.24	26.41	41.14	14.98	53.54	-912
AMC16-16UF	1	25.40	1-5/16-12	22.35	1-1/2	38.10	1-1/2	38.10	31.24	26.41	42.16	14.98	54.35	-916
AMC20-20UF	1-1/4	31.75	1-5/8-12	27.68	1-7/8	47.63	1-7/8	47.63	41.14	38.86	46.22	14.98	68.32	-920
AMC24-24UF	1-1/4	38.10	1-7/8-12	34.03	2-1/8	53.98	2-1/4	57.15	50.03	45.21	50.54	14.98	77.72	-924
AMC32-32UF	2	50.80	2-1/2-12	45.97	2-3/4	69.85	3	76.20	67.56	62.73	64.26	14.98	101.60	-932

Connects metric tube to SAE straight thread boss

Part No.	Tube O.D. D	Straight Thread T(U)	O Min.	Width across flat		A	B	l	l1	L	O-Ring Uniform Size Number
				h	H						
AMC6M-6UF	6	9/16-18	4.8	18	14	15.3	17.7	28.2	9.90	36.5	-906
AMC10M-6UF	10	9/16-18	7.9	18	19	17.2	19.5	29.7	9.90	37.3	-906
AMC10M-8UF	10	3/4-16	7.9	22	19	17.2	19.5	31.8	11.17	39.4	-908
AMC12M-4UF	12	7/16-20	5.2	22	22	22.8	22.0	28.2	9.14	38.3	-904
AMC12M-6UF	12	9/16-18	7.5	22	22	22.8	22.0	29.0	9.90	39.1	-906

## SAE Straight Thread Mounting to SAE J1926

Thread Designator: **UF**

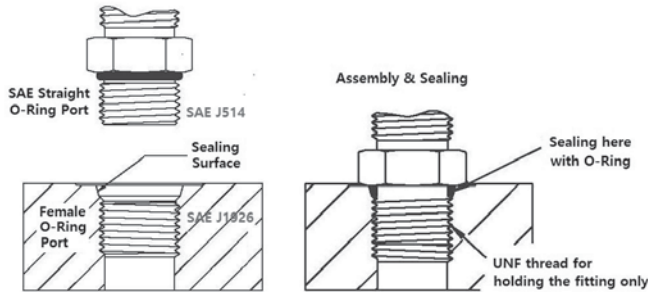

The sealing and holding function are separated in SAE Straight Thread with O-ring.

UNF threads have only the holding function and sealing is achieved with a high durometer O-ring seated in a chamber at the top of the female port.

### Installation Instruction

1. Lubricate the O-ring compatible with system fluid.
2. Finger-tighten the fitting in the port.
3. Hand-tighten the fitting until the O-ring is compressed in the chamber at the top of the female port.
4. Tighten slightly further with wrench to compress the O-ring completely.

## Mounting Dimension for O-Seal Male Connector

**UO:** SAE straight with O-ring in groove

**NO:** NPT thread with O-ring in groove

O-ring is contained in a precision groove that prevents O-ring extrusion at pressure and vacuum.

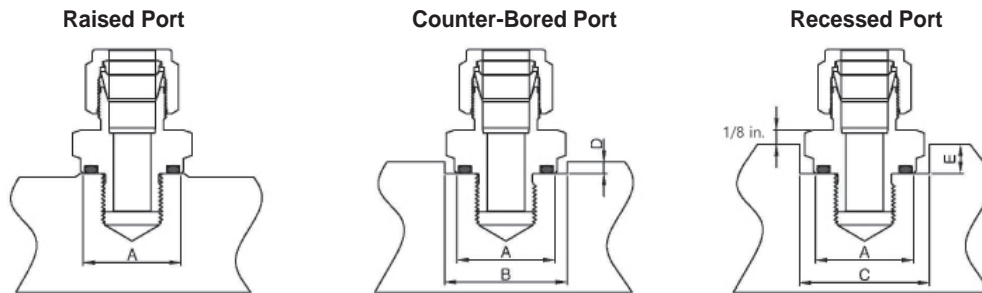

SAE Thread Size	NPT Size	A Min. Flat Dia.	B Min. Clearance Dia.	C Min. Clearance Dia.	D Max Depth	E Max Depth
Dimensions, in.						
5/16-24	-	0.50	0.59	0.66	0.09	0.16
5/16-24	-					0.22
3/8-24	-	0.56	0.66	0.75	0.09	0.22
7/16-20	-	0.69	0.78	0.88	0.16	0.28
1/2-20	-	0.75	0.91	1.03	0.16	0.31
9/16-18	-	0.81	0.97	1.09	0.16	0.31
3/4-16	-	1.00	1.16	1.31	0.16	0.34
11/16-12	-	1.41	1.53	1.75	0.22	0.50
15/16-12	-	1.69	1.78	2.03	0.22	0.56
-	1/8	0.69	0.78	0.88	0.16	0.28
-	1/4	0.87	0.97	1.09	0.16	0.31
-	3/8	1.00	1.16	1.31	0.16	0.34
-	1/2	1.22	1.34	1.53	0.22	0.44

1. **Raised Port**  
The minimum diameter A allows metal-to-metal contact outside of O-ring that prevents O-ring extrusion.
2. **Counter-Bored Port**  
The round shoulder of O-Seal fitting is recessed into counter-bored port.
3. **Recessed Port**  
The Hex of O-Seal fitting is recessed into the recessed port.

• Port should have a smooth, flat surface perpendicular to the port. NPT thread in short length ensures thread interference.

### Installation Instruction

1. Lubricate the O-ring compatible with system fluid.
2. Finger-tighten the O-Seal fitting in the port.
3. Hand-tighten the fitting until squeezing of O-ring is felt during the last 1/4 turn.
4. Gently wrench-tighten the fitting until the round shoulder outside of O-ring achieves metal-to-metal contact against the flat face of female port. This compresses O-ring completely for leak-tight.

• O-Seal SAE  
Male Connector  
**AMC-UO**

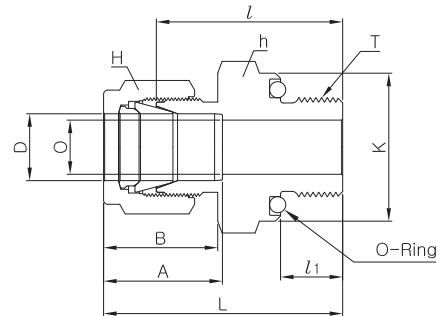
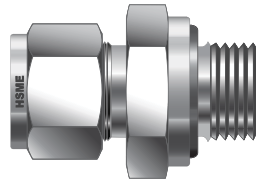

Connects fractional tube to female SAE straight thread

Part No.	Tube O.D. D		Straight Thread T(U)	O Min.	Width across flat				A	B	l	l1	L	O-Ring Uniform Size Number
	in	mm			h		H							
					in	mm	in	mm						
AMC 2-2UO	1/8	3.17	5/16-24	2.28	9/16	14.28	7/16	11.11	12.70	15.24	26.16	8.63	32.76	-011
AMC 3-3UO	3/16	4.76	3/8-24	3.04	5/8	15.87	1/2	12.70	13.71	16.00	27.68	9.65	34.29	-012
AMC 4-4UO	1/4	6.35	7/16-20	4.82	3/4	19.05	9/16	14.28	15.24	17.78	30.98	10.41	38.35	-013
AMC 5-5UO	5/16	7.93	1/2-20	6.35	7/8	22.22	5/8	15.87	16.25	18.54	33.27	11.17	40.64	-112
AMC 6-6UO	3/8	9.52	9/16-18	7.11	15/16	23.81	11/16	17.46	16.76	19.30	35.05	11.93	42.41	-113
AMC 8-8UO	1/2	12.70	3/4-16	10.41	1-1/8	28.57	7/8	22.22	22.86	21.84	35.81	11.93	45.97	-116
AMC 12-12UO	3/4	19.05	1-1/16-12	15.74	1-1/2	38.10	1-1/8	28.58	24.38	21.84	42.16	14.22	52.32	-121
AMC 16-16UO	1	25.40	1-5/16-12	22.35	1-3/4	44.45	1-1/2	38.10	31.24	26.41	45.97	14.22	58.16	-125

• O-Seal NPT  
Male Connector  
**AMC-NO**

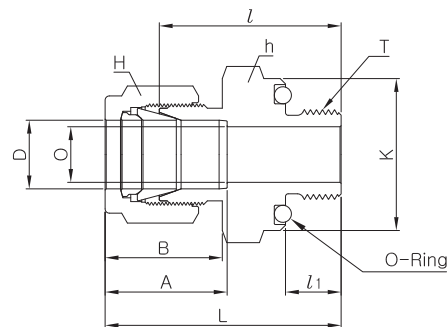
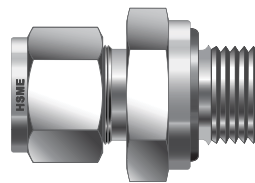

Connects fractional tube to female NPT thread

Part No.	Tube O.D. D		T (NPT)	O Min.	Width across flat				A	B	l	l1	L	O-Ring Uniform Size Number
	in	mm			h		H							
					in	mm	in	mm						
AMC 2-2NO	1/8	3.17	1/8	2.28	3/4	19.05	7/16	11.11	12.70	15.24	26.16	7.11	32.76	-013
AMC 4-2NO	1/4	6.35	1/8	4.82	3/4	19.05	9/16	14.28	15.24	17.78	27.68	7.11	35.05	-013
AMC 4-4NO	1/4	6.35	1/4	4.82	15/16	23.81	9/16	14.28	15.24	17.78	30.98	9.65	38.35	-113
AMC 6-4NO	3/8	9.52	1/4	7.11	15/16	23.81	11/16	17.46	16.76	19.30	32.51	9.65	39.87	-113
AMC 6-6NO	3/8	9.52	3/8	7.11	1-1/8	28.58	11/16	17.46	16.76	19.30	34.03	10.41	41.40	-116
AMC 6-8NO	3/8	9.52	1/2	7.11	1-5/16	33.33	11/16	17.46	16.76	19.30	39.62	13.46	46.99	-118
AMC 8-8NO	1/2	12.70	1/2	10.41	1-5/16	33.33	7/8	22.22	22.86	21.84	39.62	13.46	49.78	-118

# M Tube Fittings®

## 45° Male NPT Elbow ALBM-N

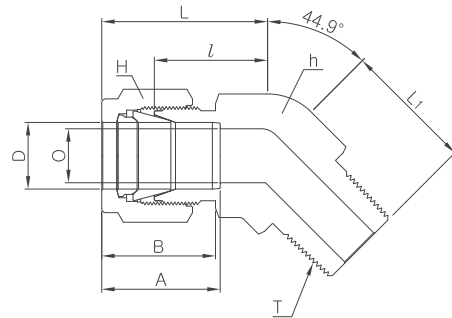
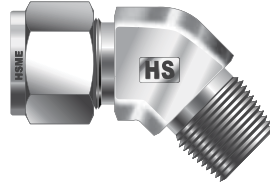

Connects fractional tube to female NPT thread

Part No.	Tube O.D. D		T NPT	O Min.	Width across flat				A	B	/	L	L1
	in	mm			h		H						
					in	mm	in	mm					
ALBM 2-2N	1/8	3.17	1/8	2.4	1/2	12.70	7/16	11.11	12.70	15.24	15.77	22.38	16.51
ALBM 4-2N	1/4	6.35	1/8	4.82	1/2	12.70	9/16	14.28	15.24	17.78	17.27	24.63	16.51
ALBM 4-4N	1/4	6.35	1/4	4.82	1/2	12.70	9/16	14.28	15.24	17.78	17.27	24.63	21.08
ALBM 6-2N	3/8	9.52	1/8	4.82	5/8	15.87	11/16	17.46	16.76	19.30	20.57	27.94	18.28
ALBM 6-4N	3/8	9.52	1/4	7.11	5/8	15.87	11/16	17.46	16.76	19.30	20.57	27.94	22.86
ALBM 6-6N	3/8	9.52	3/8	7.11	13/16	20.64	11/16	17.46	16.76	19.30	21.84	29.21	24.13
ALBM 8-6N	1/2	12.70	3/8	9.65	13/16	20.64	7/8	22.22	22.86	21.84	21.84	32.00	24.13
ALBM 8-8N	1/2	12.70	1/2	10.41	13/16	20.64	7/8	22.22	22.86	21.84	21.84	32.00	28.95
ALBM 12-12N	3/4	19.05	3/4	15.74	1-1/8	28.58	1-1/8	28.58	24.38	21.84	23.87	34.03	30.98
ALBM 16-16N	1	25.40	1	22.35	1-3/8	34.93	1-1/2	38.10	31.24	26.41	28.19	40.38	37.84

Connects metric tube to female NPT thread

Part No.	Tube O.D. D	T NPT	O Min.	Width across flat		A	B	/	L	L1
				h	H					
ALBM 6M-4N	6	1/4	4.8	12.7	14.0	15.3	17.7	21.8	29.4	22.9
ALBM 12M-8N	12	1/2	9.5	20.64	22.0	22.8	22.0	21.8	31.9	29.0

## Positionable 45° SAE Male Elbow ALBS-UP

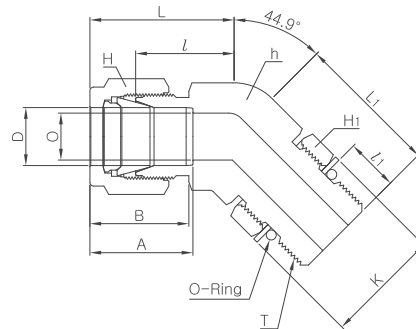
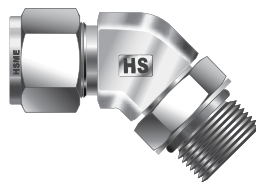

Connects fractional tube to SAE straight thread boss

Part No.	Tube O.D. D		Straight Thread T(U)	O Min.	Width across flat						A	B	/	/1	L	L1	K	O-Ring Uniform Size Number
	in	mm			h		H		H1									
					in	mm	in	mm	in	mm								
ALBS 4-4UP	1/4	6.35	7/16-20	4.82	1/2	12.70	9/16	14.28	9/16	14.28	15.24	17.78	18.28	9.90	25.65	25.65	16.51	-904
ALBS 6-6UP	3/8	9.52	9/16-18	7.11	5/8	15.87	11/16	17.46	11/16	17.46	16.76	19.30	20.57	11.17	27.94	28.19	20.06	-906
ALBS 8-8UP	1/2	12.70	3/4-16	10.41	13/16	20.64	7/8	22.22	7/8	22.22	22.86	21.84	21.84	12.70	32.00	32.25	25.65	-908
ALBS12-12UP	3/4	19.05	1-1/16-12	15.74	1-1/8	28.58	1-1/8	28.58	1-1/4	31.75	24.38	21.84	29.71	16.76	39.87	47.24	36.57	-912
ALBS16-16UP	1	25.40	1-5/16-12	22.35	1-3/8	34.92	1-1/2	38.10	1-1/2	38.10	31.24	26.41	35.30	16.76	47.49	50.54	43.94	-916

Male NPT Elbow  
**ALM-N**

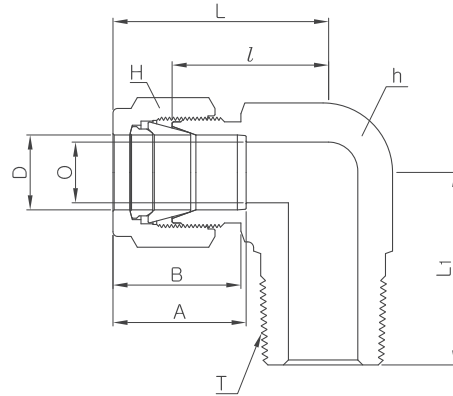
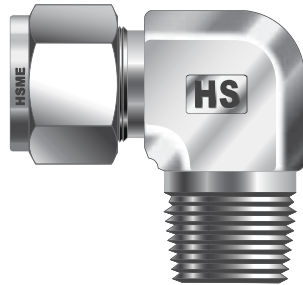

Connects fractional tube to female NPT thread

Part No.	Tube O.D. D		T NPT	O Min.	Width across flat				A	B	/	L	L1
	in	mm			h		H						
					in	mm	in	mm					
ALM1-1N	1/16	1.59	1/16	1.27	7/16	11.11	5/16	7.93	8.63	10.92	15.24	19.05	17.78
ALM1-2N	1/16	1.59	1/8	1.27	7/16	11.11	5/16	7.93	8.63	10.92	15.24	19.05	17.78
ALM2-2N	1/8	3.17	1/8	2.28	1/2	12.70	7/16	11.11	12.70	15.24	18.30	24.91	18.90
ALM2-4N	1/8	3.17	1/4	2.28	1/2	12.70	7/16	11.11	12.70	15.24	18.30	24.91	23.26
ALM3-2N	3/16	4.76	1/8	3.04	1/2	12.70	1/2	12.70	13.71	16.00	18.79	25.40	18.79
ALM3-4N	3/16	4.76	1/4	3.04	1/2	12.70	1/2	12.70	13.71	16.00	18.79	25.40	23.36
ALM4-1N	1/4	6.35	1/16	3.04	1/2	12.70	9/16	14.28	15.24	17.78	19.55	26.90	18.79
ALM4-2N	1/4	6.35	1/8	4.82	1/2	12.70	9/16	14.28	15.24	17.78	19.55	26.47	18.79
ALM4-4N	1/4	6.35	1/4	4.82	1/2	12.70	9/16	14.28	15.24	17.78	19.81	27.18	23.87
ALM4-6N	1/4	6.35	3/8	4.82	11/16	17.46	9/16	14.28	15.24	17.78	22.35	29.71	26.20
ALM4-8N	1/4	6.35	1/2	4.82	13/16	20.64	9/16	14.28	15.24	17.78	24.60	31.97	33.02
ALM5-2N	5/16	7.93	1/8	4.82	9/16	14.28	5/8	15.87	16.25	18.54	21.33	28.70	19.81
ALM5-4N	5/16	7.93	1/4	6.35	9/16	14.28	5/8	15.87	16.25	18.54	21.33	29.77	24.50
ALM5-6N	5/16	7.93	3/8	6.35	11/16	17.46	5/8	15.87	16.25	18.54	23.11	30.48	26.20
ALM6-2N	3/8	9.52	1/8	4.82	5/8	15.87	11/16	17.46	16.76	19.30	23.11	30.48	20.60
ALM6-4N	3/8	9.52	1/4	7.11	5/8	15.87	11/16	17.46	16.76	19.30	23.11	30.48	25.40
ALM6-6N	3/8	9.52	3/8	7.11	11/16	17.46	11/16	17.46	16.76	19.30	23.87	31.24	26.20
ALM6-8N	3/8	9.52	1/2	7.11	13/16	20.64	11/16	17.46	16.76	19.30	25.90	31.42	33.02
ALM6-12N	3/8	9.52	3/4	7.11	1-1/16	26.98	11/16	17.46	16.76	19.30	29.71	37.08	36.83
ALM8-4N	1/2	12.70	1/4	7.11	13/16	20.64	7/8	22.22	22.86	21.84	25.90	36.06	28.30
ALM8-6N	1/2	12.70	3/8	9.65	13/16	20.64	7/8	22.22	22.86	21.84	25.90	36.06	28.30
ALM8-8N	1/2	12.70	1/2	10.41	13/16	20.64	7/8	22.22	22.86	21.84	25.90	36.06	33.02
ALM8-12N	1/2	12.70	3/4	10.41	1-1/16	26.98	7/8	22.22	22.86	21.84	29.71	39.87	36.83
ALM10-6N	5/8	15.87	3/8	9.65	15/16	23.81	1	25.40	24.38	21.84	28.00	37.06	30.22
ALM10-8N	5/8	15.87	1/2	11.93	15/16	23.81	1	25.40	24.38	21.84	28.00	37.06	35.10
ALM10-12N	5/8	15.87	3/4	12.70	1-1/16	26.98	1	25.40	24.38	21.84	29.71	39.87	36.83
ALM12-8N	3/4	19.05	1/2	11.93	1-1/16	26.98	1-1/8	28.57	24.38	21.84	29.71	39.87	37.00
ALM12-12N	3/4	19.05	3/4	15.74	1-1/16	26.98	1-1/8	28.57	24.38	21.84	29.71	39.87	36.83
ALM14-12N	7/8	22.22	3/4	15.74	1-3/8	34.92	1-1/4	31.75	25.90	21.84	34.54	44.70	41.65
ALM16-12N	1	25.40	3/4	15.74	1-3/8	34.92	1-1/2	38.10	31.24	26.41	36.83	49.02	42.20
ALM16-16N	1	25.40	1	22.35	1-3/8	34.92	1-1/2	38.10	31.24	26.41	36.83	49.02	46.70
ALM20-20N	1-1/4	31.75	1-1/4	27.68	1-11/16	42.86	1-7/8	47.63	41.14	38.86	44.50	66.54	47.75
ALM24-24N	1-1/2	38.10	1-1/2	34.03	2	50.80	2-1/4	57.15	50.03	45.21	50.80	77.97	60.45
ALM32-32N	2	50.80	2	45.97	2-3/4	69.85	3	76.20	62.73	63.73	69.80	107.18	70.61

• Male NPT Elbow  
**ALM-N**

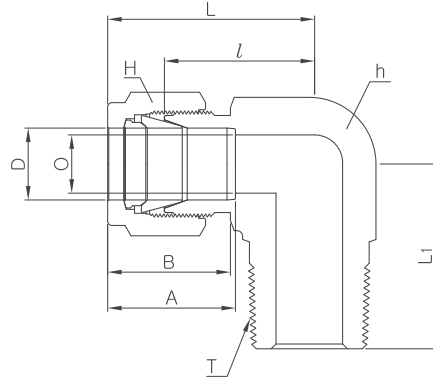
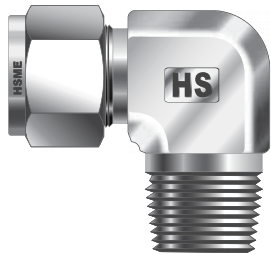

Connects metric tube to female NPT thread

Part No.	Tube O.D. D	T R(PT)	O Min.	Width across flat		A	B	l	L	L1
				h	H					
ALM3M-1N	3	1/16	2.4	11.1	12	12.9	15.3	17.0	23.6	17.8
ALM3M-2N	3	1/8	2.4	12.7	12	12.9	15.3	17.0	23.6	17.8
ALM3M-4N	3	1/4	2.4	12.7	12	12.9	15.3	18.0	24.6	23.4
ALM4M-2N	4	1/8	2.4	12.7	12	13.7	16.1	18.8	25.4	18.8
ALM4M-4N	4	1/4	2.4	12.7	12	13.7	16.1	18.8	25.4	23.4
ALM6M-2N	6	1/8	4.8	12.7	14	15.3	17.7	19.6	27.0	18.8
ALM6M-4N	6	1/4	4.8	12.7	14	15.3	17.7	19.6	27.0	23.4
ALM6M-6N	6	3/8	4.8	17.5	14	15.3	17.7	22.4	29.8	26.2
ALM6M-8N	6	1/2	4.8	20.6	14	15.3	17.7	24.4	31.8	33.0
ALM8M-2N	8	1/8	4.8	14.3	16	16.2	18.6	21.3	28.8	19.8
ALM8M-4N	8	1/4	6.4	14.3	16	16.2	18.6	21.3	28.8	24.4
ALM8M-6N	8	3/8	6.4	17.5	16	16.2	18.6	23.1	30.6	26.2
ALM8M-8N	8	1/2	6.4	20.6	16	16.2	18.6	25.1	32.6	33.0
ALM10M-2N	10	1/8	4.8	17.5	19	17.2	19.5	23.9	31.5	23.6
ALM10M-4N	10	1/4	7.1	17.5	19	17.2	19.5	23.9	31.5	26.2
ALM10M-6N	10	3/8	7.9	17.5	19	17.2	19.5	23.9	31.5	26.2
ALM10M-8N	10	1/2	7.9	20.6	19	17.2	19.5	25.9	33.5	33.0
ALM12M-2N	12	1/8	4.8	20.6	22	22.8	22.0	25.9	36.0	23.6
ALM12M-4N	12	1/4	7.1	20.6	22	22.8	22.0	25.9	36.0	28.2
ALM12M-6N	12	3/8	9.5	20.6	22	22.8	22.0	25.9	36.0	28.2
ALM12M-8N	12	1/2	9.5	20.6	22	22.8	22.0	25.9	36.0	33.0
ALM12M-12N	12	3/4	9.5	27.0	22	22.8	22.0	29.7	39.8	36.8
ALM16M-6N	16	3/8	9.5	25.4	25	24.4	22.0	27.9	38.0	30.2
ALM16M-8N	16	1/2	11.9	23.81	25	24.4	22.0	27.9	38.0	35.1
ALM16M-12N	16	3/4	12.7	23.81	25	24.4	22.0	29.7	39.8	36.8
ALM18M-8N	18	1/2	11.9	27.0	30	24.4	22.0	29.7	39.8	36.8
ALM18M-12N	18	3/4	15.1	27.0	30	24.4	22.0	29.7	39.8	36.8
ALM20M-8N	20	1/2	11.9	34.92	32	26.0	22.0	34.5	44.6	41.7
ALM20M-12N	20	3/4	15.9	34.92	32	26.0	22.0	34.5	44.6	41.7
ALM22M-12N	22	3/4	15.9	34.92	32	26.0	22.0	34.5	44.6	41.7
ALM22M-16N	22	1	18.3	34.92	32	26.0	22.0	34.5	44.6	46.5
ALM25M-12N	25	3/4	15.9	34.92	38	31.3	26.5	36.8	49.1	41.7
ALM25M-16N	25	1	21.8	34.92	38	31.3	26.5	36.8	49.1	46.5
ALM28M-16N	28	1	21.8	41.0	46	36.6	36.6	43.2	64.0	53.7
ALM30M-20N	30	1-1/4	26.2	46.0	50	39.6	39.2	48.3	69.9	53.1
ALM32M-20N	32	1-1/4	27.8	46.0	50	42.0	41.6	49.3	72.3	53.1
ALM38M-24N	38	1-1/4	33.7	50.8	60	49.4	47.9	56.4	84.0	60.4



• Male BSPT Elbow  
**ALM-R**

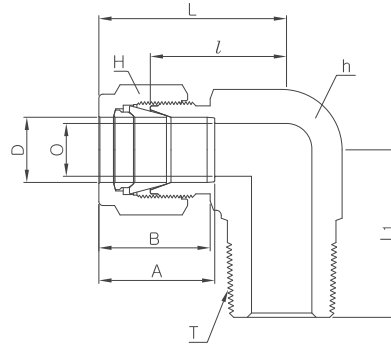
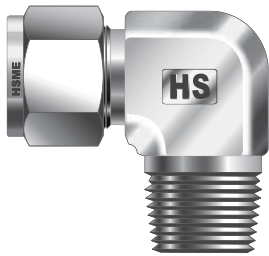

Connects fractional tube to female ISO tapered thread

Part No.	Tube O.D. D		T PT	O Min.	Width across flat				A	B	/	L	L1
	in	mm			h		H						
					in	mm	in	mm					
ALM 2-2R	1/8	3.17	1/8	2.28	1/2	12.70	7/16	11.11	12.70	15.24	18.30	24.91	18.90
ALM2-4R	1/8	3.17	1/4	2.28	1/2	12.70	7/16	11.11	12.70	15.24	18.30	24.91	23.26
ALM3-4R	3/16	4.76	1/4	3.04	1/2	12.70	1/2	12.70	13.71	16.00	18.79	25.40	23.36
ALM4-2R	1/4	6.35	1/8	4.82	1/2	12.70	9/16	14.28	15.24	17.78	19.55	26.47	18.79
ALM4-4R	1/4	6.35	1/4	4.82	1/2	12.70	9/16	14.28	15.24	17.78	19.81	27.18	23.87
ALM4-6R	1/4	6.35	3/8	4.82	11/16	17.46	9/16	14.28	15.24	17.78	22.35	29.71	26.20
ALM4-8R	1/4	6.35	1/2	4.82	13/16	20.64	9/16	14.28	15.24	17.78	24.60	31.97	33.02
ALM5-4R	5/16	7.93	1/4	6.35	9/16	14.28	5/8	15.87	16.25	18.54	21.33	29.77	24.50
ALM5-6R	5/16	7.93	3/8	6.35	11/16	17.46	5/8	15.87	16.25	18.54	23.11	30.48	26.20
ALM6-2R	3/8	9.52	1/8	4.82	5/8	15.87	11/16	17.46	16.76	19.30	23.11	30.48	20.60
ALM6-4R	3/8	9.52	1/4	7.11	5/8	15.87	11/16	17.46	16.76	19.30	23.11	30.48	25.40
ALM6-6R	3/8	9.52	3/8	7.11	11/16	17.46	11/16	17.46	16.76	19.30	23.87	31.24	26.20
ALM6-8R	3/8	9.52	1/2	7.11	13/16	20.64	11/16	17.46	16.76	19.30	25.90	31.42	33.02
ALM6-12R	3/8	9.52	3/4	7.11	1-1/16	26.98	11/16	17.46	16.76	19.30	29.71	37.08	36.83
ALM8-4R	1/2	12.70	1/4	7.11	13/16	20.64	7/8	22.22	22.86	21.84	25.90	36.06	28.30
ALM8-6R	1/2	12.70	3/8	9.65	13/16	20.64	7/8	22.22	22.86	21.84	25.90	36.06	28.30
ALM8-8R	1/2	12.70	1/2	10.41	13/16	20.64	7/8	22.22	22.86	21.84	25.90	36.06	33.02
ALM8-12R	1/2	12.70	3/4	10.41	1-1/16	26.98	7/8	22.22	22.86	21.84	29.71	39.87	36.83
ALM10-6R	5/8	15.87	3/8	9.65	15/16	23.81	1	25.40	24.38	21.84	28.00	37.06	30.22
ALM10-8R	5/8	15.87	1/2	11.93	15/16	23.81	1	25.40	24.38	21.84	28.00	37.06	35.10
ALM10-12R	5/8	15.87	3/4	12.70	1-1/16	26.98	1	25.40	24.38	21.84	29.71	39.87	36.83
ALM12-8R	3/4	19.05	1/2	11.93	1-1/16	26.98	1-1/8	28.57	24.38	21.84	29.71	39.87	37.00
ALM12-12R	3/4	19.05	3/4	15.74	1-1/16	26.98	1-1/8	28.57	24.38	21.84	29.71	39.87	36.83
ALM12-16R	3/4	19.05	1	16.0	1-3/8	34.92	1-1/8	28.57	24.38	21.84	34.54	44.59	46.48
ALM16-12R	1	25.40	3/4	15.74	1-3/8	34.92	1-1/2	38.10	31.24	26.41	36.83	49.02	42.20
ALM16-16R	1	25.40	1	22.35	1-3/8	34.92	1-1/2	38.10	31.24	26.41	36.83	49.02	46.70
ALM20-12R	1-1/4	31.75	3/4	15.74	1-11/16	42.86	1-7/8	47.63	41.14	38.86	44.50	66.54	42.95
ALM20-20R	1-1/4	31.75	1-1/4	27.68	1-11/16	42.86	1-7/8	47.63	41.14	38.86	44.50	66.54	47.75

## Male BSPT Elbow ALM-R

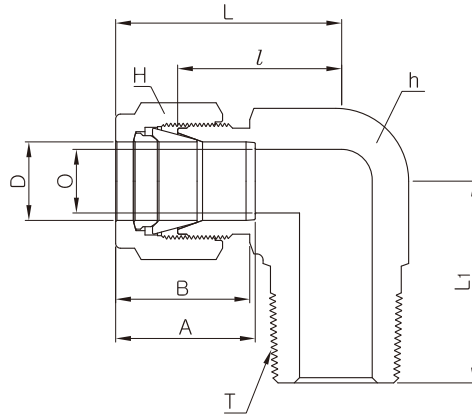
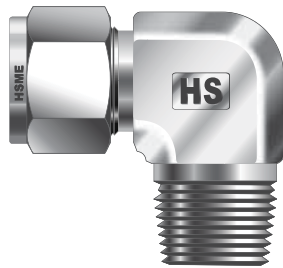

Connects metric tube to female ISO tapered thread

Part No.	Tube O.D. D	T R(PT)	O Min.	Width Across flat		A	B	/	L	L1
				h	H					
ALM3M-1R	3	1/16	2.4	11.1	12	12.9	15.3	17.0	23.6	17.8
ALM3M-2R	3	1/8	2.4	12.7	12	12.9	15.3	17.0	23.6	17.8
ALM3M-4R	3	1/4	2.4	12.7	12	12.9	15.3	18.0	24.6	23.4
ALM4M-2R	4	1/8	2.4	12.7	12	13.7	16.1	18.8	25.4	18.8
ALM4M-4R	4	1/4	2.4	12.7	12	13.7	16.1	18.8	25.4	23.4
ALM6M-2R	6	1/8	4.8	12.7	14	15.3	17.7	19.6	27.0	18.8
ALM6M-4R	6	1/4	4.8	12.7	14	15.3	17.7	19.6	27.0	23.4
ALM6M-6R	6	3/8	4.8	17.5	14	15.3	17.7	22.4	29.8	26.2
ALM6M-8R	6	1/2	4.8	20.6	14	15.3	17.7	24.4	31.8	33.0
ALM8M-2R	8	1/8	4.8	14.3	16	16.2	18.6	21.3	28.8	19.8
ALM8M-4R	8	1/4	6.4	14.3	16	16.2	18.6	21.3	28.8	24.4
ALM8M-6R	8	3/8	6.4	17.5	16	16.2	18.6	23.1	30.6	26.2
ALM8M-8R	8	1/2	6.4	20.6	16	16.2	18.6	25.1	32.6	33.0
ALM10M-2R	10	1/8	4.8	17.5	19	17.2	19.5	23.9	31.5	23.6
ALM10M-4R	10	1/4	7.1	17.5	19	17.2	19.5	23.9	31.5	26.2
ALM10M-6R	10	3/8	7.9	17.5	19	17.2	19.5	23.9	31.5	26.2
ALM10M-8R	10	1/2	7.9	20.6	19	17.2	19.5	25.9	33.5	33.0
ALM12M-2R	12	1/8	4.8	20.6	22	22.8	22.0	25.9	36.0	23.6
ALM12M-4R	12	1/4	7.1	20.6	22	22.8	22.0	25.9	36.0	28.2
ALM12M-6R	12	3/8	9.5	20.6	22	22.8	22.0	25.9	36.0	28.2
ALM12M-8R	12	1/2	9.5	20.6	22	22.8	22.0	25.9	36.0	33.0
ALM12M-12R	12	3/4	9.5	27.0	22	22.8	22.0	29.7	39.8	36.8
ALM14M-8R	14	1/2	11.1	23.81	25	24.4	22.0	27.9	38.0	30.2
ALM15M-6R	15	3/8	9.5	23.81	25	24.4	22.0	27.9	38.0	30.2
ALM15M-8R	15	1/2	11.9	23.81	25	24.4	22.0	27.9	38.0	35.1
ALM16M-6R	16	3/8	9.5	25.4	25	24.4	22.0	27.9	38.0	30.2
ALM16M-8R	16	1/2	11.9	23.81	25	24.4	22.0	27.9	38.0	35.1
ALM18M-8R	18	1/2	11.9	27.0	30	24.4	22.0	29.7	39.8	36.8
ALM18M-12R	18	3/4	15.1	27.0	30	24.4	22.0	29.7	39.8	36.8
ALM20M-8R	20	1/2	11.9	34.92	32	26.0	22.0	34.5	44.6	41.7
ALM20M-12R	20	3/4	15.9	34.92	32	26.0	22.0	34.5	44.6	41.7
ALM22M-8R	22	1/2	11.9	34.92	32	26.0	22.0	32.5	42.6	39.6
ALM22M-12R	22	3/4	15.9	34.92	32	26.0	22.0	34.5	44.6	41.7
ALM22M-16R	22	1	18.3	34.92	32	26.0	22.0	34.5	44.6	46.5
ALM25M-8R	25	1/2	11.9	34.92	38	31.3	26.5	36.8	49.1	41.7
ALM25M-12R	25	3/4	15.9	34.92	38	31.3	26.5	36.8	49.1	41.7
ALM25M-16R	25	1	21.8	34.92	38	31.3	26.5	36.8	49.1	46.5
ALM28M-16R	28	1	21.8	41.0	46	36.6	36.6	43.2	64.0	53.7

Positionable  
Male ISO Parallel  
Thread Elbow  
**ALM-GR**

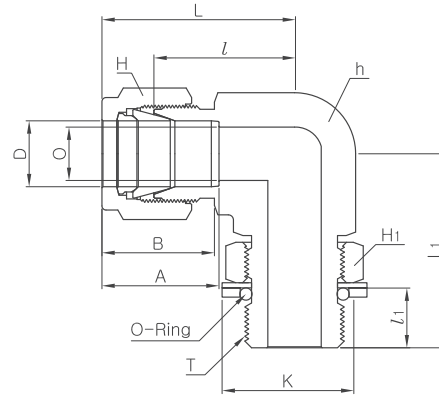
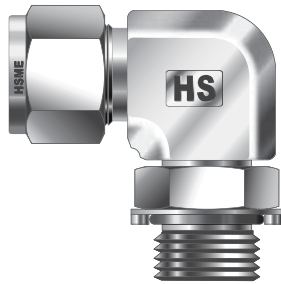

Connects fractional tube to ISO parallel thread

Part No.	Tube O.D. D		T G(PF)	O Min.	Width across flat						A	B	/	/1	L	L1	K	O-Ring Uniform Size Number
	in	mm			h		H		H1									
					in	mm	in	mm	in	mm								
ALM4-2GR	1/4	6.35	1/8	4.06	1/2	12.70	9/16	14.28	9/16	14.28	15.24	17.78	19.6	8.12	26.92	26.42	15.20	P8
ALM4-4GR	1/4	6.35	1/4	4.82	5/8	15.87	11/16	17.46	3/4	19.05	15.24	17.78	21.6	9.14	28.95	32.30	20.30	-111
ALM6-4GR	3/8	9.52	1/4	5.84	5/8	15.87	11/16	17.46	3/4	19.05	16.76	19.30	23.1	9.14	30.48	32.30	20.30	-111
ALM6-6GR	3/8	9.52	3/8	7.11	13/16	20.64	11/16	17.46	3/4	19.05	16.76	19.30	25.9	9.39	33.27	37.10	24.40	-113
ALM8-8GR	1/2	12.70	1/4	5.84	13/16	20.64	7/8	22.22	7/8	22.22	22.86	21.84	25.9	9.14	36.06	35.10	20.30	-111
ALM8-8GR	1/2	12.70	3/8	7.87	13/16	20.64	7/8	22.22	7/8	22.22	22.86	21.84	25.9	9.39	36.06	37.10	24.40	-113
ALM8-8GR	1/2	12.70	1/2	10.41	15/16	23.81	7/8	22.22	1-1/16	26.98	22.86	21.84	27.9	12.95	38.10	43.40	29.50	P18
ALM12-8GR	3/4	19.05	1/2	11.93	1-1/16	26.98	1-1/8	28.57	1-1/16	26.98	24.38	21.84	29.7	12.95	39.87	45.21	29.50	P18
ALM12-12GR	3/4	19.05	3/4	15.74	1-1/16	26.93	1-1/8	28.57	1-3/8	34.92	24.38	21.84	29.7	12.95	39.87	48.77	36.30	-119
ALM16-16GR	1	25.40	1	19.81	1-3/8	34.92	1-1/2	38.10	1-3/8	41.28	31.24	26.41	36.8	13.97	49.02	53.60	46.20	-217

Connects metric tube to ISO parallel thread

Part No.	Tube O.D. D	T G(PF)	O Min.	Width across flat			A	B	/	/1	L	L1	K	O-Ring Uniform Size Number
				h	H	H1								
				ALM6M-2GR	6	1/8								
ALM6M-4GR	6	1/4	4.8	15.8	14	19.05	15.3	17.7	21.6	9.1	29.0	32.3	20.30	-111
ALM6M-6GR	6	3/8	4.8	20.6	14	22.22	15.3	17.7	24.4	9.4	31.8	37.1	24.40	-113
ALM8M-2GR	8	1/8	4.0	14.2	16	14.28	16.2	18.6	21.3	8.1	28.8	27.4	15.20	P8
ALM8M-4GR	8	1/4	5.9	15.8	16	19.05	16.2	18.6	22.4	9.1	29.9	32.2	20.30	-111
ALM10M-4GR	10	1/4	5.9	20.6	19	19.05	17.2	19.5	25.9	9.1	33.5	35.0	20.30	-113
ALM10M-6GR	10	3/8	7.9	20.6	19	22.22	17.2	19.5	25.9	9.4	33.5	37.1	24.40	-111
ALM12M-4GR	12	1/4	5.9	20.6	22	19.05	22.8	22.0	25.9	9.1	36.0	35.0	20.30	-113
ALM12M-6GR	12	3/8	7.9	20.6	22	22.22	22.8	22.0	25.9	9.4	36.0	37.1	24.40	-113
ALM12M-8GR	12	1/2	9.5	23.8	22	26.98	22.8	22.0	27.9	13.0	38.0	43.4	29.50	P18

## Installation Instruction for Positionable Fittings

### Thread Designator "GR" - ISO parallel pipe thread with O-ring

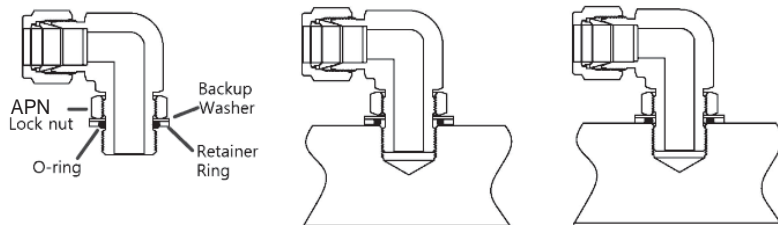

1. Lubricate O-ring compatible with system fluid.
2. Slip retainer ring over the O-ring.
3. Screw fitting in the port until retainer ring bottoms.
4. To adjust direction, turn the fitting back to a maximum of one full turn.
5. Position the direction and hand-tighten locknut.
6. Holding the fitting in the desired direction and wrench-tight the locknut.

### Thread Designator "UP"-Unified thread with O-ring

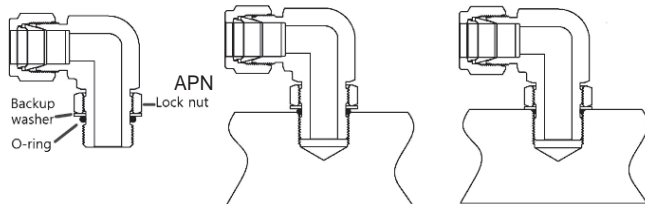

1. Lubricate O-ring compatible with system fluid.
2. Move back locknut to a maximum position.
3. Screw fitting in the port until O-ring is compressed in the chamber at the top of the port.
4. To adjust direction, turn the fitting back to a maximum of one full turn.
5. Position the direction and hand-tighten locknut.
6. Hold the fitting in the desired direction and wrench-tighten the locknut until washer contacts the face of the port.

### Positionable SAE Male Elbow ALS-UP

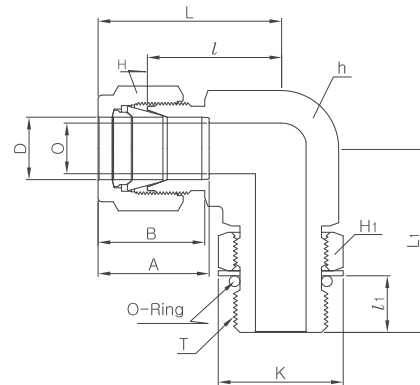
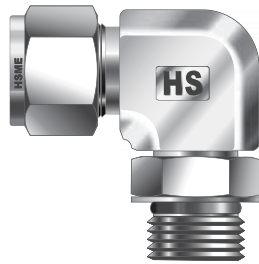

Connects fractional tube to SAE straight thread boss

Part No.	Tube O.D. D		Straight Thread T(U)	O Min.	Width across flat						A	B	I	I1	L	L1	K	O-Ring Uniform Size Number
	in	mm			h		H		H1									
					in	mm	in	mm	in	mm								
ALS 4-4UP	1/4	6.35	7/16-20	4.82	1/2	12.70	9/16	14.28	9/16	14.28	15.24	17.78	21.08	9.90	28.44	28.44	16.51	-904
ALS 5-5UP	5/16	7.93	1/2-20	5.84	9/16	14.28	5/8	15.87	5/8	15.87	16.25	18.54	22.86	9.90	30.22	29.46	18.28	-905
ALS 6-6UP	3/8	9.52	9/16-18	7.11	5/8	15.87	11/16	17.46	11/16	17.46	16.76	19.30	24.63	11.17	32.00	32.25	20.06	-906
ALS 6-8UP	3/8	9.52	3/4-16	7.11	13/16	20.64	11/16	17.46	7/8	22.22	16.76	19.30	27.43	12.70	34.79	37.84	25.65	-908
ALS 8-8UP	1/2	12.70	3/4-16	10.41	13/16	20.64	7/8	22.22	7/8	22.22	22.86	21.84	27.43	12.70	37.59	37.84	25.65	-908
ALS 10-10UP	5/8	15.87	7/8-14	12.70	1	25.40	1	25.40	1	25.40	24.38	21.84	29.46	14.22	39.62	43.43	29.46	-910
ALS 12-12UP	3/4	19.05	1-1/16-12	15.74	1-1/16	26.98	1-1/8	28.57	1-1/4	31.75	24.38	21.84	31.24	16.76	41.40	48.76	36.57	-912
ALS 14-14UP	7/8	22.22	1-3/16-12	18.28	1-1/4	31.75	1-1/4	31.75	1-3/8	34.92	25.90	21.84	33.02	16.76	43.18	50.54	40.38	-914
ALS 16-16UP	1	25.40	1-5/16-12	22.35	1-3/8	34.92	1-1/2	38.10	1-1/2	38.10	31.24	26.41	38.35	16.76	50.54	53.59	43.94	-916
ALS 20-20UP	1-1/4	31.75	1-5/8-12	27.68	1-11/16	42.76	1-7/8	47.63	1-7/8	47.63	41.14	38.86	45.72	16.76	67.81	58.16	54.86	-920
ALS 24-24UP	1-1/2	38.10	1-7/8-12	34.03	2	50.80	2-1/4	57.15	2-1/8	53.98	50.03	45.21	50.80	16.76	77.97	60.45	62.23	-924
ALS 32-32UP	2	50.80	2-1/2-12	45.97	2-3/4	69.85	3	76.20	2-3/4	69.85	67.56	62.73	69.85	16.76	107.18	71.62	80.26	-932

Positionable SAE  
Male Run Tee  
**ATRS-UP**

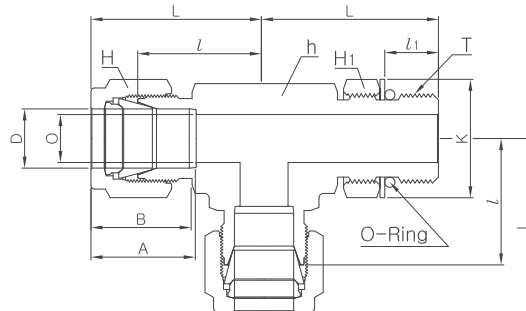
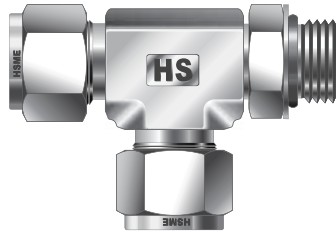

Connects fractional tube to SAE straight thread boss

Part No.	Tube O.D. D		Straight Thread T(U)	O Min.	Width across flat						A	B	/	/1	L	L1	K	O-Ring Uniform Size Number
	In	mm			h		H		H <sub>1</sub>									
					in	mm	in	mm	in	mm								
ATRS4-4UP	1/4	6.35	7/16-20	4.82	1/2	12.70	9/16	14.28	9/16	14.28	15.24	17.78	21.08	9.90	28.44	28.44	16.51	-904
ATRS6-6UP	3/8	9.52	9/16-18	7.11	5/8	15.87	11/16	17.46	11/16	17.46	16.76	19.30	24.63	11.17	32.00	32.25	20.06	-906
ATRS8-8UP	1/2	12.70	3/4-16	10.41	13/16	20.64	7/8	22.22	7/8	22.22	22.86	21.84	27.43	12.70	37.59	37.84	25.65	-908
ATRS12-12UP	3/4	19.05	1-1/16-12	15.74	1-1/8	26.98	1-1/8	28.58	1-1/4	31.75	24.38	21.84	31.24	16.76	41.40	48.76	36.57	-912
ATRS16-16UP	1	25.40	1-5/16-12	22.35	1-3/8	34.92	1-1/2	38.10	1-1/2	38.10	31.24	26.41	38.35	16.76	50.54	50.54	43.94	-916
ATRS20-20UP	1-1/4	31.75	1-5/8-12	27.68	1-11/16	42.86	1-7/8	47.63	1-7/8	47.63	41.14	38.86	45.72	16.76	67.81	58.16	54.86	-920
ATRS24-24UP	1-1/2	38.10	1-7/8-12	34.03	2	50.80	2-1/4	57.15	2-1/8	53.98	50.03	45.21	50.80	16.76	77.97	60.45	62.23	-924
ATRS32-32UP	2	50.80	2-1/2-12	45.97	2-3/4	69.85	3	76.20	2-3/4	69.85	67.56	62.73	69.85	16.76	107.18	71.62	80.26	-932

Positionable SAE  
Male Branch Tee  
**ATBS-UP**

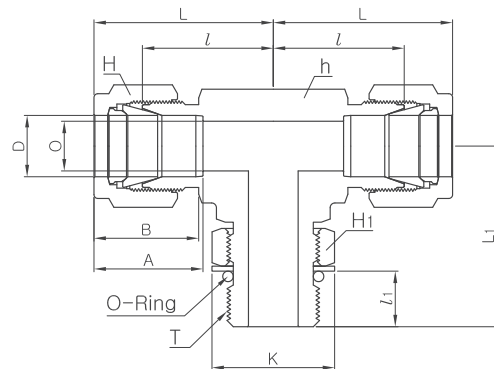
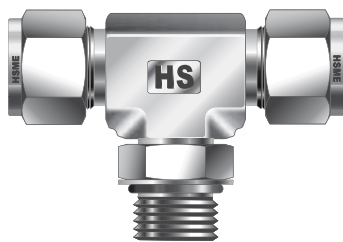

Connects fractional tube to SAE straight thread boss

Part No.	Tube O.D. D		Straight Thread T(U)	O Min.	Width across flat						A	B	/	/1	L	L1	K	O-Ring Uniform Size Number
	In	mm			h		H		H <sub>1</sub>									
					in	mm	in	mm	in	mm								
ATBS4-4UP	1/4	6.35	7/16-20	4.82	1/2	12.70	9/16	14.28	9/16	14.28	15.24	17.78	21.08	9.90	28.44	28.44	16.51	-904
ATBS6-6UP	3/8	9.52	9/16-18	7.11	5/8	15.87	11/16	17.46	11/16	17.46	16.76	19.30	24.63	11.17	32.00	32.25	20.06	-906
ATBS8-8UP	1/2	12.70	3/4-16	10.41	13/16	20.64	7/8	22.22	7/8	22.22	22.86	21.84	27.43	12.70	37.59	37.84	25.65	-908
ATBS12-12UP	3/4	19.05	1-1/16-12	15.74	1-1/16	26.98	1-1/8	28.58	1-1/4	31.75	24.38	21.84	31.24	16.76	41.40	48.76	36.57	-912
ATBS16-16UP	1	25.40	1-5/16-12	22.35	1-3/8	34.92	1-1/2	38.10	1-1/2	38.10	31.24	26.41	38.35	16.76	50.54	53.59	43.94	-916
ATBS20-20UP	1-1/4	31.75	1-5/8-12	27.68	1-11/16	42.86	1-7/8	47.63	1-7/8	47.63	41.14	38.86	45.72	16.76	67.81	58.16	54.86	-920
ATBS24-24UP	1-1/2	38.10	1-7/8-12	34.03	2	50.80	2-1/4	57.15	2-1/8	53.98	50.03	45.21	50.80	16.76	77.97	60.45	62.23	-924
ATBS32-32UP	2	50.80	2-1/2-12	45.97	2-3/4	69.85	3	76.20	2-3/4	69.85	67.56	62.73	69.85	16.76	107.18	71.62	80.26	-932

• Male NPT Run Tee

## ATRM-N

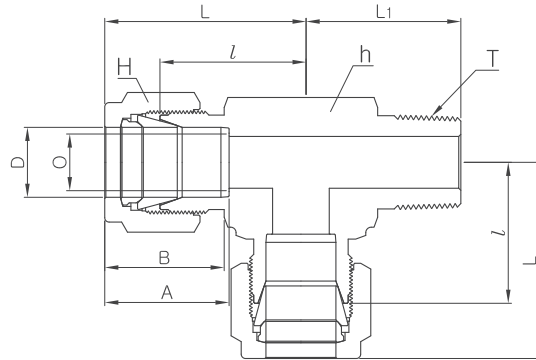
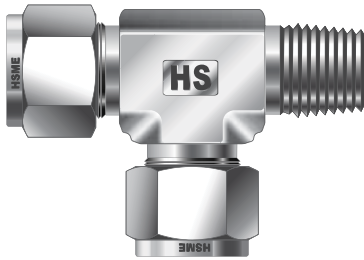

Connects fractional tube to female NPT thread

Part No.	Tube O.D. D		T NPT	O Min.	Width across flat				A	B	/	L	L1
	in	mm			h		H						
					in	mm	in	mm					
ATRM1-1N	1/16	1.59	1/16	1.27	7/16	11.11	5/16	7.93	8.63	10.92	15.24	19.05	17.78
ATRM1-2N	1/16	1.59	1/8	1.27	7/16	11.11	5/16	7.93	8.63	10.92	15.24	19.05	17.78
ATRM 2-2N	1/8	3.17	1/8	2.28	1/2	12.70	7/16	11.11	12.70	15.24	18.30	24.91	18.90
ATRM2-4N	1/8	3.17	1/4	2.28	1/2	12.70	7/16	11.11	12.70	15.24	18.30	24.91	23.26
ATRM3-2N	3/16	4.76	1/8	3.04	1/2	12.70	1/2	12.70	13.71	16.00	18.79	24.38	18.79
ATRM3-4N	3/16	4.76	1/4	3.04	1/2	12.70	1/2	12.70	13.71	16.00	18.79	25.40	23.36
ATRM4-1N	1/4	6.35	1/16	3.04	1/2	12.70	9/16	14.28	15.24	17.78	19.55	26.90	18.79
ATRM4-2N	1/4	6.35	1/8	4.82	1/2	12.70	9/16	14.28	15.24	17.78	19.55	26.92	18.79
ATRM4-4N	1/4	6.35	1/4	4.82	1/2	12.70	9/16	14.28	15.24	17.78	19.55	27.08	23.87
ATRM4-6N	1/4	6.35	3/8	4.82	11/16	17.46	9/16	14.28	15.24	17.78	22.35	29.71	28.40
ATRM4-8N	1/4	6.35	1/2	4.82	13/16	20.64	9/16	14.28	15.24	17.78	24.60	31.97	35.10
ATRM5-2N	5/16	7.93	1/8	4.82	9/16	14.28	5/8	15.87	16.25	18.54	22.35	29.71	19.81
ATRM5-4N	5/16	7.94	1/4	6.35	9/16	14.28	5/8	15.87	16.25	18.54	22.35	29.77	24.50
ATRM5-6N	5/16	7.94	3/8	6.35	11/16	17.46	5/8	15.87	16.25	18.54	23.11	30.48	28.40
ATRM6-4N	3/8	9.52	1/4	7.11	5/8	15.87	1/16	17.46	16.76	19.30	23.11	30.48	25.40
ATRM6-6N	3/8	9.52	3/8	7.11	11/16	17.46	11/16	17.46	16.76	19.30	23.87	31.24	28.44
ATRM6-8N	3/8	9.52	1/2	7.11	13/16	20.64	11/16	17.46	16.76	19.30	25.90	33.27	33.02
ATRM6-12N	3/8	9.52	3/4	7.11	1-1/16	26.98	11/16	17.46	16.76	19.30	29.71	37.08	36.83
ATRM8-4N	1/2	12.70	1/4	7.11	13/16	20.64	7/8	22.22	22.86	21.84	25.90	36.06	28.30
ATRM8-6N	1/2	12.70	3/8	9.65	13/16	20.64	7/8	22.22	22.86	21.84	25.90	36.06	28.30
ATRM8-8N	1/2	12.70	1/2	10.41	13/16	20.64	7/8	22.22	22.86	21.84	25.90	36.06	33.02
ATRM8-12N	1/2	12.70	3/4	10.41	1-1/16	26.98	7/8	22.22	22.86	21.84	29.71	39.84	36.83
ATRM10-6N	5/8	15.87	3/8	9.65	15/16	23.81	1	25.40	24.38	21.84	27.90	38.10	29.40
ATRM10-8N	5/8	15.87	1/2	11.93	15/16	23.81	1	25.40	24.38	21.84	27.90	38.10	34.00
ATRM10-12N	5/8	15.87	3/4	12.70	1-1/16	26.98	1	25.40	24.38	21.84	29.71	39.87	36.83
ATRM12-8N	3/4	19.05	1/2	11.93	1-1/16	26.98	1-1/8	28.58	24.38	21.84	29.71	39.87	37.00
ATRM12-12N	3/4	19.05	3/4	15.74	1-1/16	26.98	1-1/8	28.58	24.38	21.84	29.71	39.81	36.83
ATRM14-12N	7/8	22.23	3/4	15.74	1-3/8	34.92	1-1/4	31.75	25.90	21.84	34.54	44.70	41.65
ATRM16-12N	1	25.40	3/4	15.74	1-3/8	34.92	1-1/2	38.10	31.24	26.41	36.83	49.02	42.20
ATRM16-16N	1	25.40	1	22.35	1-3/8	34.92	1-1/2	38.10	31.24	26.41	36.83	49.02	46.70
ATRM20-20N	1-1/4	31.75	1-1/4	27.68	1-11/16	42.86	1-7/8	47.63	41.14	38.86	44.50	66.54	47.75
ATRM24-24N	1-1/2	38.10	1-1/2	34.03	2	50.80	2-1/4	57.15	50.03	45.21	50.80	77.97	60.45
ATRM32-32N	2	50.80	2	45.97	2-3/4	69.85	3	76.20	67.56	62.73	69.80	107.18	70.61

Male BSPT Run Tee

**ATRM-R**

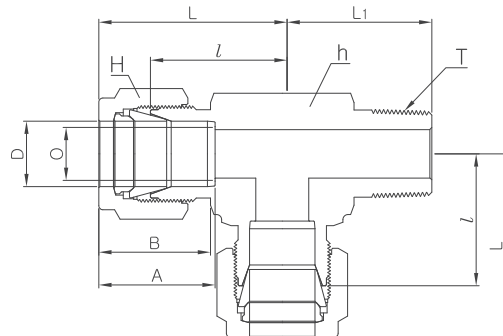
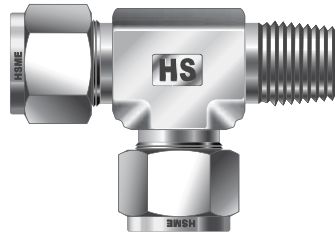

Connects fractional tube to female ISO tapered thread

Part No.	Tube O.D. D		T NPT	O Min.	Width across flat				A	B	/	L	L1
	in	mm			h		H						
					in	mm	in	mm					
ATRM6-4R	3/8	9.52	1/4	7.11	5/8	15.87	1/16	17.46	16.76	19.30	23.11	30.48	25.40
ATRM8-6R	1/2	12.70	3/8	9.65	13/16	20.64	7/8	22.22	22.86	21.84	25.90	36.06	28.30
ATRM 8-8R	1/2	12.70	1/2	10.41	13/16	20.64	7/8	22.22	22.86	21.84	25.90	36.06	33.02
ATRM10-8R	5/8	15.87	1/2	11.93	15/16	23.81	1	25.40	24.38	21.84	27.90	38.10	34.00

Connects metric tube to female ISO tapered thread

Part No.	Tube O.D. D	T R(PT)	O Min.	Width across flat		A	B	/	L	L1
				h	H					
ATRM3M-2R	3	1/8	2.4	12.7	12	12.9	15.3	17.0	23.6	17.8
ATRM3M-4R	3	1/4	2.4	12.7	12	12.9	15.3	18.0	24.6	23.4
ATRM4M-2R	4	1/8	2.4	12.7	12	13.7	16.1	18.8	25.4	18.8
ATRM4M-4R	4	1/4	2.4	12.7	12	13.7	16.1	18.8	25.4	23.4
ATRM6M-2R	6	1/8	4.8	12.7	14	15.3	17.7	19.6	27.0	18.8
ATRM6M-4R	6	1/4	4.8	14.2	14	15.3	17.7	19.6	27.0	23.4
ATRM6M-6R	6	3/8	4.8	17.5	14	15.3	17.7	22.4	29.8	26.2
ATRM6M-8R	6	1/2	4.8	20.6	14	15.3	17.7	24.4	31.8	33.0
ATRM8M-2R	8	1/8	4.8	14.3	16	16.2	18.6	21.3	28.8	19.8
ATRM8M-4R	8	1/4	6.4	14.3	16	16.2	18.6	21.3	28.8	24.4
ATRM8M-6R	8	3/8	6.4	17.5	16	16.2	18.6	23.1	30.6	26.2
ATRM8M-8R	8	1/2	6.4	20.6	16	16.2	18.6	25.1	32.6	33.0
ATRM10M-2R	10	1/8	4.8	17.5	19	17.2	19.5	23.9	31.5	23.6
ATRM10M-4R	10	1/4	7.1	17.5	19	17.2	19.5	23.9	31.5	26.2
ATRM10M-6R	10	3/8	7.9	17.5	19	17.2	19.5	23.9	31.5	26.2
ATRM10M-8R	10	1/2	7.9	20.6	19	17.2	19.5	25.9	33.5	33.0
ATRM12M-2R	12	1/8	4.8	20.6	22	22.8	22.0	25.9	36.0	23.6
ATRM12M-4R	12	1/4	7.1	20.6	22	22.8	22.0	25.9	36.0	28.2
ATRM12M-6R	12	3/8	9.5	20.6	22	22.8	22.0	25.9	36.0	28.2
ATRM12M-8R	12	1/2	9.5	20.6	22	22.8	22.0	25.9	36.0	33.0
ATRM12M-12R	12	3/4	9.5	27.0	22	22.8	22.0	29.7	39.8	36.8
ATRM16M-6R	16	3/8	9.5	25.4	25	24.4	22.0	27.9	38.0	30.2
ATRM16M-8R	16	1/2	11.9	25.4	25	24.4	22.0	27.9	38.0	35.1
ATRM16M-12R	16	3/4	12.7	27.0	25	24.4	22.0	29.7	39.8	36.8
ATRM18M-8R	18	1/2	11.9	27.0	30	24.4	22.0	29.7	39.8	36.8
ATRM18M-12R	18	3/4	15.1	27.0	30	24.4	22.0	29.7	39.8	36.8
ATRM20M-8R	20	1/2	11.9	34.92	32	26.0	22.0	34.5	44.6	41.7
ATRM20M-12R	20	3/4	15.9	34.92	32	26.0	22.0	34.5	44.6	41.7
ATRM22M-12R	22	3/4	15.9	34.92	32	26.0	22.0	34.5	44.6	41.7
ATRM22M-16R	22	1	18.3	34.92	32	26.0	22.0	34.5	44.6	46.5
ATRM25M-12R	25	3/4	15.9	34.92	38	31.3	26.5	36.8	49.1	41.7
ATRM25M-16R	25	1	21.8	34.92	38	31.3	26.5	36.8	49.1	46.5

- Male NPT Branch Tee

## ATBM-N

- Male BSPT Branch Tee

## ATBM-R

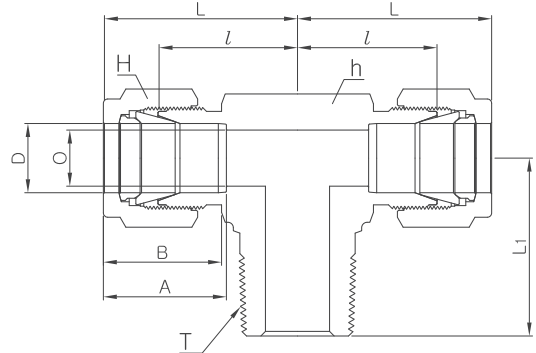
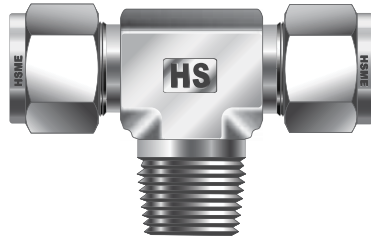

Connects fractional tube to female NPT thread

Part No.	Tube O.D. D		T NPT	O Min.	Width across flat				A	B	/	L	L1
	in	mm			h		H						
					in	mm	in	mm					
ATBM1-1N	1/16	1.59	1/16	1.27	7/16	11.11	5/16	7.93	8.63	10.92	15.24	19.05	17.78
ATBM1-2N	1/16	1.59	1/8	1.27	7/16	11.11	5/16	7.93	8.63	10.92	15.24	19.05	17.78
ATBM2-2N	1/8	3.17	1/8	2.28	1/2	12.70	7/16	11.11	12.70	15.24	18.30	24.91	18.90
ATBM2-4N	1/8	3.17	1/4	2.28	1/2	12.70	7/16	11.11	12.70	15.24	18.30	24.91	23.26
ATBM3-2N	3/16	4.76	1/8	3.04	1/2	12.70	1/2	12.70	13.71	16.00	18.79	24.38	18.79
ATBM3-4N	3/16	4.76	1/4	3.04	1/2	12.70	1/2	12.70	13.71	16.00	18.79	25.40	23.36
ATBM4-1N	1/4	6.35	1/16	3.04	1/2	12.70	9/16	14.28	15.24	17.78	19.55	26.90	18.79
ATBM4-2N	1/4	6.35	1/8	4.82	1/2	12.70	9/16	14.28	15.24	17.78	19.55	26.92	18.79
ATBM4-4N	1/4	6.35	1/4	4.82	1/2	12.70	9/16	14.28	15.24	17.78	19.55	27.08	23.87
ATBM4-6N	1/4	6.35	3/8	4.82	11/16	17.46	9/16	14.28	15.24	17.78	22.35	29.71	28.40
ATBM4-8N	1/4	6.35	1/2	4.82	13/16	20.64	9/16	14.28	15.24	17.78	24.60	31.97	35.10
ATBM5-2N	5/16	7.93	1/8	4.82	9/16	14.28	5/8	15.87	16.25	18.54	22.35	29.71	19.81
ATBM5-4N	5/16	7.94	1/4	6.35	9/16	14.28	5/8	15.87	16.25	18.54	22.35	29.77	24.50
ATBM5-6N	5/16	7.94	3/8	6.35	11/16	17.46	5/8	15.87	16.25	18.54	23.11	30.48	28.40
ATBM6-4N	3/8	9.52	1/4	7.11	5/8	15.87	1/16	17.46	16.76	19.30	23.11	30.48	25.40
ATBM6-6N	3/8	9.52	3/8	7.11	11/16	17.46	11/16	17.46	16.76	19.30	23.87	31.24	28.44
ATBM6-8N	3/8	9.52	1/2	7.11	13/16	20.64	11/16	17.46	16.76	19.30	25.90	33.27	33.02
ATBM6-12N	3/8	9.52	3/4	7.11	1-1/16	26.98	11/16	17.46	16.76	19.30	29.71	37.08	36.83
ATBM8-4N	1/2	12.70	1/4	7.11	13/16	20.64	7/8	22.22	22.86	21.84	25.90	36.06	28.30
ATBM8-6N	1/2	12.70	3/8	9.65	13/16	20.64	7/8	22.22	22.86	21.84	25.90	36.06	28.30
ATBM8-8N	1/2	12.70	1/2	10.41	13/16	20.64	7/8	22.22	22.86	21.84	25.90	36.06	33.02
ATBM8-12N	1/2	12.70	3/4	10.41	1-1/16	26.98	7/8	22.22	22.86	21.84	29.71	39.84	36.83
ATBM10-6N	5/8	15.87	3/8	9.65	15/16	23.81	1	25.40	24.38	21.84	27.90	38.10	29.40
ATBM10-8N	5/8	15.87	1/2	11.93	15/16	23.81	1	25.40	24.38	21.84	27.90	38.10	34.00
ATBM10-12N	5/8	15.87	3/4	12.70	1-1/16	26.98	1	25.40	24.38	21.84	29.71	39.87	36.83
ATBM12-8N	3/4	19.05	1/2	11.93	1-1/16	26.98	1-1/8	28.58	24.38	21.84	29.71	39.87	37.00
ATBM12-12N	3/4	19.05	3/4	15.74	1-1/16	26.98	1-1/8	28.58	24.38	21.84	29.71	39.81	36.83
ATBM14-12N	7/8	22.23	3/4	15.74	1-3/8	34.92	1-1/4	31.75	25.90	21.84	34.54	44.70	41.65
ATBM16-12N	1	25.40	3/4	15.74	1-3/8	34.92	1-1/2	38.10	31.24	26.41	36.83	49.02	42.20
ATBM16-16N	1	25.40	1	22.35	1-3/8	34.92	1-1/2	38.10	31.24	26.41	36.83	49.02	46.70
ATBM20-20N	1-1/4	31.75	1-1/4	27.68	1-11/16	42.86	1-7/8	47.63	41.14	38.86	44.50	66.54	47.75
ATBM24-24N	1-1/2	38.10	1-1/2	34.03	2	50.80	2-1/4	57.15	50.03	45.21	50.80	77.97	60.45
ATBM32-32N	2	50.80	2	45.97	2-3/4	69.85	3	76.20	67.56	62.73	69.80	107.18	70.61

Connects fractional tube to female ISO tapered thread

Part No.	Tube O.D. D		T PT	O Min.	Width across flat				A	B	/	L	L1
	in	mm			h		H						
					in	mm	in	mm					
ATBM6-4R	3/8	9.52	1/4	7.11	5/8	15.87	1/16	17.46	16.76	19.30	23.11	30.48	25.40
ATBM8-6R	1/2	12.70	3/8	9.65	13/16	20.64	7/8	22.22	22.86	21.84	25.90	36.06	28.30
ATBM8-8R	1/2	12.70	1/2	10.41	13/16	20.64	7/8	22.22	22.86	21.84	25.90	36.06	33.02
ATBM10-8R	5/8	15.87	1/2	11.93	15/16	23.81	1	25.40	24.38	21.84	27.90	38.10	34.00



Male NPT Branch Tee  
**ATBM-N**

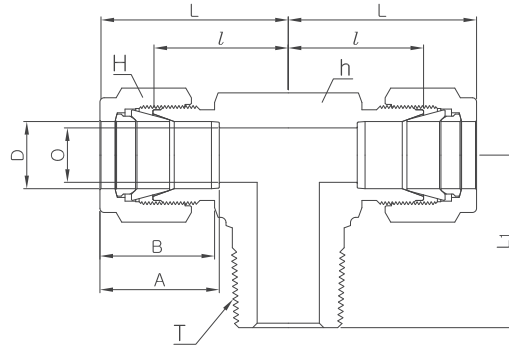

Connects metric tube to female NPT thread

Part No.	Tube O.D. D	T NPT	O Min.	Width across flat		A	B	l	L	L1
				h	H					
ATBM3M-2N	3	1/8	2.4	12.7	12	12.9	15.3	17.0	23.6	17.8
ATBM3M-4N	3	1/4	2.4	12.7	12	12.9	15.3	18.0	24.6	23.4
ATBM4M-2N	4	1/8	2.4	12.7	12	13.7	16.1	18.8	25.4	18.8
ATBM4M-4N	4	1/4	2.4	12.7	12	13.7	16.1	18.8	25.4	23.4
ATBM6M-2N	6	1/8	4.8	12.7	14	15.3	17.7	19.6	27.0	18.8
ATBM6M-4N	6	1/4	4.8	14.2	14	15.3	17.7	19.6	27.0	23.4
ATBM6M-6N	6	3/8	4.8	17.5	14	15.3	17.7	22.4	29.8	26.2
ATBM6M-8N	6	1/2	4.8	20.6	14	15.3	17.7	24.4	31.8	33.0
ATBM8M-2N	8	1/8	4.8	14.3	16	16.2	18.6	21.3	28.8	19.8
ATBM8M-4N	8	1/4	6.4	14.3	16	16.2	18.6	21.3	28.8	24.4
ATBM8M-6N	8	3/8	6.4	17.5	16	16.2	18.6	23.1	30.6	26.2
ATBM8M-8N	8	1/2	6.4	20.6	16	16.2	18.6	25.1	32.6	33.0
ATBM10M-2N	10	1/8	4.8	17.5	19	17.2	19.5	23.9	31.5	23.6
ATBM10M-4N	10	1/4	7.1	17.5	19	17.2	19.5	23.9	31.5	26.2
ATBM10M-6N	10	3/8	7.9	17.5	19	17.2	19.5	23.9	31.5	26.2
ATBM10M-8N	10	1/2	7.9	20.6	19	17.2	19.5	25.9	33.5	33.0
ATBM12M-2N	12	1/8	4.8	20.6	22	22.8	22.0	25.9	36.0	23.6
ATBM12M-4N	12	1/4	7.1	20.6	22	22.8	22.0	25.9	36.0	28.2
ATBM12M-6N	12	3/8	9.5	20.6	22	22.8	22.0	25.9	36.0	28.2
ATBM12M-8N	12	1/2	9.5	20.6	22	22.8	22.0	25.9	36.0	33.0
ATBM12M-12N	12	3/4	9.5	27.0	22	22.8	22.0	29.7	39.8	36.8
ATBM16M-6N	16	3/8	9.5	25.4	25	24.4	22.0	27.9	38.0	30.2
ATBM16M-8N	16	1/2	11.9	25.4	25	24.4	22.0	27.9	38.0	35.1
ATBM16M-12N	16	3/4	12.7	27.0	25	24.4	22.0	29.7	39.8	36.8
ATBM18M-8N	18	1/2	11.9	27.0	30	24.4	22.0	29.7	39.8	36.8
ATBM18M-12N	18	3/4	15.1	27.0	30	24.4	22.0	29.7	39.8	36.8
ATBM20M-8N	20	1/2	11.9	34.92	32	26.0	22.0	34.5	44.6	41.7
ATBM20M-12N	20	3/4	15.9	34.92	32	26.0	22.0	34.5	44.6	41.7
ATBM22M-12N	22	3/4	15.9	34.92	32	26.0	22.0	34.5	44.6	41.7
ATBM22M-16N	22	1	18.3	34.92	32	26.0	22.0	34.5	44.6	46.5
ATBM25M-12N	25	3/4	15.9	34.92	38	31.3	26.5	36.8	49.1	41.7
ATBM25M-16N	25	1	21.8	34.92	38	31.3	26.5	36.8	49.1	46.5

• Male BSPT Branch Tee  
**ATBM-R**

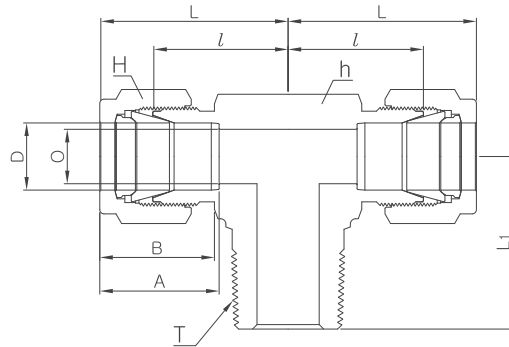

Connects metric tube to female ISO tapered thread

Part No.	Tube O.D. D	T R(PT)	O Min.	Width across flat		A	B	l	L	L1
				h	H					
ATBM3M-2R	3	1/8	2.4	12.7	12	12.9	15.3	17.0	23.6	17.8
ATBM3M-4R	3	1/4	2.4	12.7	12	12.9	15.3	18.0	24.6	23.4
ATBM4M-2R	4	1/8	2.4	12.7	12	13.7	16.1	18.8	25.4	18.8
ATBM4M-4R	4	1/4	2.4	12.7	12	13.7	16.1	18.8	25.4	23.4
ATBM6M-2R	6	1/8	4.8	12.7	14	15.3	17.7	19.6	27.0	18.8
ATBM6M-4R	6	1/4	4.8	14.2	14	15.3	17.7	19.6	27.0	23.4
ATBM6M-6R	6	3/8	4.8	17.5	14	15.3	17.7	22.4	29.8	26.2
ATBM6M-8R	6	1/2	4.8	20.6	14	15.3	17.7	24.4	31.8	33.0
ATBM8M-2R	8	1/8	4.8	14.3	16	16.2	18.6	21.3	28.8	19.8
ATBM8M-4R	8	1/4	6.4	14.3	16	16.2	18.6	21.3	28.8	24.4
ATBM8M-6R	8	3/8	6.4	17.5	16	16.2	18.6	23.1	30.6	26.2
ATBM8M-8R	8	1/2	6.4	20.6	16	16.2	18.6	25.1	32.6	33.0
ATBM10M-2R	10	1/8	4.8	17.5	19	17.2	19.5	23.9	31.5	23.6
ATBM10M-4R	10	1/4	7.1	17.5	19	17.2	19.5	23.9	31.5	26.2
ATBM10M-6R	10	3/8	7.9	17.5	19	17.2	19.5	23.9	31.5	26.2
ATBM10M-8R	10	1/2	7.9	20.6	19	17.2	19.5	25.9	33.5	33.0
ATBM12M-2R	12	1/8	4.8	20.6	22	22.8	22.0	25.9	36.0	23.6
ATBM12M-4R	12	1/4	7.1	20.6	22	22.8	22.0	25.9	36.0	28.2
ATBM12M-6	12	3/8	9.5	20.6	22	22.8	22.0	25.9	36.0	28.2
ATBM12M-8R	12	1/2	9.5	20.6	22	22.8	22.0	25.9	36.0	33.0
ATBM12M-12R	12	3/4	9.5	27.0	22	22.8	22.0	29.7	39.8	36.8
ATBM16M-6R	16	3/8	9.5	25.4	25	24.4	22.0	27.9	38.0	30.2
ATBM16M-8R	16	1/2	11.9	25.4	25	24.4	22.0	27.9	38.0	35.1
ATBM16M-12R	16	3/4	12.7	27.0	25	24.4	22.0	29.7	39.8	36.8
ATBM18M-8R	18	1/2	11.9	27.0	30	24.4	22.0	29.7	39.8	36.8
ATBM18M-12R	18	3/4	15.1	27.0	30	24.4	22.0	29.7	39.8	36.8
ATBM20M-8R	20	1/2	11.9	34.92	32	26.0	22.0	34.5	44.6	41.7
ATBM20M-12R	20	3/4	15.9	34.92	32	26.0	22.0	34.5	44.6	41.7
ATBM22M-12R	22	3/4	15.9	34.92	32	26.0	22.0	34.5	44.6	41.7
ATBM22M-16R	22	1	18.3	34.92	32	26.0	22.0	34.5	44.6	46.5
ATBM25M-12R	25	3/4	15.9	34.92	38	31.3	26.5	36.8	49.1	41.7
ATBM25M-16R	25	1	21.8	34.92	38	31.3	26.5	36.8	49.1	46.5

• Female NPT Connector  
**ACF-N**

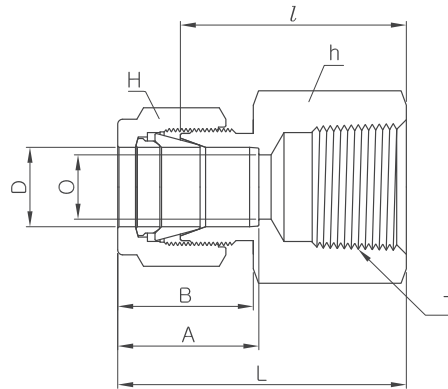
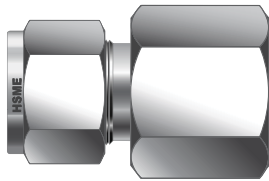

Connects fractional tube to male NPT thread

Part No.	Tube O.D.		T NPT	O Min.	Width across flat				A	B	/	L
	D				h		H					
	in	mm			in	mm	in	mm				
ACF1-1N	1/16	1.59	1/16	1.27	7/16	11.11	5/16	7.93	8.63	10.92	19.81	23.62
ACF1-2N	1/16	1.59	1/8	1.27	9/16	14.28	5/16	7.93	8.63	10.92	20.57	24.38
ACF2-2N	1/8	3.17	1.8	2.28	9/16	14.28	7/16	11.11	12.70	15.24	22.09	28.70
ACF2-4N	1/8	3.17	1/4	2.28	3/4	19.05	7/16	11.11	12.70	15.24	26.92	33.52
ACF3-2N	3/16	4.76	1/8	3.04	9/16	14.28	1/2	12.70	13.71	16.00	23.11	29.71
ACF4-2N	1/4	6.35	1/8	4.82	9/16	14.28	9/16	14.28	15.24	17.78	23.87	31.24
ACF4-4N	1/4	6.35	1/4	4.82	3/4	19.05	9/16	14.28	15.24	17.78	28.44	35.81
ACF4-6N	1/4	6.35	3/8	4.82	7/8	22.22	9/16	14.28	15.24	17.78	30.22	37.59
ACF4-8N	1/4	6.35	1/2	4.82	1-1/16	26.98	9/16	14.28	15.24	17.78	35.05	42.41
ACF5-2N	5/16	7.93	1/8	6.35	9/16	14.28	5/8	15.87	16.25	18.54	24.63	32.00
ACF5-4N	5/16	7.93	1/4	6.35	3/4	19.05	5/8	15.87	16.25	18.54	29.46	36.83
ACF6-2N	3/8	9.52	1/8	7.11	5/8	15.87	11/16	17.46	17.46	16.76	19.30	25.40
ACF6-4N	3/8	9.52	1/4	7.11	3/4	19.05	11/16	17.46	16.76	19.30	30.22	37.59
ACF6-6N	3/8	9.52	3/8	7.11	7/8	22.22	11/16	17.46	16.76	19.30	31.75	39.11
ACF6-8N	3/8	9.52	1/2	7.11	1-1/16	26.98	11/16	17.46	16.76	19.30	36.57	43.94
ACF6-12N	3/8	9.52	3/4	7.11	1-5/16	33.33	11/16	17.46	16.76	19.30	40.38	47.45
ACF8-4N	1/2	12.70	1/4	10.41	1-3/16	20.64	7/8	22.22	22.86	21.84	30.22	40.38
ACF8-6N	1/2	12.70	3/8	10.41	7/8	22.22	7/8	22.22	22.86	21.84	31.75	41.91
ACF8-8N	1/2	12.70	1/2	10.41	1-1/16	26.98	7/8	22.22	22.86	21.84	36.57	46.73
ACF8-12N	1/2	12.70	3/4	10.41	1-5/16	33.33	7/8	22.22	22.86	21.84	38.10	48.26
ACF10-6N	5/8	15.87	3/8	12.70	15/16	23.81	1	25.40	24.38	21.84	31.75	41.91
ACF10-8N	5/8	15.87	1/2	12.70	1-1/16	26.98	1	25.40	24.38	21.84	36.57	46.73
ACF10-12N	5/8	15.87	3/4	12.70	1-5/16	33.33	1	25.40	24.38	21.84	38.10	48.26
ACF12-8N	3/4	19.05	1/2	15.74	1-1/16	26.98	1-1/8	28.58	24.38	21.84	36.57	46.73
ACF12-12N	3/4	19.05	3/4	15.74	1-5/16	33.33	1-1/8	28.58	24.38	21.84	38.10	48.26
ACF14-12N	7/8	22.22	3/4	18.28	1-5/16	33.33	1-1/4	31.75	25.90	21.84	39.62	49.78
ACF16-12N	1	25.40	3/4	22.35	1-3/8	34.92	1-1/2	38.10	31.24	26.41	41.14	53.34
ACF16-16N	1	25.40	1	22.35	1-5/8	41.27	1-1/2	38.10	31.24	26.41	50.03	62.23
ACF20-20N	1-1/4	31.75	1-1/4	27.68	2-1/8	53.98	1-7/8	47.63	41.14	38.86	52.57	74.67
ACF24-24N	1-1/2	38.10	1-1/2	34.03	2-3/8	60.33	2-1/4	57.15	50.03	45.21	56.13	83.81
ACF32-32N	2	50.80	2	45.97	2-1/8	73.03	3	76.20	67.56	62.73	64.26	101.60

• Female NPT Connector  
**ACF-N**

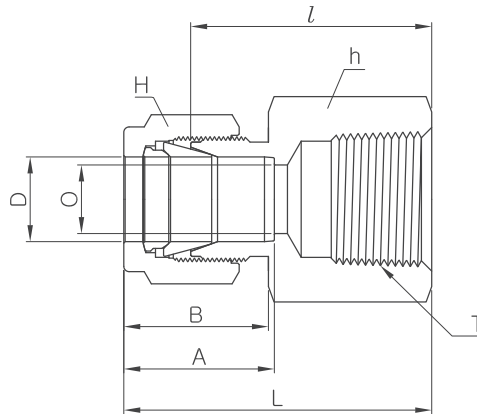
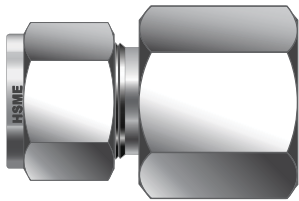

Connects metric tube to male NPT thread

Part No.	Tube O.D. D	T NPT	O Min.	Width across flat		A	B	l	L
				h	H				
ACF3M-2N	3	1/8	2.4	14	12	12.9	15.3	22.1	28.7
ACF3M-4N	3	1/4	2.4	19	12	12.9	15.3	26.9	33.5
ACF4M-2N	4	1/8	2.4	14	12	13.7	16.1	23.1	29.7
ACF6M-2N	6	1/8	4.8	14	14	15.3	17.7	23.9	31.3
ACF6M-4N	6	1/4	4.8	19	14	15.3	17.7	28.4	35.8
ACF6M-6N	6	3/8	4.8	22	14	15.3	17.7	29.5	36.9
ACF6M-8N	6	1/2	4.8	27	14	15.3	17.7	35.1	42.5
ACF8M-2N	8	1/8	6.4	15	16	16.2	18.6	24.6	32.1
ACF8M-4N	8	1/4	6.4	19	16	16.2	18.6	29.5	37.0
ACF8M-6N	8	3/8	6.4	22	16	16.2	18.6	30.2	37.7
ACF8M-8N	8	1/2	6.4	27	16	16.2	18.6	35.8	43.3
ACF10M-2N	10	1/8	7.9	18	19	17.2	19.5	25.4	33.0
ACF10M-4N	10	1/4	7.9	19	19	17.2	19.5	30.2	37.8
ACF10M-6N	10	3/8	7.9	22	19	17.2	19.5	31.0	38.6
ACF10M-8N	10	1/2	7.9	27	19	17.2	19.5	36.6	44.2
ACF12M-2N	12	1/8	8.3	22	22	22.8	22.0	28.4	38.5
ACF12M-4N	12	1/4	9.5	22	22	22.8	22.0	30.2	4.03
ACF12M-6N	12	3/8	9.5	22	22	22.8	22.0	31.0	41.1
ACF12M-8N	12	1/2	9.5	27	22	22.8	22.0	36.6	46.7
ACF12M-12N	12	3/4	9.5	35	22	22.8	22.0	38.9	49.0
ACF15M-8N	15	1/2	11.9	27	25	24.4	22.0	36.6	46.7
ACF16M-8N	16	1/2	12.7	27	25	24.4	22.0	36.8	46.9
ACF20M-8N	20	1/2	15.9	30	32	26.0	22.0	37.8	47.9
ACF20M-12N	20	3/4	15.9	35	32	26.0	22.0	39.6	49.7
ACF22M-12N	22	3/4	18.3	35	32	26.0	22.0	39.6	49.7
ACF22M-16N	22	1	18.3	41	32	26.0	22.0	47.8	57.9
ACF25M-12N	25	3/4	21.8	35	38	31.3	26.5	41.1	53.4
ACF25M-16N	25	1	21.8	41	38	31.3	26.5	50.0	62.3

Female BSPT Connector  
**ACF-R**

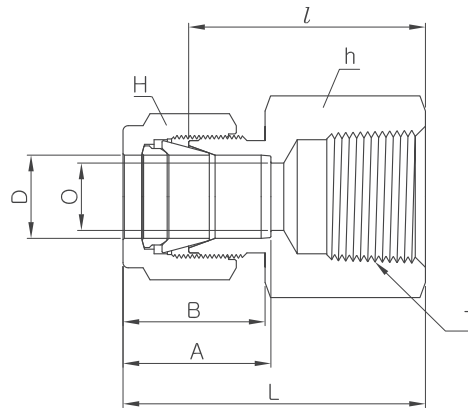
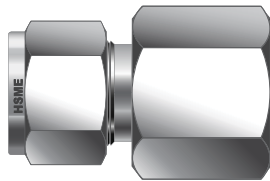

Connects fractional tube to male ISO tapered thread

Part No.	Tube O.D. D		T PT	O Min.	Width across flat				A	B	l	L
	in	mm			h		H					
					in	mm	in	mm				
ACF 2-2R	1/8	3.17	1/8	2.28	9/16	14.28	7/16	11.11	12.70	15.24	22.09	28.70
ACF4-2R	1/4	6.35	1/8	4.82	9/16	14.28	9/16	14.28	15.24	17.78	23.87	31.24
ACF4-4R	1/4	6.35	1/4	4.82	3/4	19.05	9/16	14.28	15.24	17.78	28.44	35.81
ACF4-6R	1/4	6.35	3/8	4.82	7/8	22.22	9/16	14.28	15.24	17.78	30.22	37.59
ACF4-8R	1/4	6.35	1/2	4.82	1-1/16	26.98	9/16	14.28	15.24	17.78	35.05	42.41
ACF6-4R	3/8	9.52	1/4	7.11	3/4	19.05	11/16	17.46	16.76	19.30	30.22	37.59
ACF6-6R	3/8	9.52	3/8	7.11	7/8	22.22	11/16	17.46	16.76	19.30	31.75	39.11
ACF6-8R	3/8	9.52	1/2	7.11	1-1/16	26.98	11/16	17.46	16.76	19.30	36.57	43.94
ACF8-2R	1/2	12.70	1/8	10.41	13/16	20.64	7/8	22.22	22.86	21.84	25.40	35.56
ACF8-4R	1/2	12.70	1/4	10.41	1-3/16	20.64	7/8	22.22	22.86	21.84	30.22	40.38
ACF8-6R	1/2	12.70	3/8	10.41	7/8	22.22	7/8	22.22	22.86	21.84	31.75	41.91
ACF8-8R	1/2	12.70	1/2	10.41	1-1/16	26.98	7/8	22.22	22.86	21.84	36.57	46.73
ACF8-12R	1/2	12.70	3/4	10.41	1-5/16	33.33	7/8	22.22	22.86	21.84	38.10	48.26
ACF10-6R	5/8	15.87	3/8	12.70	15/16	23.81	1	25.40	24.38	21.84	31.75	41.91
ACF10-8R	5/8	15.87	1/2	12.70	1-1/16	26.98	1	25.40	24.38	21.84	36.57	46.73
ACF10-12R	5/8	15.87	3/4	12.70	1-5/16	33.33	1	25.40	24.38	21.84	38.10	48.26
ACF12-8R	3/4	19.05	1/2	15.74	1-1/16	26.98	1-1/8	28.58	24.38	21.84	36.57	46.73
ACF12-12R	3/4	19.05	3/4	15.74	1-5/16	33.33	1-1/8	28.58	24.38	21.84	38.10	48.26
ACF16-12R	1	25.40	3/4	22.35	1-3/8	34.92	1-1/2	38.10	31.24	26.41	41.14	53.34
ACF16-16R	1	25.40	1	22.35	1-5/8	41.27	1-1/2	38.10	31.24	26.41	50.03	62.23
ACF20-16R	1-1/4	31.75	1	27.68	1-3/4	44.45	1-7/8	47.63	41.14	38.86	52.57	74.67
ACF20-20R	1-1/4	31.75	1-1/4	27.68	2-1/8	53.98	1-7/8	47.63	41.14	38.86	52.57	74.67
ACF24-24R	1-1/2	38.10	1-1/2	34.03	2-3/8	60.33	2-1/4	57.15	50.03	45.21	56.13	83.81

Female BSPT  
Connector  
**ACF-R**

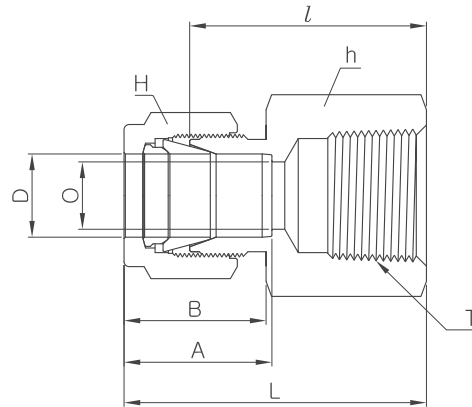
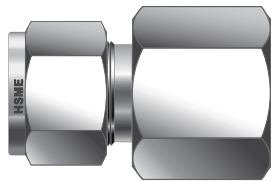

Connects metric tube to male ISO tapered thread

Part No.	Tube O.D. D	T R(PT)	O Min.	Width across flat		A	B	l	L
				h	H				
ACF3M-2R	3	1/8	2.4	14	12	12.9	15.3	22.1	28.7
ACF3M-4R	3	1/4	2.4	19	12	12.9	15.3	26.9	33.5
ACF4M-2R	4	1/8	2.4	14	12	13.7	16.1	23.1	29.7
ACF6M-2R	6	1/8	4.8	14	14	15.3	17.7	23.9	31.3
ACF6M-4R	6	1/4	4.8	19	14	15.3	17.7	28.4	35.8
ACF6M-6R	6	3/8	4.8	22	14	15.3	17.7	29.5	36.9
ACF6M-8R	6	1/2	4.8	27	14	15.3	17.7	35.1	42.5
ACF8M-2R	8	1/8	6.4	15	16	16.2	18.6	24.6	32.1
ACF8M-4R	8	1/4	6.4	19	16	16.2	18.6	29.5	37.0
ACF8M-6R	8	3/8	6.4	22	16	16.2	18.6	30.2	37.7
ACF8M-8R	8	1/2	6.4	27	16	16.2	18.6	35.8	43.3
ACF10M-2R	10	1/8	7.9	18	19	17.2	19.5	25.4	33.0
ACF10M-4R	10	1/4	7.9	19	19	17.2	19.5	30.2	37.8
ACF10M-6R	10	3/8	7.9	22	19	17.2	19.5	31.0	38.6
ACF10M-8R	10	1/2	7.9	27	19	17.2	19.5	36.6	44.2
ACF12M-2R	12	1/8	8.3	22	22	22.8	22.0	28.4	38.5
ACF12M-4R	12	1/4	9.5	22	22	22.8	22.0	30.2	40.3
ACF12M-6R	12	3/8	9.5	22	22	22.8	22.0	31.0	41.1
ACF12M-8R	12	1/2	9.5	27	22	22.8	22.0	36.6	46.7
ACF12M-12R	12	3/4	9.5	35	22	22.8	22.0	38.9	49.0
ACF15M-8R	15	1/2	11.9	27	25	24.4	22.0	36.6	46.7
ACF16M-8R	16	1/2	12.7	27	25	24.4	22.0	36.8	46.9
ACF20M-8R	20	1/2	15.9	30	32	26.0	22.0	37.8	47.9
ACF20M-12R	20	3/4	15.9	35	32	26.0	22.0	39.6	49.7
ACF22M-12R	22	3/4	18.3	35	32	26.0	22.0	39.6	49.7
ACF22M-16R	22	1	18.3	41	32	26.0	22.0	47.8	57.9
ACF25M-12R	25	3/4	21.8	35	38	31.3	26.5	41.1	53.4
ACF25M-16R	25	1	21.8	41	38	31.3	26.5	50.0	62.3

## Parallel Pipe Threads – Female

### ISO 228-1

Pipe threads where pressure-tight joints are not made on the threads

#### Thread Designator: GG

Thread end form to DIN 3852 Form Y

Sealing by copper gasket



A copper gasket is dropped into the flat bottom of female port. The face of gauge male thread exerts a load over the gasket for sealing.

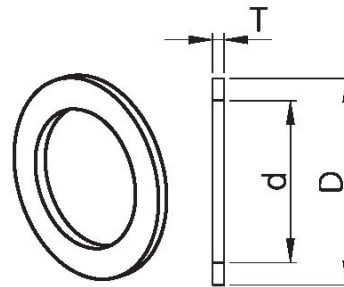

#### Copper Gasket Ordering Information and Dimensions

Thread in.	Dimensions, mm (in.)			Part Number
	D	d	T	
1/8	8.2 (0.322)	5.5 (0.218)	1.6 (0.062)	9PP-2GG-CU
1/4	11.1 (0.436)	7.9 (0.312)		9PP-4GG-CU
3/8	14.6 (0.574)	11.1 (0.437)		9PP-6GG-CU
1/2	18.3 (0.719)	14.3 (0.562)		9PP-8GG-CU
3/4	23.7 (0.935)	20.6 (0.812)		9PP-12GG-CU
1	29.9 (1.178)	25.4 (1)		2.4 (0.093)

Female  
Gauge Connector  
**ACF-GG**

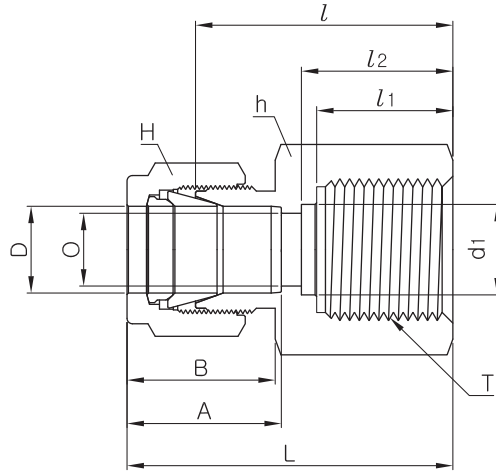
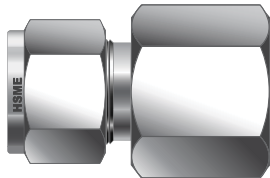

Connects fractional tube to Gauge (male ISO parallel thread)

Part No.	Tube O.D. D		T PT	O Min.	O1	Width across flat				A	B	l	l1	L
	in	mm				h		H						
						in	mm	in	mm					
ACF2-4GG	1/8	3.17	1/4	2.4	5.5	3/4	19.05	7/16	11.11	12.70	15.24	28.70	13.00	35.31
ACF4-2GG	1/4	6.35	1/8	4.82	-	9/16	14.28	9/16	14.28	15.24	17.78	26.30	12.00	33.55
ACF4-4GG	1/4	6.35	1/4	4.82	5.5	3/4	19.05	9/16	14.28	15.24	17.78	30.22	13.00	37.59
ACF4-6GG	1/4	6.35	3/8	4.82	6.5	15/16	23.81	9/16	14.28	15.24	17.78	30.22	14.22	37.59
ACF4-8GG	1/4	6.35	1/2	4.82	7.0	1-1/16	26.98	9/16	14.28	15.24	17.78	30.07	18.80	43.43
ACF5-4GG	5/16	7.93	1/4	5.58	5.5	3/4	19.05	5/8	15.87	16.25	18.54	30.98	13.00	38.35
ACF5-8GG	5/16	7.93	1/2	7.11	7.0	1-1/16	26.98	5/8	15.87	16.25	18.54	33.02	18.80	40.38
ACF6-4GG	3/8	9.52	1/4	5.58	5.5	3/4	19.05	11/16	17.46	16.76	19.30	31.75	12.95	39.12
ACF6-6GG	3/8	9.52	3/8	6.60	6.5	15/16	23.81	11/16	17.46	16.76	19.30	31.24	14.22	38.61
ACF6-8GG	3/8	9.52	1/2	7.11	7.0	1-1/16	26.98	11/16	17.46	16.76	19.30	34.54	18.80	41.91
ACF8-4GG	1/2	12.70	1/4	5.50	5.5	7/8	22.22	7/8	22.22	22.86	21.84	31.80	13.00	41.95
ACF8-6GG	1/2	12.70	3/8	6.60	6.5	15/16	23.81	7/8	22.22	22.86	21.84	34.29	14.24	44.45
ACF8-8GG	1/2	12.70	1/2	7.11	7.0	1-1/16	26.98	7/8	22.22	22.86	21.84	38.10	18.80	48.26

Connects metric tube to Gauge (male ISO parallel thread)

Part No.	Tube O.D. D	T R(PT)	O Min.	Width across flat		A	B	l	L1	L
				h	H					
ACF3M-4GG	3	1/4	2.4	19	12	12.9	15.3	28.7	13	35.3
ACF6M-4GG	6	1/4	4.8	19	14	15.3	17.7	30.2	13	37.6
ACF6M-6GG	6	3/8	4.8	24	14	15.3	17.7	30.2	14	37.6
ACF6M-8GG	6	1/2	4.8	27	14	15.3	17.7	36.3	19	43.0
ACF8M-4GG	8	1/4	5.5	19	16	16.2	18.6	31.0	13	38.5
ACF8M-6GG	8	3/8	6.5	24	16	16.2	18.6	28.7	14	36.2
ACF8M-8GG	8	1/2	7.0	27	16	16.2	18.6	33.0	19	40.5
ACF10M-4GG	10	1/4	5.5	19	19	17.2	19.5	31.8	13	39.4
ACF10M-6GG	10	3/8	6.5	24	19	17.2	19.5	31.2	14	38.8
ACF10M-8GG	10	1/2	7.0	27	19	17.2	19.5	33.8	19	41.4
ACF12M-4GG	12	1/4	5.5	22	22	22.8	22.0	31.8	13	41.9
ACF12M-6GG	12	3/8	6.5	24	22	22.8	22.0	34.3	14	44.4
ACF12M-8GG	12	1/2	7.0	27	22	22.8	22.0	38.1	19	48.2
ACF20M-8GG	20	1/2	7.0	30	32	26.0	22.0	44.2	19	54.3
ACF22M-8GG	22	1/2	7.0	30	32	26.0	22.0	44.2	19	54.3



Bulkhead Female  
NPT Connector  
**ACBF-N**

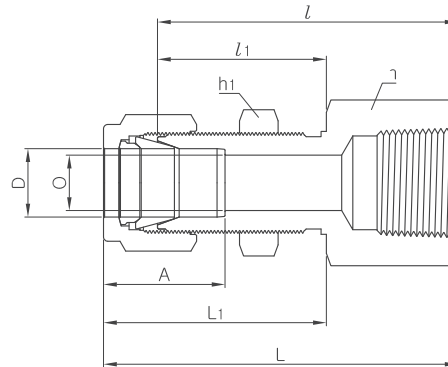
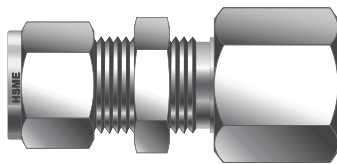

Connects fractional tube to male NPT thread

Part No.	Tube O.D. D		T NPT	O Min.	Width across flat						A	/	/1	L	L1	Panel Hole Drill size	Panel Max Thickness
	in	mm			h		h1		H								
					in	mm	in	mm	in	mm							
ACBF2-2N	1/8	3.17	1/8	2.28	9/16	14.28	1/2	12.70	7/16	11.11	12.70	38.10	24.63	44.70	31.24	8.33	12.70
ACBF4-2N	1/4	6.35	1/8	4.82	5/8	15.87	5/8	15.87	9/16	14.28	15.24	39.62	26.16	46.99	33.52	11.50	10.16
ACBF4-4N	1/4	6.35	1/4	4.82	3/4	19.05	5/8	15.87	9/16	14.28	15.24	44.45	26.16	51.81	33.52	11.50	10.16
ACBF6-4N	3/8	9.52	1/4	7.11	3/4	19.05	3/4	19.05	11/16	17.46	16.76	47.75	29.46	55.11	36.83	14.68	11.17
ACBF6-6N	3/8	9.52	3/8	7.11	7/8	22.22	3/4	19.05	11/16	17.46	16.76	49.41	29.46	56.77	36.83	14.68	11.17
ACBF8-6N	1/2	12.70	3/8	10.41	15/16	23.81	15/16	23.81	7/8	22.22	22.86	51.56	31.75	61.72	41.91	19.44	12.70
ACBF8-8N	1/2	12.70	1/2	10.41	1-1/16	26.98	15/16	23.81	7/8	22.22	22.86	56.38	31.75	66.54	41.91	19.44	12.70
ACBF12-12N	3/4	19.05	3/4	15.74	1-1/4	31.75	1-3/16	30.16	1-1/8	28.57	24.38	63.60	38.30	73.51	47.21	25.79	16.76
ACBF16-16N	1	25.40	1	22.35	1-5/8	41.27	1-5/8	41.27	1-1/2	38.10	31.24	81.04	45.21	93.23	57.40	33.73	19.05
ACBF20-20N	1-1/4	31.75	1-1/4	27.68	1-7/8	47.63	1-7/8	47.63	1-7/8	47.63	41.14	83.49	47.75	105.59	69.85	41.67	19.05
ACBF24-24N	1-1/2	38.10	1-1/2	34.03	1-1/4	57.15	2-1/4	57.15	2-1/4	57.15	50.03	87.39	49.27	114.57	76.45	49.61	19.05
ACBF32-32N	2	50.80	2	45.97	1-3/4	69.85	2-3/4	69.85	3	76.20	67.56	95.30	56.38	132.63	93.71	57.94	19.05

Connects metric tube to male NPT thread

Part No.	Tube O.D. D	T (NPT)	O Min.	Width across flat			A	/	/1	L	L1	Panel Hole Drill size	Panel Max Thickness
				h	h1	H							
ACBF6M-2N	6	1/8	4.8	15.8	15.8	14	15.3	39.6	26.2	46.90	35.00	11.5	10.2
ACBF6M-4N	6	1/4	4.8	19.0	16.0	14	15.3	44.4	26.2	51.80	33.60	11.5	10.2
ACBF8M-4N	8	1/4	6.3	19.0	17.4	16	16.2	46.7	28.6	53.85	35.55	13.1	11.2
ACBF12M-8N	12	1/2	9.5	27.0	24.0	22	22.8	56.4	31.8	66.50	41.90	19.5	12.7

Female NPT Elbow

## ALF-N

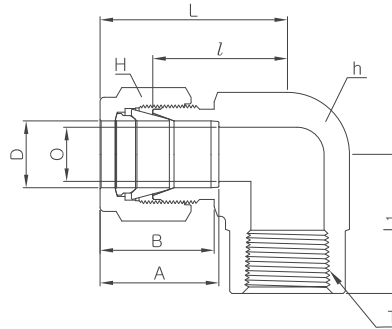
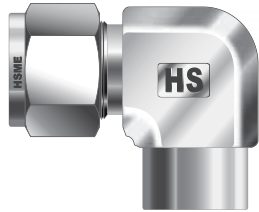

Connects fractional tube to male NPT thread

Part No.	Tube O.D.		T NPT	O Min.	Width across flat				A	B	/	L	L1
	D				h		H						
	in	mm			in	mm	in	mm					
ALF2-2N	1/8	3.17	1/8	2.28	1/2	12.70	7/16	11.11	12.70	15.24	18.03	24.63	19.05
ALF2-4N	1/8	3.17	1/4	2.28	11/16	17.46	7/16	11.11	12.70	15.24	20.82	27.43	22.35
ALF3-2N	3/16	4.76	1/8	3.04	1/2	12.70	1/2	12.70	13.71	16.00	18.79	25.40	19.05
ALF4-2N	1/4	6.35	1/8	4.82	1/2	12.70	9/16	14.28	15.24	17.78	19.55	26.92	19.05
ALF4-4N	1/4	6.35	1/4	4.82	11/16	17.46	9/16	14.28	15.24	17.78	22.35	29.71	22.35
ALF4-6N	1/4	6.35	3/8	4.82	13/16	20.64	9/16	14.28	15.24	17.78	24.38	31.75	22.35
ALF4-8N	1/4	6.35	1/2	4.82	1	25.40	9/16	14.28	15.24	17.78	27.17	34.54	28.44
ALF5-2N	5/16	7.93	1/8	6.35	9/16	14.28	5/8	15.87	16.25	18.54	21.33	28.70	19.05
ALF5-4N	5/16	7.93	1/4	6.35	11/16	17.46	5/8	15.87	16.25	18.54	23.11	30.48	22.35
ALF6-2N	3/8	9.52	1/8	7.11	5/8	15.87	11/16	17.46	16.76	19.30	23.11	30.48	19.05
ALF6-4N	3/8	9.52	1/4	7.11	11/16	17.46	11/16	17.46	16.76	19.30	23.87	31.24	22.35
ALF6-6N	3/8	9.52	3/8	7.11	13/16	20.64	11/16	17.46	16.76	19.30	25.90	33.27	22.35
ALF6-8N	3/8	9.52	1/2	7.11	1	25.40	11/16	17.46	16.76	19.30	28.70	36.06	28.44
ALF8-4N	1/2	12.70	1/4	10.41	13/16	20.64	7/8	22.22	22.86	21.84	25.90	36.06	22.35
ALF8-6N	1/2	12.70	3/8	10.41	13/16	20.64	7/8	22.22	22.86	21.84	25.90	36.06	22.35
ALF8-8N	1/2	12.70	1/2	10.41	1	25.40	7/8	22.22	22.86	21.84	28.70	38.86	28.44
ALF10-6N	5/8	15.87	3/8	12.70	15/16	23.81	1	25.40	24.38	21.84	27.94	38.10	22.35
ALF10-8N	5/8	15.87	1/2	12.70	1	25.40	1	25.40	24.38	21.84	29.71	39.87	28.44
ALF12-8N	3/4	19.05	1/2	15.74	1-1/16	26.98	1-1/8	28.58	24.38	21.84	29.71	39.87	28.44
ALF12-12N	3/4	19.05	3/4	15.74	1-3/8	34.92	1-1/8	28.58	24.38	21.84	34.54	44.70	31.75
ALF14-12N	7/8	22.22	3/4	18.28	1-3/8	34.92	1-1/4	31.75	25.90	21.84	34.54	44.70	31.75
ALF16-12N	1	25.40	3/4	22.35	1-3/8	34.92	1-1/2	38.10	31.24	26.41	36.83	49.02	31.75
ALF16-16N	1	25.40	1	22.35	1-11/16	42.86	1-1/2	38.10	31.24	26.41	41.40	50.29	38.10

Connects metric tube to male NPT thread

Part No.	Tube O.D. D	T (NPT)	O Min.	Width across flat		A	B	/	L	L1
				h	H					
ALF6M-2N	6	1/8	4.8	12.70	14	15.3	17.7	19.6	27.0	19.00
ALF6M-4N	6	1/4	4.8	17.46	14	15.3	17.7	22.4	29.8	22.40
ALF6M-6N	6	3/8	4.8	20.64	14	15.3	17.7	24.4	31.7	22.40
ALF6M-8N	6	1/2	4.8	25.40	14	15.3	17.7	27.2	34.6	28.40
ALF8M-2N	8	1/8	6.4	15.87	16	16.2	18.6	23.1	29.9	19.00
ALF8M-4N	8	1/4	6.4	17.46	16	16.2	18.6	23.1	30.6	22.40
ALF8M-8N	8	1/2	6.4	25.40	16	16.2	18.6	28.0	35.2	28.40
ALF10M-2N	10	1/8	7.9	17.46	19	17.2	19.5	23.9	31.5	19.00
ALF10M-4N	10	1/4	7.9	17.46	19	17.2	19.5	25.9	33.5	22.35
ALF10M-6N	10	3/8	7.9	20.64	19	17.2	19.5	25.9	33.5	22.40
ALF10M-8N	10	1/2	7.9	25.40	19	17.2	19.5	28.7	36.1	28.40
ALF12M-4N	12	1/4	9.5	20.64	22	22.8	22.0	25.9	36.0	22.40
ALF12M-6N	12	3/8	9.5	20.64	22	22.8	22.0	25.9	36.2	22.35
ALF12M-8N	12	1/2	9.5	25.40	22	22.8	22.0	28.7	38.8	28.40
ALF16M-8N	16	1/2	12.7	26.98	25	24.4	22.0	29.7	39.5	28.40

Female NPT Run Tee  
**ATRF-N**

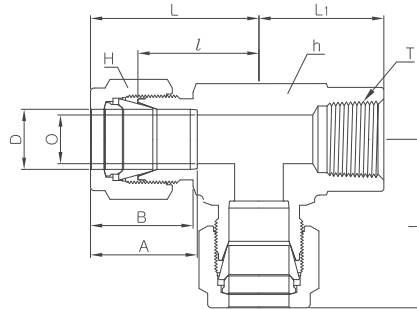
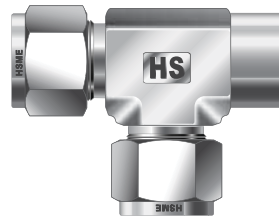

Connects fractional tube to male NPT thread

Part No.	Tube O.D. D		T NPT	O Min.	Width across flat				A	B	/	L	L1
	in	mm			h		H						
					in	mm	in	mm					
ATRF2-2N	1/8	3.17	1/8	2.28	1/2	12.70	7/16	11.11	12.70	15.24	18.03	24.63	19.05
ATRF 2-4N	1/8	3.17	1/4	2.28	11/16	17.46	7/16	11.11	12.70	15.24	20.82	27.43	22.35
ATRF 3-2N	3/16	4.76	1/8	3.04	1/2	12.70	1/2	12.70	13.71	16.00	18.79	25.40	19.05
ATRF4-2N	1/4	6.35	1/8	4.82	1/2	12.70	9/16	14.28	15.24	17.78	19.55	26.92	19.05
ATRF4-4N	1/4	6.35	1/4	4.82	11/16	17.46	9/16	14.28	15.24	17.78	22.86	29.71	22.35
ATRF4-6N	1/4	6.35	3/8	4.82	13/16	20.64	9/16	14.28	15.24	17.78	24.38	31.75	22.35
ATRF4-8N	1/4	6.35	1/2	4.82	1	25.40	9/16	14.28	15.24	17.78	27.17	34.54	28.44
ATRF5-2N	5/16	7.94	1/8	6.35	9/16	14.28	5/8	15.87	16.25	18.54	21.33	28.70	19.05
ATRF5-4N	5/16	7.94	1/4	6.35	11/16	17.46	5/8	15.87	16.25	18.54	23.11	30.48	22.35
ATRF6-2N	3/8	9.52	1/8	7.11	5/8	15.87	11/16	17.46	16.76	19.30	23.11	30.48	19.05
ATRF6-4N	3/8	9.52	1/4	7.11	11/16	17.46	11/16	17.46	16.76	19.30	23.87	31.24	22.35
ATRF6-6N	3/8	9.52	3/8	6.35	13/16	20.64	11/16	17.46	16.76	19.30	25.90	33.27	22.35
ATRF6-8N	3/8	9.52	1/2	7.11	1	25.40	11/16	17.46	16.76	19.30	28.70	36.06	28.44
ATRF8-4N	1/2	12.70	1/4	10.41	13/16	20.64	7/8	22.22	22.86	21.84	25.90	36.06	22.35
ATRF8-6N	1/2	12.70	3/8	10.41	13/16	20.64	7/8	22.22	22.86	21.84	25.90	36.06	22.35
ATRF8-8N	1/2	12.70	1/2	10.41	1	25.40	7/8	22.22	22.86	21.84	29.71	39.87	28.44
ATRF10-6N	5/8	15.87	3/8	12.70	15/16	23.81	1	25.40	24.38	21.84	27.94	38.10	22.35
ATRF10-8N	5/8	15.87	1/2	12.70	1	25.40	1	25.40	24.38	21.84	29.71	38.86	28.44
ATRF12-8N	3/4	19.05	1/2	15.74	1-1/16	26.98	1-1/8	28.58	24.38	21.84	29.71	39.87	28.44
ATRF12-12N	3/4	19.05	3/4	15.74	1-3/8	34.92	1-1/8	28.58	24.38	21.84	34.54	44.70	31.75
ATRF14-12N	7/8	22.22	3/4	18.28	1-3/8	34.92	1-1/4	31.75	31.75	21.84	34.54	44.70	31.75
ATRF16-12N	1	25.40	3/4	22.35	1-3/8	34.92	1-1/2	38.10	38.10	26.41	36.83	49.02	31.75
ATRF16-16N	1	25.40	1	22.35	1-1/16	42.86	1-1/2	38.10	38.10	26.41	41.40	50.29	38.10

Connects metric tube to male NPT thread

Part No.	Tube O.D. D	T (NPT)	O Min.	Width across flat		A	B	/	L	L1
				h	H					
ATRF6M-2N	6	1/8	4.8	12.70	14	15.3	17.7	19.6	27.0	19.00
ATRF6M-4N	6	1/4	4.8	17.46	14	15.3	17.7	22.4	29.8	22.40
ATRF6M-6N	6	3/8	4.8	20.64	14	15.3	17.7	24.4	31.7	22.40
ATRF6M-8N	6	1/2	4.8	25.40	14	15.3	17.7	27.2	34.5	28.40
ATRF8M-2N	8	1/8	6.4	15.87	16	16.2	18.6	23.1	29.9	19.00
ATRF8M-4N	8	1/4	6.4	17.46	16	16.2	18.6	23.1	30.6	22.40
ATRF8M-6N	8	3/8	6.4	20.64	16	16.2	18.6	25.2	32.4	22.40
ATRF8M-8N	8	1/2	6.4	25.40	16	16.2	18.6	28.0	35.2	28.40
ATRF10M-2N	10	1/8	7.9	20.64	19	17.2	19.5	23.9	31.5	19.00
ATRF10M-4N	10	1/4	7.9	20.64	19	17.2	19.5	25.9	33.6	22.40
ATRF10M-6N	10	3/8	7.9	20.64	19	17.2	19.5	25.9	33.6	22.40
ATRF10M-8N	10	1/2	7.9	25.40	19	17.2	19.5	26.2	33.6	28.40
ATRF12M-4N	12	1/4	9.5	20.64	22	22.8	22.0	25.9	36.0	22.40
ATRF12M-6N	12	3/8	9.5	20.64	22	22.8	22.0	25.9	36.0	22.40
ATRF12M-8N	12	1/2	9.5	25.40	22	22.8	22.0	29.7	40.0	28.40
ATRF16M-8N	16	1/2	12.7	25.40	25	24.4	22.0	29.7	39.5	28.40

## Female NPT Branch Tee **ATBF-N**

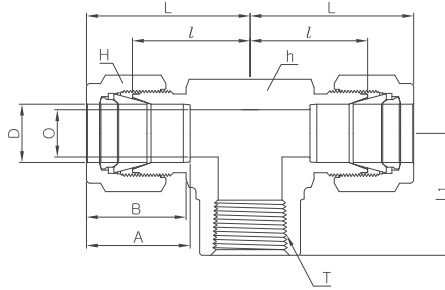
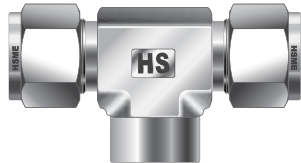

Connects fractional tube to male NPT thread

Part No.	Tube O.D. D		T NPT	O Min.	Width across flat				A	B	/	L	L1
	in	mm			h		H						
					in	mm	in	mm					
ATBF2-2N	1/8	3.17	1/8	2.28	1/2	12.70	7/16	11.11	12.70	15.24	18.03	24.38	19.05
ATBF2-4N	1/8	3.17	1/4	2.28	11/16	17.46	7/16	11.11	12.70	15.24	20.82	27.43	22.35
ATBF3-2N	3/16	4.76	1/8	3.04	1/2	12.70	1/2	12.70	13.71	16.00	18.79	25.40	19.05
ATBF4-2N	1/4	6.35	1/8	4.82	1/2	12.70	9/16	14.28	15.24	17.78	19.55	26.92	19.05
ATBF4-4N	1/4	6.35	1/4	4.82	11/16	17.46	9/16	14.28	15.24	17.78	22.35	29.71	22.35
ATBF4-6N	1/4	6.35	3/8	4.82	13/16	20.64	9/16	14.28	15.24	17.78	24.38	31.75	22.35
ATBF4-8N	1/4	6.35	1/2	4.82	1	25.40	9/16	14.28	15.24	17.78	27.17	34.54	28.44
ATBF5-2N	5/16	7.94	1/8	6.35	9/16	14.28	5/8	15.87	16.25	18.54	21.33	28.70	19.05
ATBF5-4N	5/16	7.94	1/4	6.35	11/16	17.46	5/8	15.87	16.25	18.54	23.11	30.48	22.35
ATBF6-2N	3/8	9.52	1/8	7.11	5/8	15.87	11/16	17.46	16.76	19.30	23.11	30.48	19.05
ATBF6-4N	3/8	9.52	1/4	7.11	11/16	17.46	11/16	17.46	16.76	19.30	23.87	31.24	22.35
ATBF6-6N	3/8	9.52	3/8	6.35	13/16	20.64	11/16	17.46	16.76	19.30	25.90	33.27	22.35
ATBF6-8N	3/8	9.52	1/2	7.11	1	25.40	11/16	17.46	16.76	19.30	28.70	36.06	28.44
ATBF8-4N	1/2	12.70	1/4	10.41	13/16	20.64	7/8	22.22	22.86	21.84	25.90	36.06	22.35
ATBF8-6N	1/2	12.70	3/8	10.41	13/16	20.64	7/8	22.22	22.86	21.84	25.90	36.06	22.35
ATBF8-8N	1/2	12.70	1/2	10.41	1	25.40	7/8	22.22	22.86	21.84	29.71	39.87	28.44
ATBF10-6N	5/8	15.87	3/8	12.70	15/16	23.81	1	25.40	24.38	21.84	27.94	38.10	22.35
ATBF10-8N	5/8	15.87	1/2	12.70	1	25.40	1	25.40	24.38	21.84	28.70	38.86	28.44
ATBF12-8N	3/4	19.05	1/2	15.74	1-1/16	26.98	1-1/8	28.58	24.38	21.84	29.71	39.87	28.44
ATBF12-12N	3/4	19.05	3/4	15.74	1-3/8	34.92	1-1/8	28.58	24.38	21.84	34.54	44.70	31.75
ATBF14-12N	7/8	22.22	3/4	18.28	1-3/8	34.92	1-1/4	31.75	25.90	21.84	34.54	44.70	31.75
ATBF16-12N	1	25.40	3/4	22.35	1-3/8	34.92	1-1/2	38.10	31.24	26.41	36.83	49.02	31.75
ATBF16-16N	1	25.40	1	22.35	1-11/16	42.86	1-1/2	38.10	31.24	26.41	41.40	53.59	38.10

Connects metric tube to male NPT thread

Part No.	Tube O.D. D	T (NPT)	O Min.	Width across flat		A	B	/	L	L1
				h	H					
ATBF6M-2N	6	1/8	4.8	12.70	14	15.3	17.7	19.6	27.0	19.00
ATBF6M-4N	6	1/4	4.8	17.46	14	15.3	17.7	22.4	29.8	22.40
ATBF6M-6N	6	3/8	4.8	20.64	14	15.3	17.7	24.4	31.7	22.40
ATBF6M-8N	6	1/2	4.8	25.40	14	15.3	17.7	27.2	34.5	28.40
ATBF8M-2N	8	1/8	6.4	15.87	16	16.2	18.6	23.1	29.9	19.00
ATBF8M-4N	8	1/4	6.4	17.46	16	16.2	18.6	23.1	30.6	22.40
ATBF8M-6N	8	3/8	6.4	20.64	16	16.2	18.6	25.2	32.4	22.40
ATBF8M-8N	8	1/2	6.4	25.40	16	16.2	18.6	28.0	35.2	28.40
ATBF10M-2N	10	1/8	7.9	17.50	19	17.2	19.5	23.9	31.5	19.00
ATBF10M-4N	10	1/4	7.9	20.64	19	17.2	19.5	25.9	33.6	22.40
ATBF10M-6N	10	3/8	7.9	20.64	19	17.2	19.5	25.9	33.5	22.40
ATBF10M-8N	10	1/2	9.5	25.40	19	17.2	19.5	26.2	33.6	22.40
ATBF12M-4N	12	1/4	9.5	20.64	22	22.8	22.0	25.9	36.0	22.40
ATBF12M-6N	12	3/8	9.5	20.64	22	22.8	22.0	25.9	36.0	22.40
ATBF12M-8N	12	1/2	9.5	25.40	22	22.8	22.0	29.7	40.0	28.40
ATBF16M-8N	16	1/2	12.7	25.40	25	24.4	22.0	29.7	40.0	28.70

• Port Connector  
**ACP**

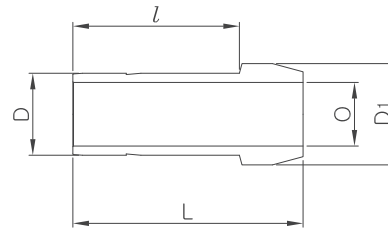

Connects fractional M Tube fitting® ports

Part No.	Tube O.D. D		O Min.	D1	l	L
	in	mm				
ACP-1	1/16	1.59	1.00	3.30	10.66	13.72
ACP-2	1/8	3.17	1.77	6.09	15.75	22.35
ACP-4	1/4	6.35	4.57	9.39	18.79	24.64
ACP-5	5/16	7.93	6.35	10.92	20.06	25.90
ACP-6	3/8	9.52	7.11	12.70	20.32	26.16
ACP-8	1/2	12.70	9.90	15.74	25.90	35.81
ACP-12	3/4	19.05	14.98	22.09	27.68	37.33
ACP-16	1	25.40	20.06	28.44	34.54	48.00

Connects metric M Tube fitting® ports

Part No.	Tube O.D. D	O Min.	D1	l	L
ACP-3M	3	2.1	6.0	15.70	22.20
ACP-4M	4	2.2	7.0	16.67	25.81
ACP-6M	6	4.4	9.0	18.70	24.60
ACP-8M	8	6.2	11.0	20.00	25.90
ACP-10M	10	8.2	13.1	20.20	26.10
ACP-12M	12	9.1	15.0	26.00	35.80
ACP-15M	15	12.7	19.0	27.78	37.40
ACP-16M	16	12.7	19.0	27.60	37.40
ACP-18M	18	13.9	21.0	27.91	37.40
ACP-20M	20	15.1	23.0	29.20	38.90
ACP-22M	22	17.9	24.97	29.30	39.20
ACP-25M	25	19.8	28.0	34.50	48.00
ACP-28M	28	23.8	34.3	48.30	63.50
ACP-32M	32	27.4	39.5	52.40	69.70
ACP-38M	38	33.3	47.1	61.40	81.90

**Port Connector**

Apply port connector where two tube ports are required close connection.

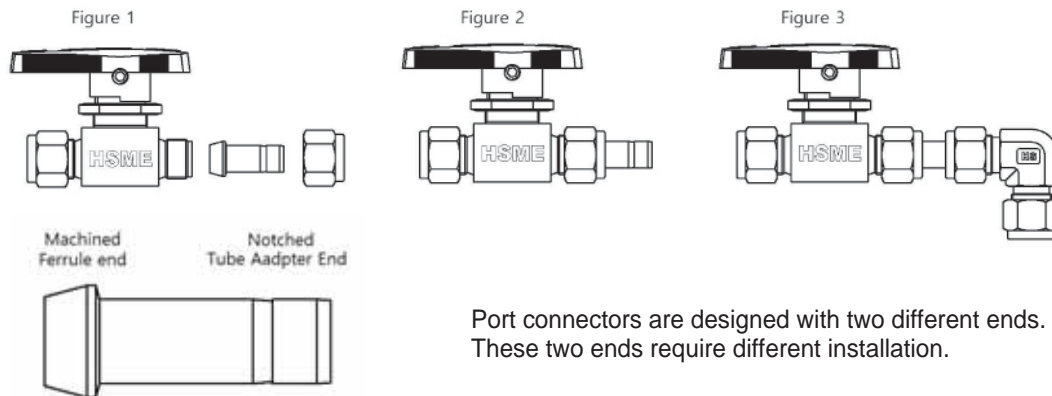

Port connectors are designed with two different ends. These two ends require different installation.

**Installation Instruction**

**Machined Ferrule End**

1. Gently insert machined ferrule end into the tube port. (Figure 1)
2. Place nut only over the machined ferrule. (Figure 1)
3. Finger tighten the nut. (Figure 2)
4. Wrench-tighten the nut 1/4 turn beyond the finger-tight position. (Figure 2)

**Tube Adapter End**

1. Insert tube adapter end into the M Tube fitting. (Figure 3)
2. Follow M tube fitting's standard installation instruction. (Figure 3)

# M Tube Fittings®

## Reducing Port Connector ACPR

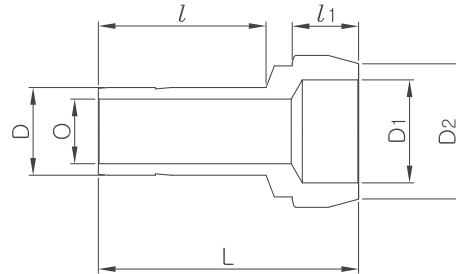
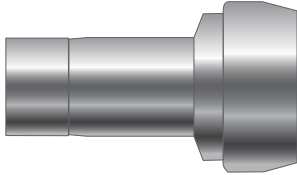

Connects fractional M Tube fitting® ports

Part No.	Tube O.D.				O Min.	D2	l	l1	L
	D1		D						
	in	mm	in	mm					
ACPR2-1	1/8	3.17	1/16	1.59	1.00	6.10	8.64	2.03	17.27
ACPR4-2	1/4	6.35	1/8	3.17	2.28	9.39	13.45	3.30	22.60
ACPR6-2	3/8	9.52	1/8	3.17	2.28	12.70	13.45	3.81	23.11
ACPR6-4	3/8	9.52	1/4	6.35	4.82	12.70	15.75	3.30	24.89
ACPR8-4	1/2	12.70	1/4	6.35	4.82	15.74	15.75	3.81	29.21
ACPR8-6	1/2	12.70	3/8	9.52	7.11	15.74	17.67	3.30	30.48
ACPR12-8	3/4	19.05	1/2	12.70	9.90	22.09	23.20	3.81	37.85
ACPR16-8	1	25.40	1/2	12.70	9.90	28.40	24.47	4.82	42.67
ACPR16-12	1	25.40	3/4	19.05	14.98	28.40	25.90	4.06	43.43

Connects metric M Tube fitting® ports

Part No.	Tube O.D.		O Min.	D2	l	l1	L
	D1	D					
ACPR6M-3M	6	3	2.2	9.0	13.50	3.2	22.60
ACPR8M-6M	8	6	4.6	11.0	15.70	3.1	24.70
ACPR10M-6M	10	6	4.6	13.1	15.70	3.4	25.00
ACPR10M-8M	10	8	6.4	13.1	16.80	3.1	26.00
ACPR12M-6M	12	6	4.6	15.0	15.70	3.6	29.10
ACPR12M-8M	12	8	6.4	15.0	16.80	3.4	29.80
ACPR12M-10M	12	10	7.7	15.0	17.50	3.1	30.40
ACPR16M-6M	16	6	4.6	19.0	15.75	3.6	30.40
ACPR16M-12M	16	12	9.1	19.0	23.10	3.4	36.20
ACPR28M-25M	28	25	19.8	34.3	33.00	8.2	56.50
ACPR32M-25M	32	25	19.8	39.5	33.00	9.9	60.30
ACPR38M-25M	38	25	19.8	47.1	33.00	12.3	65.80

## Port Reducer

Solution for reducing the Port OD size of an existing port.

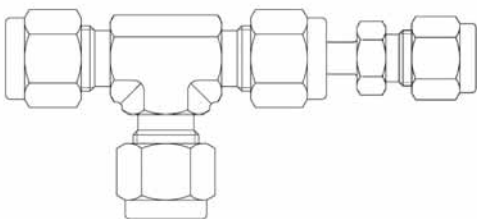

By using the port reducer, you may reduce an existing M Tube Fitting Port OD size.

• Port Reducer  
**AR**

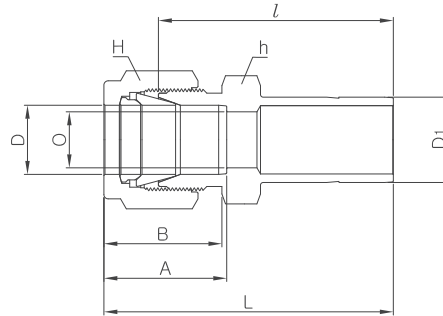
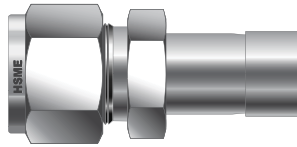

Connects fractional tube to fractional M Tube fitting® port

Part No.	Tube O.D.				O Min.	Width across flat				A	B	/	L
	D		D1			h		H					
	in	mm	in	mm		in	mm	in	mm				
AR1-2	1/16	1.59	1/8	3.17	1.27	5/16	7.93	5/16	7.93	8.63	10.92	25.40	29.21
AR1-4	1/16	1.59	1/4	6.35	1.27	5/16	7.93	5/16	7.93	8.63	10.92	27.68	31.49
AR2-1	1/8	3.17	1/16	1.59	1.76	7/16	11.11	7/16	11.11	12.70	15.24	22.35	28.95
AR2-2	1/8	3.17	1/8	3.17	2.03	7/16	11.11	7/16	11.11	12.70	15.24	26.92	33.52
AR2-3	1/8	3.17	3/16	4.76	2.28	7/16	11.11	7/16	11.11	12.70	15.24	27.68	34.29
AR2-4	1/8	3.17	1/4	6.35	2.28	7/16	11.11	7/16	11.11	12.70	15.24	29.46	36.06
AR2-6	1/8	3.17	3/8	9.52	2.28	7/16	11.11	7/16	11.11	12.70	15.24	30.98	37.59
AR2-8	1/8	3.17	1/2	12.70	2.28	9/16	14.28	7/16	11.11	12.70	15.24	37.59	44.19
AR3-2	3/16	4.76	1/8	3.17	2.03	7/16	11.11	1/2	12.70	13.71	16.00	28.19	34.79
AR3-4	3/16	4.76	1/4	6.35	3.04	7/16	11.11	1/2	12.70	13.71	16.00	30.48	37.08
AR4-2	1/4	6.35	1/8	3.17	2.03	1/2	12.70	9/16	14.28	15.24	17.78	29.46	36.83
AR4-3	1/4	6.35	3/16	4.76	3.04	1/2	12.70	9/16	14.28	15.24	17.78	30.22	37.59
AR4-4	1/4	6.35	1/4	6.35	4.82	1/2	12.70	9/16	14.28	15.24	17.78	31.75	39.11
AR4-5	1/4	6.35	5/16	7.93	4.82	1/2	12.70	9/16	14.28	15.24	17.78	32.51	39.87
AR4-6	1/4	6.35	3/8	9.52	4.82	1/2	12.70	9/16	14.28	15.24	17.78	33.27	40.64
AR4-8	1/4	6.35	1/2	12.70	4.82	9/16	14.28	9/16	14.28	15.24	17.78	38.86	46.22
AR4-10	1/4	6.35	5/8	15.87	4.82	11/16	17.46	9/16	14.28	15.24	17.78	40.64	48.00
AR4-12	1/4	6.35	3/4	19.05	4.82	13/16	20.64	9/16	14.28	15.24	17.78	40.38	47.75
AR5-6	5/16	7.93	3/8	9.52	6.35	9/16	14.28	5/8	15.87	16.25	18.54	34.54	41.91
AR5-8	5/16	7.93	1/2	12.70	6.35	9/16	14.28	5/8	15.87	16.25	18.54	40.13	47.49
AR6-4	3/8	9.52	1/4	6.35	4.82	5/8	15.87	11/16	17.46	16.76	19.30	34.03	41.40
AR6-6	3/8	9.52	3/8	9.52	7.11	5/8	15.87	11/16	17.46	16.76	19.30	35.81	43.18
AR6-8	3/8	9.52	1/2	12.70	7.11	5/8	15.87	11/16	17.46	16.76	19.30	41.14	45.81
AR6-10	3/8	9.52	5/8	15.87	7.11	11/16	17.46	11/16	17.46	16.76	19.30	42.92	50.29
AR6-12	3/8	9.52	3/4	19.05	7.11	13/16	20.64	11/16	17.46	16.76	19.30	42.92	50.29
AR8-4	1/2	12.70	1/4	6.35	4.82	13/16	20.64	7/8	22.22	22.86	21.84	34.79	44.95
AR8-6	1/2	12.70	3/8	9.52	7.11	13/16	20.64	7/8	22.22	22.86	21.84	36.57	46.73
AR8-8	1/2	12.70	1/2	12.70	9.90	13/16	20.64	7/8	22.22	22.86	21.84	42.16	52.32
AR8-10	1/2	12.70	5/8	15.87	10.41	13/16	20.64	7/8	22.22	22.86	21.84	43.68	53.84
AR8-12	1/2	12.70	3/4	19.05	10.41	13/16	20.64	7/8	22.22	22.86	21.84	43.68	53.84
AR8-16	1/2	12.70	1	25.40	10.41	1-1/16	26.98	7/8	22.22	22.86	21.84	50.03	60.19
AR10-12	5/8	15.87	3/4	19.05	12.70	15/16	23.81	1	25.40	24.38	21.84	44.45	54.61
AR10-14	5/8	15.87	7/8	22.22	12.70	15/16	23.81	1	25.40	24.38	21.84	45.97	56.13
AR10-16	5/8	15.87	1	25.40	12.70	1-1/16	26.98	1	25.40	24.38	21.84	50.80	60.96
AR12-8	3/4	19.05	1/2	12.70	9.90	1-1/16	26.98	1-1/8	28.57	24.38	21.84	44.45	54.61
AR12-16	3/4	19.05	1	25.40	15.74	1-1/16	26.98	1-1/8	28.57	24.38	21.84	52.32	62.48
AR16-20	1	25.40	1-1/4	31.75	22.35	1-3/8	34.93	1-1/2	38.10	31.24	26.41	68.32	80.51
AR16-24	1	25.40	1-1/2	38.10	22.35	1-5/8	41.28	1-1/2	38.10	31.24	26.41	76.96	89.15
AR16-32	1	25.40	2	50.80	22.35	2-1/8	53.98	1-1/2	38.10	31.24	26.41	100.33	112.52
AR20-24	1-1/4	31.75	1-1/2	38.10	27.68	1-7/8	47.63	1-7/8	57.15	41.14	38.86	82.04	104.14
AR20-32	1-1/4	31.75	2	50.80	27.68	1-7/8	47.63	1-7/8	76.20	41.14	38.86	103.12	125.22
AR24-32	1-1/2	38.10	2	50.80	34.03	2-1/4	57.15	2-1/4	76.20	50.03	45.21	104.14	131.31

# M Tube Fittings®

## Port Reducer

### AR

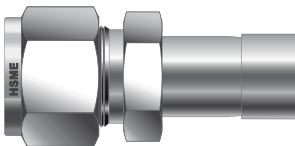
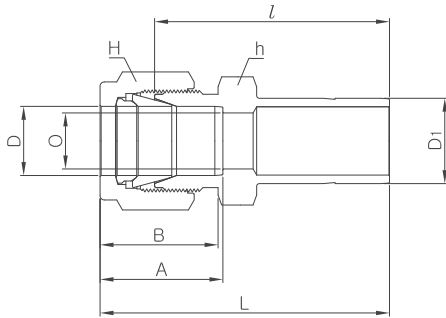

Connects metric tube to fractional M Tube fitting® port

Part No.	Tube O.D.			O Min.	Width across flat		A	B	/	L
	D	D1			h	H				
		in	mm							
AR2M-2	2	1/8	3.17	1.7	12	12	12.9	15.3	26.9	33.5
AR3M-2										
AR3M-4	3	1/4	6.35	2.4	12	12	12.9	15.3	29.5	36.1
AR4M-4										
AR6M-2	6	1/8	3.18	2.0	14	14	15.3	17.7	29.5	36.9
AR6M-4										
AR6M-5	6	5/16	7.93	4.8	14	14	15.3	17.7	32.5	39.9
AR6M-6										
AR6M-8	6	1/2	12.70	4.8	14	14	15.3	17.7	38.9	46.3
AR8M-6										
AR8M-8	8	1/2	12.70	6.4	15	16	16.2	18.6	40.1	47.6
AR10M-6										
AR10M-8	10	1/2	12.70	7.9	18	19	17.2	19.5	42.2	49.8
AR12M-8										
AR12M-12	12	3/4	19.05	9.5	22	22	22.8	22.0	43.7	53.8
AR18M-12										
AR18M-16	18	1	25.40	15.1	27	30	24.4	22.0	52.3	62.4
AR25M-16	25	1	25.40	20.2	35	38	31.3	26.5	57.2	69.5

Connects metric tube to metric M Tube fitting® port

Part No.	Tube O.D.		O Min.	Width across flat		A	B	/	L
	D1	D		h	H				
AR3M-4M	3	4	2.4	12	12	12.9	15.3	28.4	35.0
AR3M-6M	3	6	2.4	12	12	12.9	15.3	29.5	36.1
AR3M-10M	3	10	2.4	12	12	12.9	15.3	31.8	38.4
AR4M-6M	4	6	2.4	12	12	13.7	16.1	30.5	37.1
AR6M-3M	6	3	1.8	14	14	15.3	17.7	29.5	36.9
AR6M-8M	6	8	4.8	14	14	15.3	17.7	32.5	39.9
AR6M-10M	6	10	4.8	14	14	15.3	17.7	33.3	40.7
AR6M-12M	6	12	4.8	14	14	15.3	17.7	38.9	46.3
AR8M-6M	8	6	4.6	15	16	16.2	18.6	32.8	40.3
AR8M-10M	8	10	6.4	15	16	16.2	18.6	34.5	42.0
AR8M-12M	8	12	6.4	15	16	16.2	18.6	40.1	47.6
AR10M-6M	10	6	4.6	18	19	17.2	19.5	34.8	42.4
AR10M-12M	10	12	7.9	18	19	17.2	19.5	42.2	49.8
AR10M-15M	10	15	7.9	18	19	17.2	19.5	43.7	51.3
AR10M-18M	10	18	7.9	19	19	17.2	19.5	43.7	51.3
AR12M-6M	12	6	4.6	22	22	22.8	22.0	34.8	44.9
AR12M-10M	12	10	7.7	22	22	22.8	22.0	36.6	46.7
AR12M-16M	12	16	9.5	22	22	22.8	22.0	43.7	53.8
AR12M-18M	12	18	9.5	22	22	22.8	22.0	43.7	53.8
AR12M-20M	12	20	9.5	22	22	22.8	22.0	46.0	56.1
AR12M-22M	12	22	9.5	24	22	22.8	22.0	46.0	56.1
AR12M-25M	12	25	9.5	27	22	22.8	22.0	52.3	62.4
AR16M-12M	16	12	9.1	24	25	24.4	22.0	42.9	53.0
AR18M-12M	18	12	9.1	27	30	24.4	22.0	44.5	54.6
AR18M-16M	18	16	12.7	27	30	24.4	22.0	46.0	56.1
AR18M-20M	18	20	15.1	27	30	24.4	22.0	47.5	57.6
AR18M-22M	18	22	15.1	27	30	24.4	22.0	47.5	57.6
AR18M-25M	18	25	15.1	27	30	24.4	22.0	52.3	62.4
AR20M-16M	20	16	12.7	30	32	26.0	22.0	47.8	57.9
AR20M-18M	20	18	13.9	30	32	26.0	22.0	47.8	57.9
AR20M-22M	20	22	15.8	30	32	26.0	22.0	49.3	59.4
AR20M-25M	20	25	15.8	30	32	26.0	22.0	54.1	64.2
AR22M-18M	22	18	13.9	30	32	26.0	22.0	47.8	57.9
AR22M-20M	22	20	15.1	30	32	26.0	22.0	49.3	59.4
AR22M-25M	22	25	18.3	30	32	26.0	22.0	54.1	64.2
AR25M-18M	25	18	13.9	35	38	31.3	26.5	50.8	63.1
AR25M-20M	25	20	15.1	35	38	31.3	26.5	52.3	64.6



Bulkhead Tube Adapter  
**AAB**

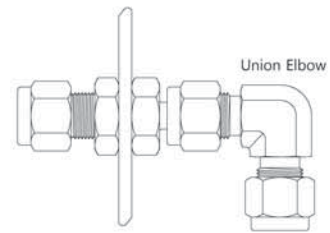
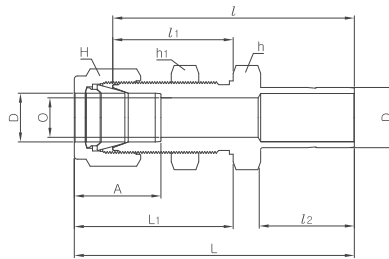
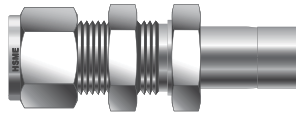

Bulkhead adapter helps set a direction through panel

Connects fractional tube to fractional M Tube fitting® port

Part No.	Tube O.D. D		O Min.	Width across flat				A	I	I1	I2	L	L1	Panel Hole Drill size	Panel Max Thickness
	in	mm		h		H									
AAB2-2	1/8	3.17	2.03	1/2	12.70	7/16	11.11	12.70	42.92	24.63	13.45	49.53	31.24	8.33	12.70
AAB4-4	1/4	6.35	4.82	5/8	15.87	9/16	14.28	15.24	48.51	26.16	15.74	55.88	33.52	11.50	10.16
AAB6-6	3/8	9.52	7.11	3/4	19.05	11/16	17.46	16.76	53.84	29.46	17.50	61.21	36.83	14.68	11.17
AAB8-8	1/2	12.70	10.41	15/16	23.81	7/8	22.22	22.86	62.73	31.75	23.11	72.89	41.91	19.44	12.70
AAB10-10	5/8	15.87	12.70	1-1/16	26.98	1	25.40	24.38	65.02	32.51	24.70	75.18	42.67	22.62	12.70
AAB16-16	1	25.40	20.32	1-5/8	41.28	1-1/2	38.10	31.24	88.13	45.21	31.70	100.33	57.40	33.73	19.05
AAB20-20	1-1/4	31.75	27.68	1-7/8	47.63	1-7/8	47.63	41.14	102.07	47.75	40.00	124.17	69.85	41.67	19.05
AAB24-24	1-1/2	38.10	34.03	2-1/4	57.15	2-1/4	57.15	50.03	118.33	49.27	51.50	145.51	76.45	49.61	19.05
AAB32-32	2	50.80	45.97	2-3/4	69.85	3	76.20	67.56	148.79	56.38	68.40	185.82	93.71	57.94	19.05

Elbow Tube Adapter  
**ALA**

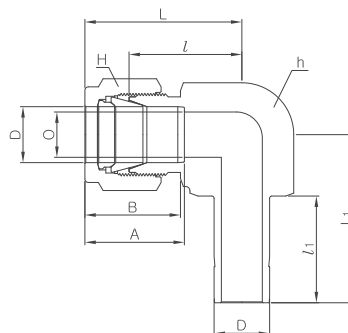

Connects fractional tube to fractional M Tube Fitting® port.

Part No.	Tube O.D. D		O Min.	Width across flat				A	B	I	I1	L	L1
	in	mm		h		H							
ALA-4	1/4	6.35	4.8	1/2	12.70	9/16	14.28	15.24	17.78	19.55	15.75	27.0	25.00
ALA-6	3/8	9.52	7.10	5/8	15.87	11/16	17.46	16.76	19.30	23.11	17.50	31.5	29.10
ALA-8	1/2	12.70	10.41	13/16	20.63	7/8	22.22	22.86	21.84	25.90	23.10	36.0	37.3
ALA-12	3/4	19.05	16.00	1-1/16	26.98	1-1/8	28.57	24.38	21.84	29.71	24.70	38.8	42.6
ALA-16	1	25.40	22.30	1-3/8	34.92	1-1/2	38.10	31.24	26.41	46.83	31.70	42.6	54.40

Connects metric tube to metric M Tube fitting® port

Part No.	Tube O.D. D	O Min.	Width across flat		A	B	I	I1	L	L1
			h	H						
ALA-6M	6	4.6	12.7	14	15.3	17.7	19.6	15.7	27.0	25.0
ALA-8M	8	6.4	15.8	16	16.2	18.6	21.3	16.8	28.8	27.05
ALA-10M	10	7.7	17.4	19	17.2	19.5	23.9	17.5	31.5	30.0
ALA-12M	12	9.1	20.6	22	22.8	22.0	25.9	23.1	36.0	37.3
ALA-14M	14	11.1	25.4	25	24.4	22.0	28.7	24.6	38.8	41.5
ALA-15M	15	11.9	25.4	25	24.4	22.0	28.7	24.65	38.8	41.55
ALA-16M	16	12.7	25.4	25	24.4	22.0	28.7	24.6	38.8	41.5
ALA-18M	18	13.9	26.9	30	24.4	22.0	29.7	24.6	39.8	42.5
ALA-20M	20	15.1	31.8	32	26.0	22.0	32.5	26.2	42.6	47.0
ALA-22M	22	18.3	31.8	32	26.0	22.0	32.5	26.6	42.6	47.15
ALA-25M	25	19.8	34.9	38	31.3	26.5	36.8	31.7	49.1	55.2
ALA-28M	28	21.8	41.0	46	36.6	36.6	43.2	37.5	64.0	64.9

# M Tube Fittings®

## Run Tee Tube Adapter **ATRA**

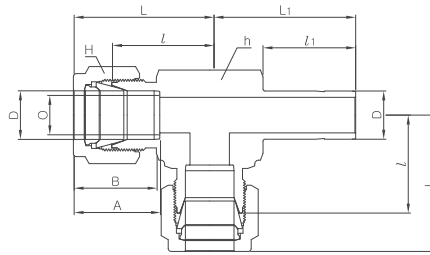
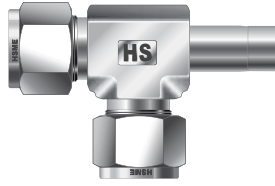

Connects fractional tube to fractional M Tube Fitting® port.

Part No.	Tube O.D. D		O Min.	Width across flat				A	B	I	I1	L	L1
	in	mm		h		H							
				in	mm	in	mm						
ATRA-4	1/4	6.35	4.8	1/2	12.70	9/16	14.28	15.24	17.78	19.55	15.75	27.0	25.00
ATRA-6	3/8	9.52	7.10	5/8	15.87	11/16	17.46	16.76	19.30	23.11	17.50	31.5	29.10
ATRA-8	1/2	12.70	10.41	13/16	20.63	7/8	22.22	22.86	21.84	25.90	23.10	36.0	37.3
ATRA-12	3/4	19.05	16.00	1-1/16	26.98	1-1/8	28.57	24.38	21.84	29.71	24.70	38.8	42.6
ATRA-16	1	25.40	22.30	1-3/8	34.92	1-1/2	38.10	31.24	26.41	46.83	31.70	42.6	54.40

Connects metric tube to metric M Tube fitting® port.

Part No.	Tube O.D. D	O Min.	Width across flat		A	B	I	I1	L	L1
			h	H						
ATRA-8M	8	6.4	15.8	16	16.2	18.6	21.3	16.8	28.8	27.5
ATRA-10M	10	7.9	17.4	19	17.2	19.5	23.9	17.5	31.5	30.0

## Branch Tee Tube Adapter **ATBA**

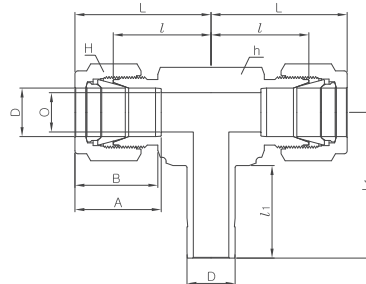

Connects fractional tube to fractional M Tube Fitting® port.

Part No.	Tube O.D. D		O Min.	Width across flat				A	B	I	I1	L	L1
	in	mm		h		H							
				in	mm	in	mm						
ATBA-4	1/4	6.35	4.8	1/2	12.70	9/16	14.28	15.24	17.78	19.55	15.75	27.0	25.00
ATBA-6	3/8	9.52	7.10	5/8	15.87	11/16	17.46	16.76	19.30	23.11	17.50	31.5	29.10
ATBA-8	1/2	12.70	10.41	13/16	20.63	7/8	22.22	22.86	21.84	25.90	23.10	36.0	37.3
ATBA-12	3/4	19.05	16.00	1-1/16	26.98	1-1/8	28.57	24.38	21.84	29.71	24.70	38.8	42.6
ATBA-16	1	25.40	22.30	1-3/8	34.92	1-1/2	38.10	31.24	26.41	46.83	31.70	42.6	54.40

Connects metric tube to metric M Tube fitting® port.

Part No.	Tube O.D. D	O Min.	Width across flat		A	B	I	I1	L	L1
			h	H						
ATBA-8M	8	6.4	15.8	16	16.2	18.6	21.3	16.8	28.8	27.5

• Male NPT Tube Adapter  
**AAM-N**

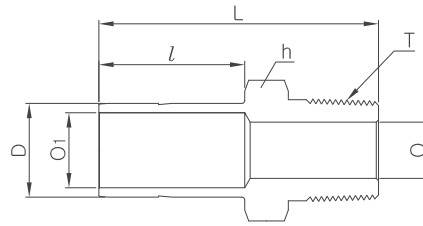
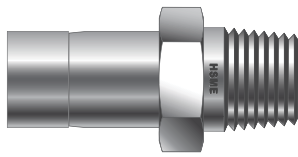

Connects fractional M Tube fitting® port to female NPT thread

Part No.	Tube O.D. D		T NPT	O Min.	O1	Width across flat h		/	L
	in	mm				in	mm		
AAM2-2N	1/8	3.17	1/8	4.57	1.77	7/16	11.11	13.45	29.50
AAM2-4N	1/8	3.17	1/4	7.11	1.77	9/16	14.28	13.45	34.80
AAM3-2N	3/16	4.76	1/8	4.57	3.04	7/16	11.11	14.20	30.22
AAM3-4N	3/16	4.76	1/4	7.11	3.04	9/16	14.28	14.20	35.56
AAM4-2N	1/4	6.35	1/8	4.57	4.57	7/16	11.11	15.75	31.80
AAM4-4N	1/4	6.35	1/4	7.11	4.57	9/16	14.28	15.75	37.08
AAM4-6N	1/4	6.35	3/8	10.41	4.57	11/16	17.46	15.75	37.84
AAM4-8N	1/4	6.35	1/2	12.70	4.57	7/8	22.22	15.75	43.43
AAM5-2N	5/16	7.93	1/8	4.57	6.35	7/16	11.11	16.80	32.76
AAM5-4N	5/16	7.93	1/4	7.11	6.35	9/16	14.28	16.80	38.10
AAM6-2N	3/8	9.52	1/8	4.57	7.11	7/16	11.11	17.50	33.50
AAM6-4N	3/8	9.52	1/4	7.11	7.11	9/16	14.28	17.50	38.90
AAM6-6N	3/8	9.52	3/8	10.41	7.11	11/16	17.46	17.50	39.60
AAM6-8N	3/8	9.52	1/2	12.70	7.11	7/8	22.22	17.50	45.20
AAM8-4N	1/2	12.70	1/4	7.11	9.90	9/16	14.28	23.20	44.50
AAM8-6N	1/2	12.70	3/8	10.41	9.90	11/16	17.46	23.20	45.20
AAM8-8N	1/2	12.70	1/2	12.70	9.90	7/8	22.22	23.20	50.50
AAM10-6N	5/8	15.87	3/8	10.41	12.70	11/16	17.46	24.70	47.40
AAM10-8N	5/8	15.87	1/2	12.70	12.70	7/8	22.22	24.70	52.30
AAM10-2N	5/8	15.87	3/4	18.28	12.70	1-1/16	26.98	24.70	52.30
AAM12-8N	3/4	19.05	1/2	12.70	14.98	7/8	22.22	24.70	52.30
AAM12-12N	3/4	19.05	3/4	18.28	14.98	1-1/16	26.98	24.70	52.30
AAM12-16N	3/4	19.05	1	22.35	14.98	1-3/8	34.92	24.70	57.91
AAM14-12N	7/8	22.22	3/4	18.28	17.27	1-1/16	26.98	26.70	54.30
AAM16-12N	1	25.40	3/4	18.28	20.06	1-1/16	26.98	31.70	58.70
AAM16-16N	1	25.40	1	22.35	20.06	1-3/8	34.92	31.70	66.00
AAM20-20N	1-1/4	31.75	1-1/4	27.68	-	1-3/4	44.45	40.00	80.26
AAM24-24N	1-1/2	38.10	1-1/2	33.27	-	2-1/8	53.98	51.50	94.48
AAM32-32N	2	50.80	2	44.45	-	2-3/4	69.85	68.40	119.38

Connects metric M Tube fitting® port to female NPT thread

Part No.	Tube O.D. D	T NPT	O Min.	O <sub>1</sub>	Width across flat h		/	L1
					in	mm		
AAM3M-2N	3	1/8	4.0	1.8	12	13.15	29.4	
AAM6M-2N	6	1/8	4.6	4.6	12	15.75	32.8	
AAM6M-4N	6	1/4	4.6	4.6	14	15.75	38.1	
AAM8M-4N	8	1/4	6.3	6.3	14	16.50	39.1	
AAM10M-4N	10	1/4	7.7	7.7	14	17.50	39.9	
AAM10M-6N	10	3/8	7.7	7.7	17	17.50	40.6	
AAM10M-8N	10	1/2	11.9	7.7	22	17.50	45.2	
AAM12M-4N	12	1/4	7.1	9.1	14	23.50	46.5	
AAM12M-6N	12	3/8	9.1	9.1	17	23.50	46.5	
AAM12M-8N	12	1/2	11.9	9.1	22	23.50	51.8	
AAM18M-8N	18	1/2	11.9	13.9	22	24.90	53.2	
AAM18M-12N	18	3/4	15.9	13.9	27	24.90	53.2	
AAM28M-16N	28	1	22.2	-	35	31.70	74.7	
AAM28M-20N	28	1-1/4	23.8	-	46	31.70	76.2	
AAM32M-20N	32	1-1/4	27.4	-	46	40.00	81.0	
AAM38M-24N	38	1-1/2	33.3	-	55	51.50	92.2	

**Male Adapter**

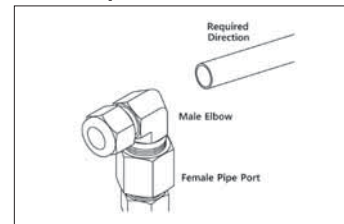

Male elbow is tightened in the wrong direction.

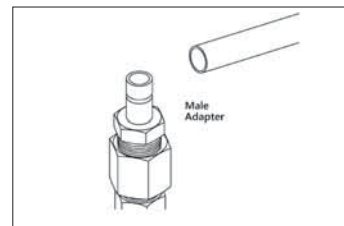

As a solution, Male adapter is tightened into female port.

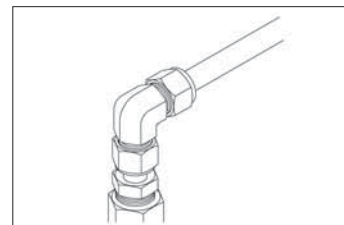

Connect union elbow to the male adapter, and set the direction. Follow M tube fitting's standard installation Instruction.

**Elbow Adapter – Another Solution**

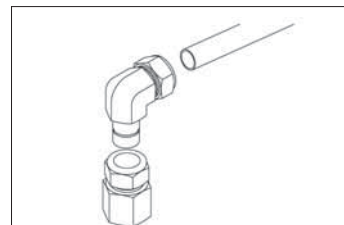

Elbow adapter on M Tube Fitting Port eliminates alignment problem.

# M Tube Fittings®

## Male BSPT Tube Adapter **AAM-R**

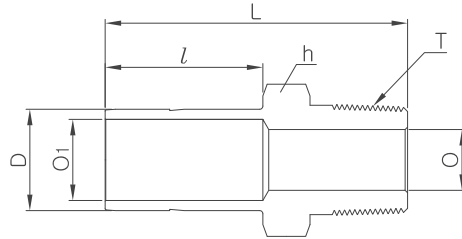
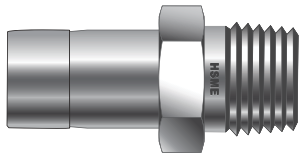

Connects fractional M Tube fitting® port to female ISO tapered thread

Part No.	Tube O.D. D		T PT	O Min.	O1	Width across flat h		/	L
	in	mm				in	mm		
AAM2-2N	1/8	3.17	1/8	4.57	1.77	7/16	11.11	13.45	29.50
AAM2-4N	1/8	3.17	1/4	7.11	1.77	9/16	14.28	13.45	34.80
AAM4-2N	1/4	6.35	1/8	4.57	4.57	7/16	11.11	15.75	31.80
AAM4-4N	1/4	6.35	1/4	7.11	4.57	9/16	14.28	15.75	37.08
AAM4-6N	1/4	6.35	3/8	10.41	4.57	11/16	17.46	15.75	37.84
AAM6-4N	3/8	9.52	1/4	7.11	7.11	9/16	14.28	17.50	38.90
AAM6-6N	3/8	9.52	3/8	10.41	7.11	11/16	17.46	17.50	39.60
AAM6-8N	3/8	9.52	1/2	12.70	7.11	7/8	22.22	17.50	45.20
AAM8-4N	1/2	12.70	1/4	7.11	9.90	9/16	14.28	23.20	44.50
AAM8-6N	1/2	12.70	3/8	10.41	9.90	11/16	17.46	23.20	45.20
AAM8-8N	1/2	12.70	1/2	12.70	9.90	7/8	22.22	23.20	50.50
AAM8-12N	1/2	12.70	3/4	15.74	9.90	1-1/16	26.98	23.10	50.70
AAM12-8N	3/4	19.05	1/2	12.70	14.98	7/8	22.22	24.70	52.30
AAM12-12N	3/4	19.05	3/4	14.98	14.98	1-1/16	26.98	24.70	52.30

Connects metric M Tube fitting® port to female ISO tapered thread

Part No.	Tube O.D. D	T NPT	O Min.	O1 Min.	Width across flat h	/	L
AAM3M-2R	3	1/8	4.0	1.8	12	13.15	29.4
AAM6M-2R	6	1/8	4.6	4.6	12	15.75	32.8
AAM6M-4R	6	1/4	4.6	4.6	14	15.75	38.1
AAM8M-4R	8	1/4	6.3	6.3	14	16.50	39.1
AAM10M-4R	10	1/4	7.7	7.7	14	17.50	39.9
AAM10M-6R	10	3/8	7.7	7.7	17	17.50	40.6
AAM10M-8R	10	1/2	11.9	7.7	22	17.50	45.2
AAM12M-4R	12	1/4	7.1	9.1	14	23.50	46.5
AAM12M-6R	12	3/8	9.1	9.1	17	23.50	46.5
AAM12M-8R	12	1/2	11.9	9.1	22	23.50	51.8
AAM18M-8R	18	1/2	11.9	13.9	22	24.90	53.2
AAM18M-12R	18	3/4	15.9	13.9	27	24.90	53.2
AAM25M-16R	25	1	19.8	19.8	35	31.70	66.0
AAM28M-16R	28	1	22.2	-	35	31.70	74.7
AAM28M-20R	28	1-1/4	23.8	-	46	31.70	76.2
AAM30M-20R	30	1-1/4	24.6	-	46	40.60	80.0
AAM32M-20R	32	1-1/4	27.4	-	46	40.00	81.0
AAM38M-24R	38	1-1/2	33.3	-	55	51.50	92.2

• Male ISO Parallel  
Tube Adapter  
**AAM-G**

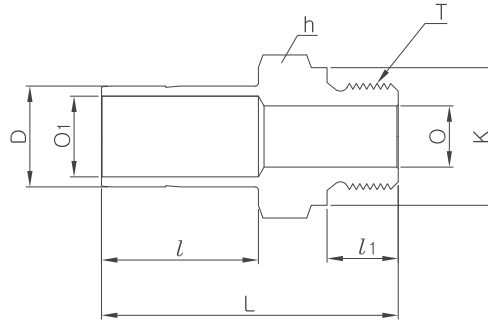
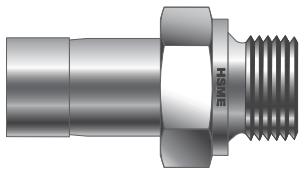

Connects fractional **M** Tube fitting® port to female ISO parallel thread

Part No.	Tube O.D. D		T PT	O Min.	O1	Width across flat h		l	l1	L	K
	in	mm				in	mm				
	AAM2-2G	1/8				3.17	1/8				
AAM2-4G	1/8	3.17	1/4	6.4	1.77	3/4	19.05	13.45	11.2	35.8	18.0
AAM4-2G	1/4	6.35	1/8	4.57	4.57	9/16	14.28	15.75	7.10	33.27	13.8
AAM4-4G	1/4	6.35	1/4	4.57	4.57	3/4	19.05	15.75	11.2	38.1	18.0
AAM6-4G	3/8	9.52	1/4	5.9	7.11	3/4	19.05	17.50	11.2	39.8	18.0
AAM6-6G	3/8	9.52	3/8	7.11	7.11	7/8	22.22	17.50	11.2	40.64	21.8
AAM8-4G	1/2	12.70	1/4	5.9	9.90	3/4	19.05	23.10	11.2	45.5	18.0
AAM8-6G	1/2	12.70	3/8	7.9	9.90	7/8	22.22	23.10	11.2	46.2	21.8
AAM8-8G	1/2	12.70	1/2	11.9	9.90	1-1/16	26.98	23.10	14.2	49.3	26.0
AAM12-12G	3/4	19.05	3/4	14.98	14.98	1-5/16	33.33	24.70	15.7	54.86	32.0
AAM16-16G	1	25.40	1	20.06	20.06	1-5/8	41.28	31.7	18.3	64.5	39.0

Connects metric **M** Tube fitting® port to female ISO tapered thread

Part No.	Tube O.D. D	T NPT	O Min.	O1 Min.	Width across flat h	l	l1	L	K
AAM6M-2G	6	1/8	4.6	4.6	14	15.7	7.1	34.3	13.8
AAM6M-4G	6	1/4	4.6	4.6	19	15.7	11.2	39.1	18.0
AAM8M-4G	8	1/4	5.9	5.9	19	16.8	11.2	40.1	18.0
AAM10M-4G	10	1/4	5.9	7.7	19	17.5	11.2	40.9	18.0
AAM10M-6G	10	3/8	7.7	7.7	22	17.5	11.2	41.7	21.8
AAM10M-8G	10	1/2	7.7	7.7	27	17.5	14.2	44.7	26.0
AAM12M-4G	12	1/4	5.9	9.1	19	23.1	11.2	46.7	18.0
AAM12M-6G	12	3/8	7.9	9.1	22	23.1	11.2	47.2	21.8
AAM12M-8G	12	1/2	9.1	9.1	27	23.1	14.2	50.5	26.0
AAM18M-8G	18	1/2	11.9	13.9	27	24.6	14.2	52.1	26.0
AAM18M-12G	18	3/4	15.9	13.9	35	24.6	15.7	56.1	32.0
AAM22M-12G	22	3/4	15.9	18.3	35	26.6	15.7	57.4	32.0
AAM25M-16G	25	1	19.8	19.8	41	31.7	18.3	67.1	39.0
AAM28M-16G	28	1	19.8	22.2	41	37.5	18.3	72.9	39.0
AAM28M-20G	28	1-1/4	23.8	23.8	50	37.5	19.8	77.0	49.0
AAM30M-20G	30	1-1/4	24.6	24.6	50	40.66	19.8	80.8	49.0
AAM32M-20G	32	1-1/4	25.0	25.0	50	40.0	19.8	81.8	49.0
AAM38M-24G	38	1-1/2	31.8	31.8	55	50.4	22.1	94.5	54.7

# M Tube Fittings®

## Male SAE Tube Adapter AAM-UF

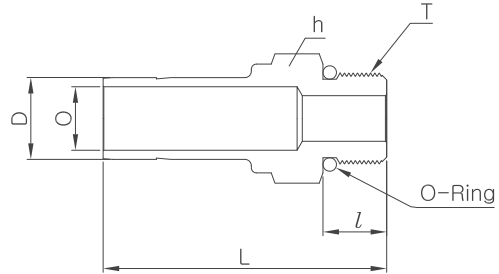
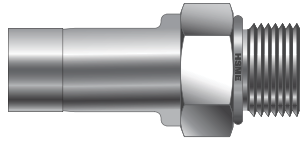

Connects fractional M Tube fitting® port to SAE straight thread boss

Part No.	Tube O.D. D		T U	O Min.	Width across flat h		/	L	O-Ring Uniform Size Number
	in	mm			in	mm			
AAM2-2UF	1/8	3.17	5/16-24	2.03	7/16	11.11	7.62	30.48	-902
AAM4-4UF	1/4	6.35	7/16-20	4.31	9/16	14.28	9.14	35.30	-904
AAM6-4UF	3/8	9.52	7/16-20	5.08	9/16	14.28	9.14	37.08	-904
AAM6-6UF	3/8	9.52	9/16-18	6.85	11/16	17.46	9.90	38.60	-906
AAM6-8UF	3/8	9.52	3/4-16	6.85	7/8	22.22	11.17	40.64	-908
AAM8-6UF	1/2	12.70	9/16-18	7.11	11/16	17.46	9.90	44.20	-906
AAM8-8UF	1/2	12.70	3/4-16	9.90	7/8	22.22	11.17	46.22	-908
AAM12-12UF	3/4	19.05	1-1/16-12	14.98	1-1/4	31.75	14.98	53.34	-912
AAM16-16UF	1	25.40	1-5/16-12	20.31	1-1/2	38.1	14.98	61.21	-916

## Male O-Seal Tube Adapter AAM-UO

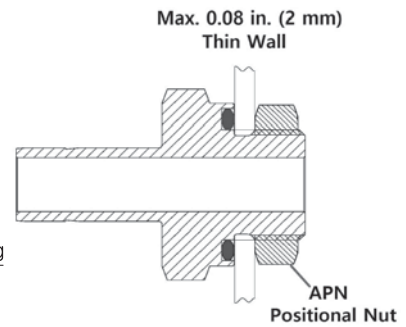
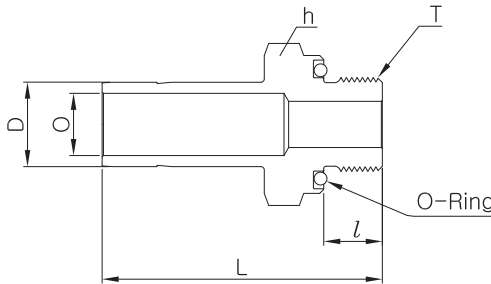
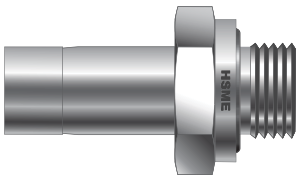

### Unique Application

On thin wall tanks or vessels, O-Seal fitting works as a leak-tight bulkhead fitting along with a positionable nut - APN without brazing or welding.

Connects fractional M Tube fitting® port to SAE straight thread boss

Part No.	Tube O.D. D		T U	O Min.	Width across flat h		/	L	O-Ring Uniform Size Number
	in	mm			in	mm			
AAM2-2UO	1/8	3.17	5/16-24	2.03	9/16	14.28	8.63	32.51	-011
AAM3-3UO	3/16	4.76	3/8-24	3.05	5/8	15.87	9.65	35.05	-012
AAM4-4UO	1/4	6.35	7/16-20	4.32	3/4	19.05	10.41	39.11	-013
AAM5-5UO	5/16	7.52	1/2-20	5.59	7/8	22.22	11.17	41.65	-112
AAM6-6UO	3/8	9.52	9/16-18	6.85	15/16	23.81	11.93	43.18	-113
AAM8-8UO	1/2	12.70	3/4-16	9.40	1-1/8	28.57	11.93	49.53	-116

• Male AN  
Tube Adapter  
**AMAA**

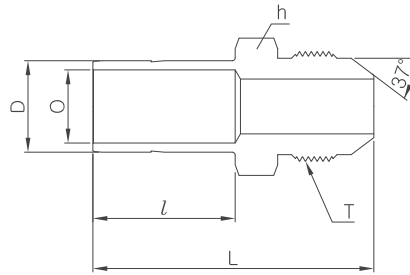
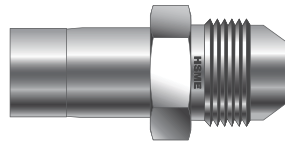

Connects fractional **M** Tube fitting® port to AN flare tube

Part No.	Tube O.D. D		AN Tube Flare Size		Straight Thread T(U)	O Min.	Width across flat h		l	L
	in	mm	in	mm			in	mm		
AMAA4-4	1/4	6.35	1/4	6.35	7/16-20	4.57	1/2	12.70	15.75	37.1
AMAA6-6	3/8	9.52	3/8	9.52	9/16-18	7.11	5/8	15.87	17.5	39.63
AMAA8-6	1/2	12.70	3/8	9.52	9/16-18	7.11	5/8	15.87	23.1	45.7
AMAA8-8	1/2	12.70	1/2	12.70	3/4-16	9.9	13/16	20.64	23.1	48.52
AMAA8-10	1/2	12.70	5/8	15.87	7/8-14	9.9	15/16	23.81	23.1	52.0
AMAA10-10	5/8	15.87	5/8	15.87	7/8-14	12.3	15/16	23.81	27.68	56.13
AMAA12-12	3/4	19.05	3/4	19.05	1-1/16-12	14.98	1-1/8	28.58	24.7	56.13
AMAA16-16	1	25.40	1	25.40	1-5/16-12	20.06	1-3/8	34.92	31.7	65.33

• Female NPT  
Tube Adapter  
**AAF-N**

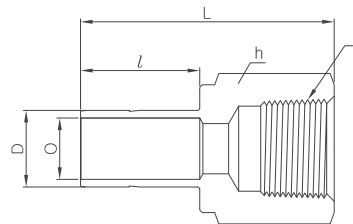
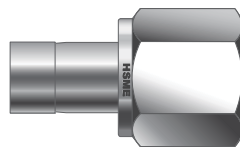

Connects fractional tube to fractional **M** Tube fitting® port

Part No.	Tube O.D. D		T (NPT)	O Min.	Width across flat h		l	L
	in	mm			in	mm		
AAF2-2N	1/8	3.17	1/8	1.77	9/16	14.28	13.45	31.50
AAF2-4N	1/8	3.17	1/4	1.77	3/4	19.05	13.45	35.30
AAF3-2N	3/16	4.76	1/8	3.04	9/16	14.28	14.20	32.00
AAF3-4N	3/16	4.76	1/4	3.04	3/4	19.05	14.20	35.81
AAF4-2N	1/4	6.35	1/8	4.57	9/16	14.28	15.75	33.02
AAF4-4N	1/4	6.35	1/4	4.57	3/4	19.05	15.75	37.10
AAF4-6N	1/4	6.35	3/8	4.57	7/8	22.22	15.75	39.37
AAF4-8N	1/4	6.35	1/2	4.57	1-1/16	26.98	15.75	45.50
AAF5-2N	5/16	7.93	1/8	6.35	9/16	14.28	16.80	34.29
AAF5-4N	5/16	7.93	1/4	6.35	3/4	19.05	16.80	37.59
AAF6-2N	3/8	9.52	1/8	7.11	9/16	14.28	17.50	34.29
AAF6-4N	3/8	9.52	1/4	7.11	3/4	19.05	17.50	38.10
AAF6-6N	3/8	9.52	3/8	7.11	7/8	22.22	17.50	40.38
AAF6-8N	3/8	9.52	1/2	7.11	1-1/16	26.98	17.50	46.73
AAF8-4N	1/2	12.70	1/4	9.90	3/4	19.05	23.20	43.43
AAF8-6N	1/2	12.70	3/8	9.90	7/8	22.22	23.20	45.46
AAF8-8N	1/2	12.70	1/2	9.90	1-1/16	26.98	23.20	51.80
AAF10-6N	5/8	15.87	3/8	12.70	7/8	22.22	24.70	48.26
AAF10-8N	5/8	15.87	1/2	12.70	1-1/16	26.98	24.70	53.84
AAF10-12N	5/8	15.87	3/4	12.70	1-5/16	33.33	24.70	55.37
AAF12-8N	3/4	19.05	1/2	14.98	1-1/16	26.98	24.70	52.83
AAF12-12N	3/4	19.05	3/4	14.98	1-5/16	33.33	24.70	54.86
AAF12-16N	3/4	19.05	1	14.98	1-5/8	41.27	24.70	58.42
AAF14-12N	7/8	22.22	3/4	17.27	1-5/16	33.33	26.70	57.15
AAF16-12N	1	25.40	3/4	20.06	1-5/16	33.33	31.70	60.70
AAF16-16N	1	25.40	1	20.06	1-5/8	41.27	31.70	64.26
AAF20-20N	1-1/4	31.75	1-1/4	27.68	2-1/8	53.98	40.00	77.72
AAF24-24N	1-1/2	38.10	1-1/2	33.27	2-3/8	60.33	51.50	88.90
AAF32-32N	2	50.80	2	44.45	2-7/8	73.03	68.40	107.44

# M Tube Fittings®

## Female NPT Tube Adapter AAF-N

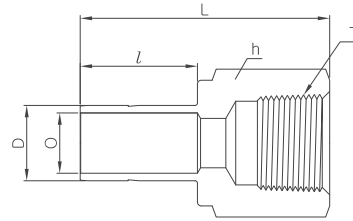
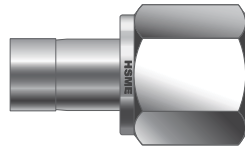

Connects metric M Tube fitting® port to male NPT thread

Part No.	Tube O.D. D	T NPT	O Min.	Width across flat h	/	L
AAF6M-2N	6	1/8	4.6	14	15.75	32.50
AAF6M-4N	6	1/4	4.6	19	15.75	37.10
AAF8M-4N	8	1/4	6.3	19	16.50	37.60
AAF10M-4N	10	1/4	7.7	19	17.50	38.10
AAF10M-6N	10	3/8	7.7	22	17.50	40.10
AAF10M-8N	10	1/2	7.7	27	17.50	46.50
AAF12M-4N	12	1/4	9.1	19	23.50	43.70
AAF12M-6N	12	3/8	9.1	22	23.50	46.00
AAF12M-8N	12	1/2	9.1	27	23.50	52.30

## Female BSPT Tube Adapter AAF-R

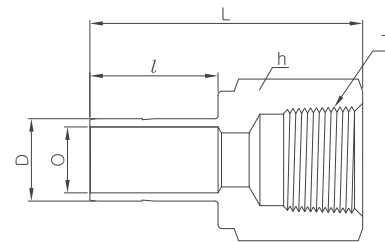
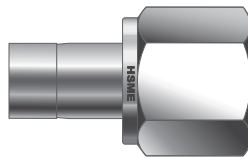

Connects fractional M Tube fitting® port to male ISO tapered thread

Part No.	Tube O.D. D		T PT	O Min.	Width across flat h		/	L
	in	mm			in	mm		
	AAF4-2R	1/4			6.35	1/8		
AAF4-4R	1/4	6.35	1/4	4.57	3/4	19.05	15.75	37.10
AAF6-4R	3/8	9.52	1/4	7.11	3/4	19.05	17.50	38.10
AAF6-6R	3/8	9.52	3/8	7.11	7/8	22.22	17.50	40.38
AAF8-4R	1/2	12.70	1/4	9.90	3/4	19.05	23.20	43.43
AAF8-6R	1/2	12.70	3/8	9.90	7/8	22.22	23.20	45.46
AAF8-8R	1/2	12.70	1/2	9.90	1-1/16	26.98	23.20	51.80
AAF10-8R	5/8	15.87	1/2	12.70	1-1/16	26.98	24.70	53.84
AAF12-8R	3/4	19.05	1/2	14.98	1-1/16	26.98	24.70	52.83
AAF12-12R	3/4	19.05	3/4	14.98	1-5/16	33.33	24.70	54.86
AAF16-16R	1	25.40	1	20.06	1-5/8	41.27	31.70	64.26

Connects metric M Tube fitting® port to male ISO tapered thread

Part No.	Tube O.D. D	T R(PT)	O Min.	Width across flat h	/	L
AAF6M-2R	6	1/8	4.6	14	15.75	32.50
AAF6M-4R	6	1/4	4.6	19	15.75	37.10
AAF8M-4R	8	1/4	6.3	19	16.50	37.60
AAF10M-4R	10	1/4	7.7	19	17.50	38.10
AAF10M-6R	10	3/8	7.7	22	17.50	40.10
AAF12M-4R	12	1/4	9.1	19	23.50	43.70
AAF12M-6R	12	3/8	9.1	22	23.50	46.00
AAF12M-8R	12	1/2	9.1	27	23.50	52.30



**Female Tube Adapter**

Adapters help reduce inventories

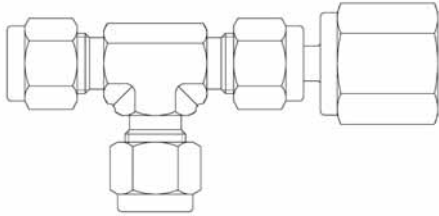

Female and Male Tube adapter convert Union Tee to Female Run Tee or Male Run Tee. Tube Adapters eliminate the need for stocking pipe thread tees.

Tube Adapter also converts Male or Female End to a tube adapter end.

Female ISO Parallel Tube Adapter  
**AAF-GZ**

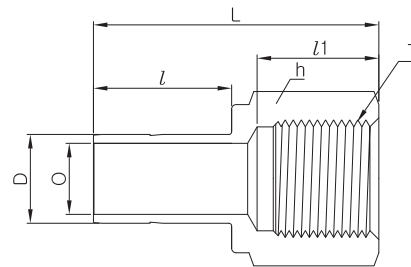
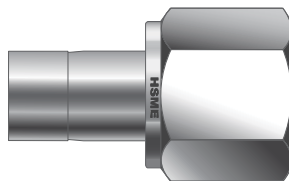

Connects fractional **M** Tube fitting® port to male ISO parallel thread

Part No.	Tube O.D. D		T PF	O Min.	Width across flat h		l	l1	L
	in	mm			in	mm			
	AAF4-2GZ	1/4			6.35	1/8			
AAF4-4GZ	1/4	6.35	1/4	4.57	3/4	19.05	15.75	18.5	38.10
AAF6-4GZ	3/8	9.52	1/4	7.11	3/4	19.05	17.50	18.5	39.40
AAF6-6GZ	3/8	9.52	3/8	7.11	7/8	22.22	17.50	18.5	39.90
AAF8-8GZ	1/2	12.70	1/2	9.90	1-1/16	26.98	23.20	22.1	49.50

Female Gauge Tube Adapter  
**AAF-GG**

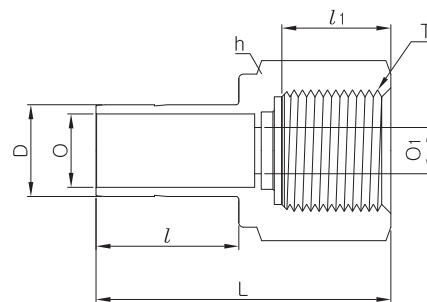
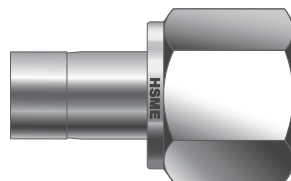

Connects fractional **M** Tube fitting® port to Gauge (Male ISO parallel thread)

Part No.	Tube O.D. D		T G(PF)	O Min.	O1	Width across flat h		l	l1	L
	in	mm				in	mm			
	AAF4-2GG	1/4				6.35	1/8			
AAF4-4GG	1/4	6.35	1/4	4.57	5.5	3/4	19.05	15.75	12.9	35.30
AAF6-6GG	3/8	9.52	3/8	7.11	6.5	7/8	22.22	17.50	14.1	39.37
AAF8-8GG	1/2	12.70	1/2	9.90	7.0	1-1/16	26.98	23.20	18.9	45.72

# M Tube Fittings®

## Female Gauge Tube Adapter AAF-GG

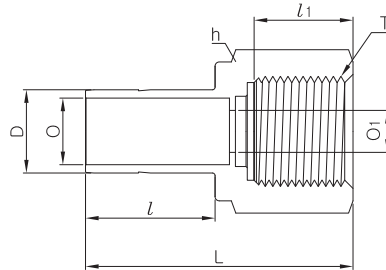
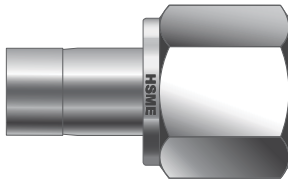

Gauge Adapter helps set a gauge-facing direction.

Connects metric M Tube fitting® port to Gauge (Male ISO parallel thread)

Part No.	Tube O.D. D	T G(PF)	O Min.	O1	Width across flat h	l	l1	L
AAF6M-2GG	6M	1/8	4.0	4.0	14	15.7	12.0	32.0
AAF6M-4GG	6M	1/4	4.0	5.5	19	15.7	13.0	35.3
AAF6M-6GG	6M	3/8	4.0	6.5	24	15.7	14.22	38.4
AAF6M-8GG	6M	1/2	4.0	7.0	27	15.7	18.9	42.9
AAF8M-4GG	8M	1/4	5.6	5.5	19	16.8	13.0	33.0
AAF8M-6GG	8M	3/8	5.6	6.5	24	16.8	14.22	39.3
AAF8M-8GG	8M	1/2	5.6	7.0	27	16.8	18.9	43.7
AAF10M-4GG	10M	1/4	7.7	5.5	19	17.5	13.0	34.5
AAF10M-6GG	10M	3/8	7.7	6.5	24	17.5	14.22	39.3
AAF10M-8GG	10M	1/2	7.7	7.0	27	17.5	18.9	40.1
AAF12M-4GG	12M	1/4	9.1	5.5	19	23.1	13.0	40.1
AAF12M-6GG	12M	3/8	9.1	6.5	24	23.1	14.22	44.9
AAF12M-8GG	12M	1/2	9.1	7.0	27	23.1	18.9	48.8
AAF15M-8GG	15M	1/2	12.0	7.0	27	24.65	18.9	49.0
AAF16M-8GG	16M	1/2	12.0	7.0	27	24.6	18.9	49.0
AAF18M-8GG	18M	1/2	13.9	7.0	27	24.9	18.9	49.3
AAF22M-8GG	22M	1/2	18.3	7.0	27	26.6	18.9	52.0
AAF25M-8GG	25M	1/2	19.8	7.0	30	31.7	18.9	56.1

## AN Adapter AAA

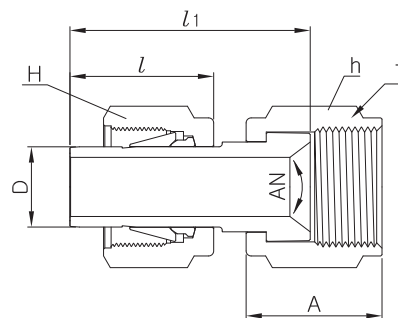
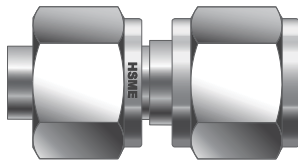

Connects fractional M Tube fitting® port to AN male

Part No.	Tube O.D. D		AN Tube Flare Size		Straight Thread T(U)	Width across flat				A	l	l1
	in	mm	in	mm		h		H				
AAA2-2	1/8	3.17	1/8	3.17	5/16-24	3/8	9.52	7/16	11.11	13.71	13.46	18.54
AAA2-4	1/8	3.17	1/4	6.35	7/16-20	9/16	14.28	7/16	11.11	15.74	13.46	19.05
AAA4-4	1/4	6.35	1/4	6.35	7/16-20	9/16	14.28	9/16	14.28	15.74	15.74	21.33
AAA6-6	3/8	9.52	3/8	9.52	9/16-18	11/16	17.46	11/16	17.46	18.28	17.52	24.89
AAA8-8	1/2	12.70	1/2	12.70	3/4-16	7/8	22.22	7/8	22.22	21.59	23.11	31.75

• Tube Socket  
Weld Connector  
**ACSW**

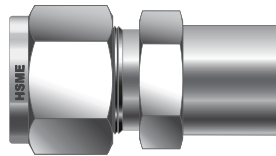

Tube Socket Weld Port  
designed to ASME B16.11.

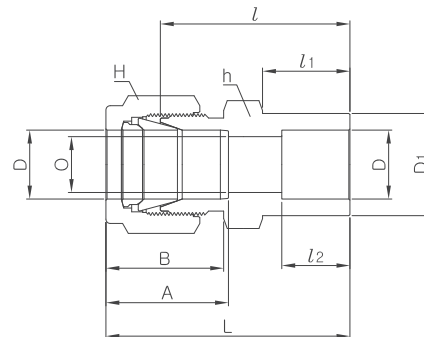

Connects fractional tubes

Part No.	Tube O.D. D		O Min.	D1	Width across flat				A	B	l	l1	l2	L
	in	mm			h		H							
					in	mm	in	mm						
ACSW2-2	1/8	3.17	2.28	7.87	7/16	11.11	7/16	11.11	12.70	15.24	22.35	8.63	6.35	28.95
ACSW4-4	1/4	6.35	4.82	11.17	1/2	12.70	9/16	14.28	15.24	17.78	26.16	10.41	7.87	33.52
ACSW6-6	3/8	9.52	7.11	15.74	5/8	15.87	11/16	17.46	16.76	19.30	30.22	11.93	9.65	37.59
ACSW8-8	1/2	12.70	10.41	19.05	13/16	20.64	7/8	22.22	22.86	21.84	30.98	11.93	12.70	41.14
ACSW12-12	3/4	19.05	15.74	26.67	1-1/16	26.98	1-1/8	28.58	24.38	21.84	33.27	11.93	14.22	43.43
ACSW16-16	1	25.40	22.35	33.27	1-3/8	34.92	1-1/2	38.10	31.24	26.41	40.38	14.22	19.05	52.57

• Tube Socket Weld Elbow  
**ALSW**

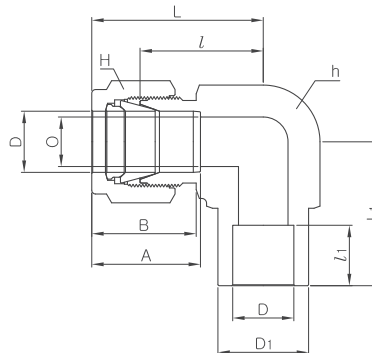
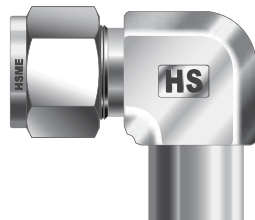

Connects fractional tubes

Part No.	Tube O.D. D		O Min.	D1	Width across flat				A	B	l	l1	L	L1
	in	mm			h		H							
					in	mm	in	mm						
ALSW4-4	1/4	6.35	4.82	12.70	1/2	12.70	9/16	14.28	15.24	17.78	19.55	7.87	26.92	19.55
ALSW6-6	3/8	9.52	7.11	15.74	5/8	15.87	11/16	17.46	16.76	19.30	23.11	9.65	30.48	23.11
ALSW8-8	1/2	12.70	10.41	20.57	13/16	20.64	7/8	22.22	22.86	21.84	25.90	12.70	36.06	25.90
ALSW12-12	3/4	19.05	15.74	26.92	1-1/16	26.98	1-1/8	28.58	24.38	21.84	29.71	14.22	39.87	29.71
ALSW16-16	1	25.40	22.35	35.05	1-3/8	34.93	1-1/2	38.10	31.24	26.41	36.83	19.05	49.02	36.83

• Pipe Butt Weld Connector  
**ACBW**

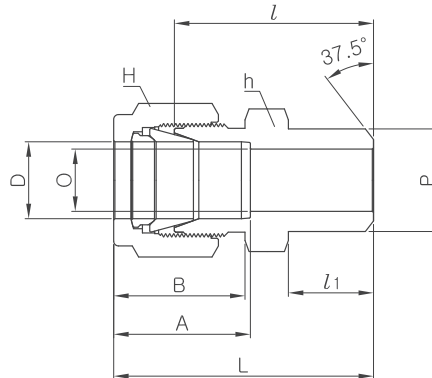
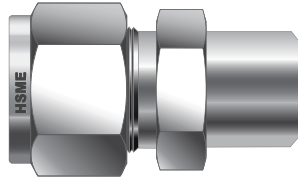

Connects fractional tube to pipe

Part No.	Tube O.D. D		Male Pipe Size P		O Min.	Width across flat				A	B	I	I1	L
	in	mm	Nom	O.D.		h		H						
						in	mm	in	mm					
ACBW2-2P	1/8	3.17	1/8	10.29	2.28	7/16	11.11	7/16	11.11	12.70	15.24	23.87	9.65	31.24
ACBW3-2P	3/16	4.76	1/8	10.29	3.04	7/16	11.11	1/2	12.70	13.71	16.00	24.63	9.65	31.24
ACBW4-2P	1/4	6.35	1/8	10.29	4.82	1/2	12.70	9/16	14.28	15.24	17.78	25.40	9.65	32.76
ACBW4-4P	1/4	6.35	1/4	13.72	4.82	9/16	14.28	9/16	14.28	15.24	17.78	30.48	14.22	37.84
ACBW5-2P	5/16	7.93	1/8	10.29	5.08	9/16	14.28	5/8	15.87	16.25	18.54	26.67	9.65	34.03
ACBW5-4P	5/16	7.93	1/4	13.72	6.35	9/16	14.28	5/8	15.87	16.25	18.54	31.24	14.22	38.60
ACBW6-4P	3/8	9.52	1/4	13.72	7.11	5/8	15.87	11/16	17.46	16.76	19.30	32.51	14.22	39.87
ACBW6-6P	3/8	9.52	3/8	17.15	7.11	11/16	17.46	11/16	17.46	16.76	19.30	32.51	14.22	39.87
ACBW6-8P	3/8	9.52	1/2	21.34	7.11	7/8	22.22	11/16	17.46	16.76	19.30	38.86	11.05	43.23
ACBW8-6P	1/2	12.70	3/8	17.15	10.41	13/16	20.64	7/8	22.22	22.86	21.84	33.27	14.22	43.43
ACBW8-8P	1/2	12.70	1/2	21.34	10.41	7/8	22.22	7/8	22.22	22.86	21.84	38.86	19.05	49.02
ACBW8-12P	1/2	12.70	3/4	26.67	10.41	1-1/16	26.98	7/8	22.22	22.86	21.84	40.38	19.05	50.54
ACBW10-8P	5/8	15.87	1/2	21.34	12.70	15/16	23.81	1	25.40	24.38	21.84	38.86	19.05	49.02
ACBW12-12P	3/4	19.05	3/4	26.67	15.74	1-1/16	26.98	1-1/8	28.58	24.38	21.84	40.38	19.05	50.54
ACBW16-16P	1	25.40	1	33.40	22.35	1-3/8	34.92	1-1/2	38.10	31.24	26.41	50.03	23.87	62.23
ACBW20-20P	1-1/4	31.75	1-1/4	42.16	27.68	1-3/4	44.45	2	50.80	41.14	38.86	55.11	23.87	77.21
ACBW24-24P	1-1/2	38.10	1-1/2	48.26	34.03	2-1/8	53.98	2-1/4	57.15	50.03	45.21	61.72	26.16	88.90
ACBW32-32P	2	50.80	2	60.33	47.75	2-3/4	69.85	3	76.20	67.56	62.73	76.20	26.92	113.53

Connects metric tube to pipe

Part No.	Tube O.D. D	Male Pipe Size P		O Min.	Width across flat		A	B	I	I1	L
		Nom	O.D.		h	H					
ACBW3M-2P	3	1/8	10.29	2.4	12	12	12.9	15.3	23.1	9.7	29.7
ACBW4M-2P	4	1/8	10.29	2.4	12	12	13.7	16.1	24.1	9.7	30.7
ACBW6M-2P	6	1/8	10.29	4.8	14	14	15.3	17.7	25.4	9.7	32.8
ACBW6M-4P	6	1/4	13.72	4.8	14	14	15.3	17.7	30.2	14.2	37.6
ACBW8M-2P	8	1/8	10.29	5.1	15	16	16.2	18.6	26.7	9.7	34.2
ACBW8M-4P	8	1/4	13.72	6.4	15	16	16.2	18.6	31.2	14.2	38.7
ACBW8M-8P	8	1/2	21.34	6.4	22	16	16.2	18.6	37.3	19.0	44.8
ACBW10M-4P	10	1/4	13.72	7.1	18	19	17.2	19.5	33.3	14.2	40.9
ACBW10M-6P	10	3/8	17.15	7.9	18	19	17.2	19.5	32.5	14.2	40.1
ACBW10M-8P	10	1/2	21.34	7.9	22	19	17.2	19.5	38.1	19.0	45.7
ACBW12M-4P	12	1/4	13.72	7.1	22	22	22.8	22.0	33.3	14.2	43.4
ACBW12M-6P	12	3/8	17.15	9.5	22	22	22.8	22.0	33.3	14.2	43.4
ACBW12M-8P	12	1/2	21.34	9.5	22	22	22.8	22.0	38.1	19.0	48.2
ACBW14M-6P	14	3/8	17.15	10.3	24	25	24.4	22.0	34.0	14.2	44.1
ACBW15M-8P	15	1/2	21.34	11.9	24	25	24.4	22.0	38.9	19.0	49.0
ACBW16M-8P	16	1/2	21.34	12.7	24	25	24.4	22.0	38.9	19.0	49.0
ACBW18M-8P	18	1/2	21.34	13.5	27	30	24.4	22.0	40.4	19.0	50.5
ACBW32M-20P	32	1-1/4	42.16	28.6	46	50	42.0	41.6	56.6	23.9	79.6
ACBW38M-24P	38	1-1/2	48.26	33.7	55	60	49.4	47.9	64.0	26.2	91.6

**Welding Information**

M Tube Fitting butt weld ends are constructed to SCH 80 or greater.

Prior to weld, remove nut and ferrules from M Tube Fitting.

- This protects the nut and ferrules from weld heat.

Cover the M Tube Fitting Port with a protective device such as port plug.

- This protects threads and sealing surface of fitting port from weld splatter.
- Finger-tighten the port plug so that it can be used many times.

After welding, replace the port plug with the nut and ferrules.

• Pipe Butt Weld Elbow  
**ALBW**

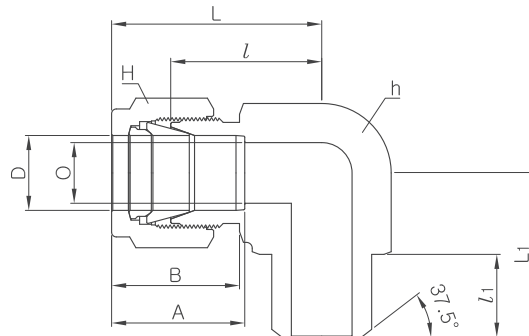
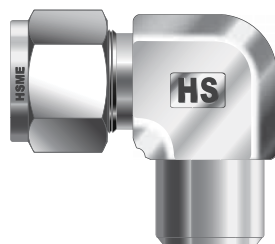

Connects fractional tube to pipe

Part No.	Tube O.D. D		Male Pipe Size P		O Min.	Width across flat				A	B	/	/1	L	L1
	in	mm	Nom	O.D		h		H							
						in	mm	in	mm						
ALBW 2-2P	1/8	3.17	1/8	10.29	4.82	1/2	12.70	9/16	14.28	15.24	17.78	19.55	9.65	26.92	18.79
ALBW 4-4P	1/4	6.35	1/4	13.72	4.82	1/2	12.70	9/16	14.28	15.24	17.78	19.55	14.22	26.92	23.36
ALBW 6-4P	3/8	9.52	1/4	13.72	7.11	5/8	15.87	11/16	17.46	16.76	19.30	23.11	14.22	30.48	25.40
ALBW 8-8P	1/2	12.70	1/2	21.34	10.41	13/16	20.64	7/8	22.22	22.86	21.84	25.90	19.05	36.06	33.02
ALBW 12-12P	3/4	19.05	3/4	26.67	15.74	1-1/16	26.98	1-1/8	28.58	24.38	21.84	29.71	19.05	39.87	36.83

• Bulkhead Weld Union  
**ABUW**

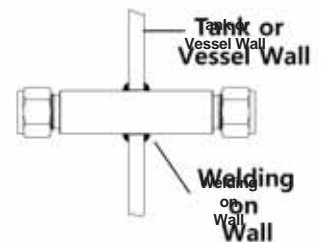
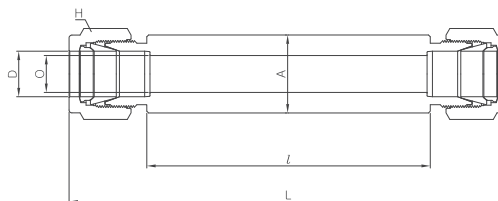

Connects fractional tubes

Part No.	Tube O.D. D		O Min.	A Diameter	Width across flat		/	L
	in	mm			H			
					in	mm		
ABUW-4	1/4	6.35	4.8	16.0	9/16	14.28	80.0	115.4
ABUW-6	3/8	9.52	7.1	19.0	11/16	17.46	80.0	118.4
ABUW-8	1/2	12.70	10.41	22.0	7/8	22.22	80.0	124.0

## Flange Adapters

### AF

Flanged Piping and Instrumentation M Tube Fitting are integrated in a compact one-piece flange adapter. The design eliminates welding or threading.

- Flange design meets ASME, DIN, and JIS standards
- Stainless Steel 316 material standard, alloy 600 and C276 for option.

M Tube Fitting	Flange		
	Standard	Nominal flange sizes	Pressure class rating
1/8 to 2 in. OD 3 to 50 mm OD	ANSI/ASME B16.5	NPS 1/2 to 2 in.	Class 150 to 2500
	EN 1092-1	DN 15 to 50	PN 40 to 100
	JIS B2220	DN 15 to 50	PN 10K to 63K

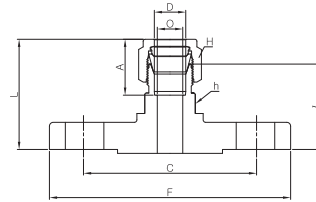

### ANSI Flange Adapters

Part No. Raised Face Flange	Tube O.D. in	Flange NPS	ANSI Class	O	Wrench Flat h	A	I	L	C	F	H
AF-4TF8-150	1/4	1/2	150	4.82	20.63	15.24	33.52	40.89	60.45	88.9	9/16
AF-6TF8-150	3/8	1/2	150	4.82	20.63	16.76	34.85	42.21	60.45	88.9	11/16
AF-6TF8-300		1/2	300	7.11	20.63	16.76	38.1	45.46	66.54	95.25	
AF-6TF16-150	1/2	1	150	7.11	20.63	16.76	37.85	45.21	79.2	108	7/8
AF-8TF8-150		1/2	150	10.41	20.63	22.86	35.05	45.21	60.45	88.9	
AF-8TF8-300		1/2	300	10.41	20.63	22.86	37.85	48.01	66.54	95.25	
AF-8TF8-1500		1/2	1500	10.41	20.63	22.86	46.05	56.21	82.6	121	
AF-8TF16-150	3/4	1	150	10.41	20.63	22.86	38.01	48.26	79.24	107.95	1 1/8
AF-8TF32-150		2	150	10.41	20.63	22.86	42.92	53.08	120.65	152.4	
AF-12TF16-150	1	1	150	15.74	31.75	24.38	40.13	50.29	79.24	107.95	1 1/2
AF-12TF16-900		1	900	15.74	31.75	24.38	46.05	56.21	89.0	124.0	
AF-16TF16-150	1 1/2	2	150	22.35	34.92	31.24	48.26	60.45	79.24	107.95	2 1/4
AF-24TF32-150	2	2	150	34.03	53.97	50.03	59.18	86.36	120.65	152.4	3
AF-32TF32-150		2	150	45.97	69.85	67.56	67.05	104.39	120.65	152.4	

### Pressure-Temperature Ratings

Stainless Steel ANSI Flange Ratings as per ASME B16.5 Group 2.2 Material. The ultimate pressure rating of flange adapters is determined by the lower pressure rating end either flange end or M Tube Fitting end.

#### Working Pressure by classes, psig

Temp. °F	ASME Class						
	150	300	400	600	900	1500	2500
-20 to 100	275	720	960	1440	2160	3600	6000
200	235	620	825	1240	1860	3095	5160
300	215	560	745	1120	1680	2795	4660
400	195	515	685	1025	1540	2570	4280
500	170	480	635	955	1435	2390	3980
600	140	450	600	900	1355	2255	3760
650	125	440	590	885	1325	2210	3680
700	110	435	580	870	1305	2170	3620
750	95	425	570	855	1280	2135	3560
800	80	420	565	845	1265	2110	3520
850	65	420	555	835	1255	2090	3480
900	50	415	555	830	1245	2075	3460
950	35	385	515	775	1160	1930	3220
1000	20	365	485	725	1090	1820	3030
1100	-	305	405	610	915	1525	2545

#### Working Pressure by classes, bar

Temp. °C	ASME Class						
	150	300	400	600	900	1500	2500
-29 to 38	19.0	49.6	66.2	99.3	148.9	248.2	413.7
50	18.4	48.1	64.2	96.2	144.3	240.6	400.9
100	16.2	42.2	56.3	84.4	126.6	211.0	351.6
150	14.8	38.5	51.3	77.0	115.5	192.5	320.8
200	13.7	35.7	47.6	71.3	107.0	178.3	297.2
250	12.1	33.4	44.5	66.8	100.1	166.9	278.1
300	10.2	31.6	42.2	63.2	94.9	158.1	263.5
325	9.3	30.9	41.2	61.8	92.7	154.4	257.4
350	8.4	30.3	40.4	60.7	91.0	151.6	252.7
375	7.4	29.9	39.8	59.8	89.6	149.4	249.0
400	6.5	29.4	39.3	58.9	88.3	147.2	245.3
425	5.5	29.1	38.9	58.3	87.4	145.7	242.9
450	4.6	28.8	38.5	57.7	86.5	144.2	240.4
475	3.7	28.7	38.2	57.3	86.0	143.4	238.9
500	2.8	28.2	37.6	56.5	84.7	140.9	235.0
538	1.4	25.2	33.4	50.0	75.2	125.5	208.9
600	-	20.3	27.0	40.5	60.8	101.3	168.9

**DIN Flange Adapters, Pressure Class PN 40**

Part No. Raised Face Flange	Tube O.D. D	DIN Flange Size, DN	O	Wrench Flat h	A	/	L	C	F	H
AF-6MF25-40-C	6 mm	25	4.8	20	15.3	40.1	47.5	85.0	115.0	14
AF-12MF15-40-C	12 mm	15	9.5	20	22.8	38.4	48.5	65.0	95.0	22
AF-12MF25-40-C		25	9.5	20	22.8	40.4	50.5	85.0	115.0	
AF-12MF50-40-C		50	9.5	20	22.8	45.2	55.3	125.0	165.0	
AF-18MF15-40-C	18 mm	15	15.1	32	24.4	41.7	51.8	65.0	95.0	30
AF-18MF25-40-C		25	15.1	32	24.4	43.7	53.8	85.0	115.0	
AF-25MF25-40-C	25 mm	25	21.8	35	31.3	51.8	64.0	85.0	115.0	38
AF-38MF50-40-C	38 mm	50	33.7	55	49.4	62.7	90.4	125.0	165.0	60
AF-50MF50-40-C	50 mm	50	45.2	70	65.0	66.3	103.0	125.0	165.0	76

**JIS Flange Adapters, Pressure Class 10K**

Part No. Raised Face Flange	Tube O.D. D	JIS Flange Size, DN	O	Wrench Flat h	A	/	L	C	F	H
AF-4TF15-10RF	1/4	15	4.82	20.63	15.24	34.79	42.16	70.1	94.99	9/16
AF-6TF15-10RF	3/8	15	7.11	20.63	16.76	36.32	43.68	70.1	94.99	11/16
AF-8TF15-10RF	1/2	15	10.41	20.63	22.86	36.32	46.48	70.1	94.99	7/8
AF-12TF15-10RF	3/4	15	15.74	31.75	24.38	38.35	48.51	70.1	94.99	1 1/8
AF-16TF25-10RF	1	25	22.35	34.92	31.24	48.76	60.96	89.91	124.96	1 1/2
AF-32TF50-10RF	2	50	45.97	69.85	67.56	64.51	101.85	119.88	154.94	3
AF-12MF15-10RF	12 mm	15	9.5	20	22.8	36.3	46.5	70	95	22 mm
AF-18MF15-10RF	18 mm	15	15.1	32	24.4	38.4	48.5	70	95	30 mm
AF-25MF25-10RF	25 mm	25	21.8	35	31.3	48.8	61	90	125	38 mm

• Lab Joint  
Flange Connector  
**AFC**

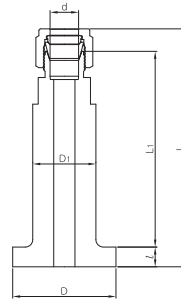

Part No.	Tube O.D. D in	Dimensions, mm				
		L	L1	/	D	D1
Serrated Finish						
AFC-4T8F-SR-SSA	1/4	80.8	56.5	6.5	35	22.2
AFC-6T8F-SR-SSA	3/8	82.3	56.5	6.5	35	22.2
AFC-8T8F-SR-SSA	1/2	84.8	56.5	6.5	35	22.2
Smooth Finish						
AFC-4T8F-SM-SSA	1/4	80.8	56.5	6.5	35	22.2
AFC-6T8F-SM-SSA	3/8	82.3	56.5	6.5	35	22.2
AFC-8T8F-SM-SSA	1/2	84.8	56.5	6.5 </td <td>35</td> <td>22.2</td>	35	22.2

Compact one-piece lab joint flange connector designed for a direct hook-up to the instrument tubing from the process line. Flange end is designed for use with 1/2 in. lap joint flange.

**Gasket Face of Flange**

Designators	
SR	SM
<p>External Groove</p>	
Finish, um	
Ra 6.3 to 12.5	Ra 3.2 to 6.3
Concentric serrated finish identifiable with an external groove.	Smooth finish leaves no definite tool marks apparent to naked eye.

## Dielectric Fittings AEU

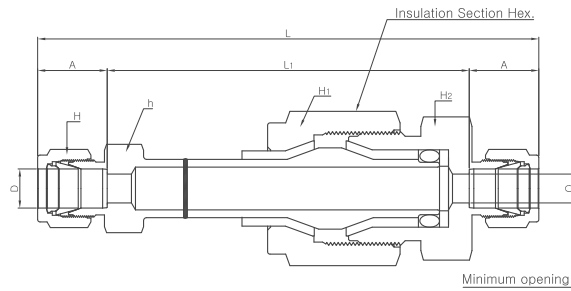
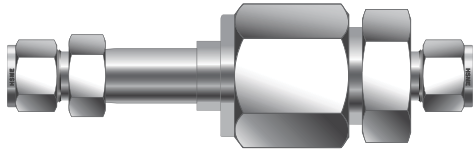

Part No.	Tube O.D. D	Pipe Thread T(NPT)	Dimensions, in. (mm)							
			O Min.	A	L	L1	h	H	H1	H2
AEU-4	1/4	-	0.19 (4.8)	15.24 mm	95.8 mm	65.3 mm	1/2 (12.7)	9/16 (14.28)	7/8 (22.22)	-
AEU-6	3/8	-	0.28 (7.1)	16.76 mm	99.6 mm	65.8 mm	5/8 (15.87)	11/16 (17.46)		13/16 (20.64)
AEU-8	1/2	-		22.86 mm	106 mm	60.2 mm	13/16 (20.64)	7/8 (22.22)		-
AEU-12M	12 mm	-		22.8 mm	107 mm	61.7 mm	22 mm	22 mm		22 mm
AEU6-4N	3/8	1/4	16.76 mm	94.7 mm	-	5/8 (15.87)	11/16	7/8 (22.22)		



### Features

1. Interruption on electrical current while permitting fluid flow.
2. Fitting interrupts cathodical current flow.
3. Electrical resistance:
  - $10^8$  ohms at 70°F (21 °C) and 50% relative humidity.
  - $10^6$  ohms at 100°F (37 °C) and 90% relative humidity.

M tube fitting Dielectric fittings are designed to interrupt the electrical current flowing through a pipe or tubing in order to protect vital instruments and metering equipment while permitting fluid flow.

**Warning:** The warning label below is placed over the insulation section hex.on every dielectric fitting.  
**Do not disconnect at this point!**



**CAUTION**  
DO NOT WRENCH THIS HEX  
NOR DISASSEMBLE THIS CONNECTION

### Materials of Construction

- Fitting material: Stainless Steel 316
- Insulator: Molded Thermoplastic
- O-ring: 90 Durometer FKM
- O-ring back up washer: Virgin PTFE

### Technical Data

Pressure Rating: 4,000 psig (275 bar) @ 70°F(21°C)  
Temperature Rating: -40 to -200°F (-40 to 93°C)

### Typical Application

Widely used in the natural gas transmission industry, the dielectric fitting prevents current flow, static electricity or even lightning strikes from reaching the monitoring station equipment.

If the current flow is not interrupted before reaching the monitoring station, sensitive equipment could be damaged or rendered inaccurate.

By using M Tube Dielectric Fitting on impulse lines between the pipeline and the monitoring station, current flow is interrupted while full fluid flow is permitted.

M Tube Two Ferrule system provides outstanding sealing in the impulse line.

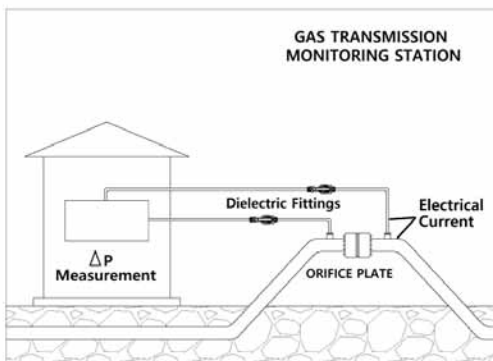



Fusible Plug  
**AFU**

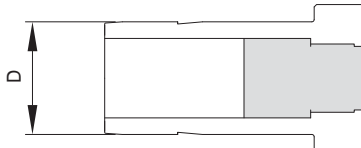
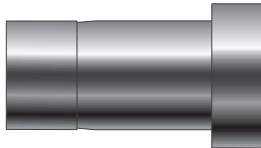

Connects to M Tube fitting® Port 3/8 in. OD

Part No.	Plug OD D in.	Melting Temperature Designator
AFU6-160-SS	3/8	160
AFU6-201-SS		201
AFU6-255-SS		255
AFU6-281-SS		281

**Technical Information**

Designator	Nominal Melting Temperature °F	Melting Temperature Ranges °F (°C)	Maximum Charging Pressure psig (bar)
160	160	160 (71) +/- 3%	150 (10.3)
201	201	201 (94) +/- 3%	
255	255	255 (124) +/- 3%	
281	281	281 (138) +/- 3%	

M Tube Fitting Fusible Plug is thermally actuated relief device that melts against the rated temperature not against pressure.

These safety devices are typically used over offshore platform where diesel engine runs to generate electrical power and the temperature inside of the engine chamber needs to be controlled. Usually instrument air is charged in the fusible plug that hits an alarm physically once the plug melts or yields against the chamber temperature.

This fire protection pressure relief plug is non-reclosing device.

Therefore the plug needs to be periodically examined for replacement if symptoms on corrosion are obvious on melting alloy.

Materials of Construction: Stainless steel Tube Adapter 3/8 in. OD and alloy metal inside.

For installation, follow the standard M Tube Fitting installation instruction.

Vent Protector  
**AVP**

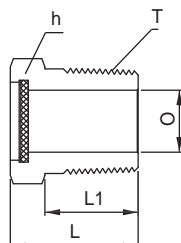
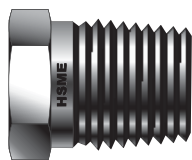

Connects to female NPT Port

Part No.	T NPT	O Min	h		L	L1
			in	mm		
AVP-4N	1/4	7.11	9/16	15.87	20.57	14.22
AVP-6N	3/8	10.40	11/16	17.46	20.57	14.22
AVP-8N	1/2	12.70	7/8	23.81	26.92	19.05
AVP-12N	3/4	16.00	1-1/16	26.98	28.70	19.05

M Tube Fitting Vent Protectors known as a bug protector protect open ends of outlet vents, instruments, and tubing.

The mesh wire screen prevents foreign bodies like insects or debris from entering and clogging open ends of systems.

Construction with bored-through pipe plug and stainless steel 40 x 40 mesh, 0.010 in. diameter wire screen.

• Tube Cap  
**AC**

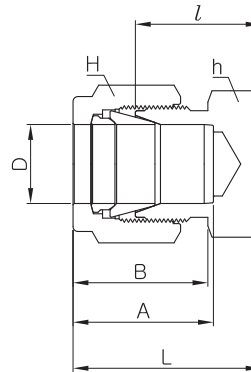
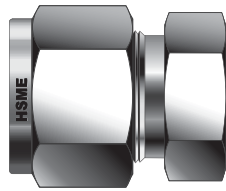

Cap Fractional tube end

Part No.	Tube O.D.		Width across flat				A	B	/	L
	D		h		H					
	in	mm	in	mm	in	mm				
AC-1	1/16	1.59	5/16	7.93	5/16	7.93	8.63	10.92	11.20	14.18
AC-2	1/8	3.17	7/16	11.11	7/16	11.11	12.70	15.14	13.46	20.06
AC-3	3/16	4.76	7/16	11.11	1/2	12.70	13.71	16.00	14.73	21.33
AC-4	1/4	6.35	1/2	12.70	9/16	14.28	15.24	17.78	16.00	23.26
AC-5	5/16	7.93	9/16	14.28	5/8	15.87	16.25	18.54	17.01	24.38
AC-6	3/8	9.52	5/8	15.87	11/16	17.46	16.76	19.30	18.28	25.65
AC-8	1/2	12.70	13/16	20.63	7/8	22.22	22.86	21.84	19.05	29.21
AC-10	5/8	15.87	15/16	23.81	1	25.40	24.38	21.84	19.81	29.97
AC-12	3/4	19.05	1-1/16	26.98	1-1/8	28.57	24.38	21.84	21.33	31.49
AC-14	7/8	22.22	1-3/16	30.16	1-1/4	31.75	25.90	21.84	23.87	34.03
AC-16	1	25.40	1-3/8	34.92	1-1/2	38.10	31.24	26.41	26.16	38.35
AC-20	1-1/4	31.75	1-3/4	44.45	1-7/8	47.63	41.14	38.86	31.24	53.34
AC-24	1-1/2	38.10	2-1/8	53.98	2-1/4	57.15	50.15	45.21	37.33	64.51
AC-32	2	50.80	2-3/4	69.85	3	76.20	67.56	62.73	49.27	86.61

Cap metric tube end

Part No.	Tube O.D. D	Width across flat		A	B	/	L
		h	H				
AC-2M	2	12	12	12.9	15.3	13.5	20.1
AC-3M	3	12	12	12.9	15.3	13.5	20.1
AC-4M	4	12	12	13.7	16.1	14.7	21.3
AC-6M	6	14	14	15.3	17.7	15.7	23.1
AC-8M	8	15	16	16.2	18.6	17.0	24.5
AC-10M	10	18	19	17.2	19.5	19.0	26.6
AC-12M	12	22	22	22.8	22.0	19.0	29.1
AC-15M	15	24	25	24.4	22.0	19.8	29.9
AC-16M	16	24	25	24.4	22.0	19.8	29.9
AC-18M	18	27	30	24.4	22.0	21.3	31.4
AC-20M	20	30	32	26.0	22.0	23.9	34.0
AC-22M	22	30	32	26.0	22.0	23.9	34.0
AC-25M	25	35	38	31.3	26.5	26.2	38.5
AC-28M	28	41	46	36.6	36.6	27.7	48.5
AC-32	32	46	50	42.0	41.6	32.8	55.8
AC-38M	38	55	60	49.4	47.9	37.8	65.4

• For installation, follow the standard M Tube Fitting installation instruction.

**Application :** Tube Cap & Port Plug

In tubing system, it is necessary to install either port plugs or tube caps for test ports or future runs.

- Tube cap for closing off tube end.
- Port plug for closing off an existing fitting port.

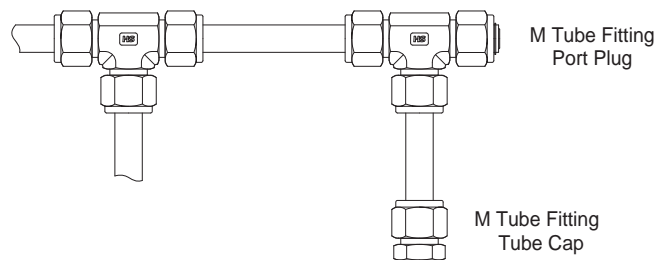

M Tube Fitting Port Plug

M Tube Fitting Tube Cap

Port Plug  
**AP**

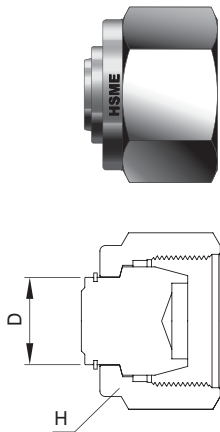

Plugs fractional M Tube fitting® Port

Part No.	Tube O.D. D		Width across flat H	
	in	mm	in	mm
	AP-1	1/16	1.59	5/16
AP-2	1/8	3.17	7/16	11.11
AP-3	3/16	4.76	1/2	12.70
AP-4	1/4	6.35	9/16	14.28
AP-5	5/16	7.93	5/8	15.87
AP-6	3/8	9.52	11/16	17.46
AP-8	1/2	12.70	7/8	22.22
AP-10	5/8	15.87	1	25.40
AP-12	3/4	19.05	1-1/8	28.58
AP-14	7/8	22.22	1-1/4	31.75
AP-16	1	25.40	1-1/2	38.10
AP-20	1-1/4	31.75	1-7/8	47.63
AP-24	1-1/2	38.10	2-1/4	57.15
AP-32	2	50.80	3	76.20

Plugs metric M Tube fitting® Port

Part No.	Tube O.D. D	Width across flat H
AP-2M	2	12
AP-3M	3	12
AP-4M	4	12
AP-6M	6	14
AP-8M	8	16
AP-10M	10	19
AP-12M	12	22
AP-15M	15	25
AP-16M	16	25
AP-18M	18	30
AP-20M	20	32
AP-22M	22	32
AP-25	25	38
AP-28M	28	46
AP-32M	32	50
AP-38M	38	60

Port Plug Installation Instructions

1. Remove the nut and ferrules from the existing M Tube Fitting port.
  2. Finger-tighten the port plug on to the M Tube Fitting port.
  3. Wrench-tighten the port plug 1/4 turn beyond the finger-tight position, keeping the fitting body steady with a backup wrench.
- Do not tighten 1 1/4 turns. Be aware that plug has the machined ferrule not the standard ferrule.
  - Fittings for smaller than 1/4 in. OD (6mm OD), tighten 1/8 turn.

Tube Insert  
**AI**

Fractional Nylon or Soft Plastic Tubing

Part No.	Tube OD		Tube ID		Bore ID
	in	mm	in	mm	
AI 3-2	3/16	4.76	1/8	3.17	2.28
AI 4-2	1/4	6.35	1/8	3.17	2.28
AI 4-3	1/4	6.35	3/16	4.76	3.55
AI 5-2	5/16	7.93	1/8	3.17	2.28
AI 5-3	5/16	7.93	3/16	4.76	3.04
AI 5-4	5/16	7.93	1/4	6.35	4.82
AI 6-3	3/8	9.52	3/16	4.76	3.04
AI 6-4	3/8	9.52	1/4	6.35	4.82
AI 8-4	1/2	12.7	1/4	6.35	4.82
AI 8-6	1/2	12.7	3/8	9.52	7.87
AI 10-6	5/8	15.87	3/8	9.52	7.87
AI 10-8	5/8	15.87	1/2	12.70	11.17
AI 12-8	3/4	19.05	1/2	12.70	11.17
AI 12-10	3/4	19.05	5/8	15.87	14.22
AI 16-12	1	25.4	3/4	19.05	17.52

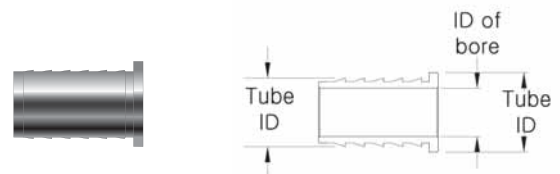

Metric Nylon or Soft Plastic Tubing

Part No.	Tube OD	Tube ID	Bore ID
AI 6M-4M	6	4	2.8
AI 8M-6M	8	6	4.4
AI 10M-8M	10	8	6.4
AI 12M-8M	12	8	6.4
AI 12M-10M	12	10	8.3

Nylon or soft plastic tubing is pliable. They require tube insert to prevent the tubing from collapsing. For installation, follow the standard M Tube Fitting installation instruction.

# M Tube Fittings®

## • Front Ferrule **AFF**

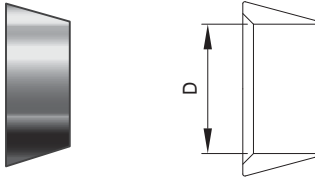

### Fractional

Part No.	Tube O.D.	
	D	
	in	mm
AFF-1	1/16	1.59
AFF-2	1/8	3.17
AFF-3	3/16	4.76
AFF-4	1/4	6.35
AFF-5	5/16	7.93
AFF-6	3/8	9.52
AFF-8	1/2	12.70
AFF-10	5/8	15.87
AFF-12	3/4	19.05
AFF-14	7/8	22.22
AFF-16	1	25.40
AFF-20	1-1/4	31.75
AFF-24	1-1/2	38.10
AFF-32	2	50.80

### Metric

Part No.	Tube O.D. D
AFF-2M	2
AFF-3M	3
AFF-4M	4
AFF-6M	6
AFF-8M	8
AFF-10M	10
AFF-12M	12
AFF-15M	15
AFF-16M	16
AFF-18M	18
AFF-20M	20
AFF-22M	22
AFF-25M	25
AFF-28M	28
AFF-32M	32
AFF-38M	38

### Ordering Information

Stainless Steel over 1 in. and 25 mm OD fittings are supplied with stainless steel ferrules coated with PFA. For application beyond 450°F (232 °C) silver-plated front ferrule are supplied.

To order silver plated front ferrule, insert "SL" to the ordering number. Example: AFF-32-**SL**-SS

## • Back Ferrule **AFB**

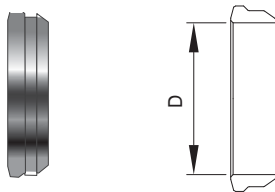

### Fractional

Part No.	Tube O.D.	
	D	
	in	mm
AFB-1	1/16	1.59
AFB-2	1/8	3.17
AFB-3	3/16	4.76
AFB-4	1/4	6.35
AFB-5	5/16	7.93
AFB-6	3/8	9.52
AFB-8	1/2	12.70
AFB-10	5/8	15.87
AFB-12	3/4	19.05
AFB-14	7/8	22.22
AFB-16	1	25.40
AFB-20	1-1/4	31.75
AFB-24	1-1/2	38.10
AFB-32	2	50.80

### Metric

Part No.	Tube O.D. D
AFB-2M	2
AFB-3M	3
AFB-4M	4
AFB-6M	6
AFB-8M	8
AFB-10M	10
AFB-12M	12
AFB-15M	15
AFB-16M	16
AFB-18M	18
AFB-20M	20
AFB-22M	22
AFB-25M	25
AFB-28M	28
AFB-32M	32
AFB-38M	38

### Ordering Information

Stainless Steel over 1 in. and 25 mm OD fittings are supplied with stainless steel ferrules coated with PFA. For application beyond 450 °F (232 °C) uncoated back ferrule are supplied.

To order uncoated back ferrule, insert "UC" to the ordering number. Example: AFB-32-**UC**-SS

• Ferrule Set  
**AFS**

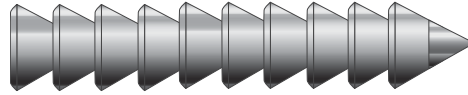

Fractional

Part No.	Tube O.D.	
	in	mm
AFS-1	1/16	1.59
AFS-2	1/8	3.17
AFS-3	3/16	4.76
AFS-4	1/4	6.35
AFS-5	5/16	7.93
AFS-6	3/8	9.52
AFS-8	1/2	12.70
AFS-10	5/8	15.87
AFS-12	3/4	19.05
AFS-14	7/8	22.22
AFS-16	1	25.40
AFS-20	1-1/4	31.75
AFS-24	1-1/2	38.10
AFS-32	2	50.80

Metric

Part No.	Tube O.D.
AFS-2M	2
AFS-3M	3
AFS-4M	4
AFS-6M	6
AFS-8M	8
AFS-10M	10
AFS-12M	12
AFS-15M	15
AFS-16M	16
AFS-18M	18
AFS-20M	20
AFS-2SM	22
AFS-25M	25
AFS-28M	28
AFS-30M	30
AFS-32M	32
AFS-38M	38

• Nut-Ferrule Set  
**AFSN**



Fractional

Part No.	Tube O.D.
	(In.)
AFSN-1	1/16
AFSN-2	1/8
AFSN-3	3/16
AFSN-4	1/4
AFSN-5	5/16
AFSN-6	3/8
AFSN-8	1/2
AFSN-10	5/8
AFSN-12	3/4
AFSN-14	7/8
AFSN-16	1
AFSN-20	1-1/4
AFSN-24	1-1/2
AFSN-32	2

Metric

Part No.	Tube O.D.
AFSN-2M	2
AFSN-3M	3
AFSN-4M	4
AFSN-6M	6
AFSN-8M	8
AFSN-10M	10
AFSN-12M	12
AFSN-15M	15
AFSN-16M	16
AFSN-18M	18
AFSN-20M	20
AFSN-2SM	22
AFSN-25M	25
AFSN-28M	28
AFSN-30M	30
AFSN-32M	32
AFSN-38M	38

## Nut AN

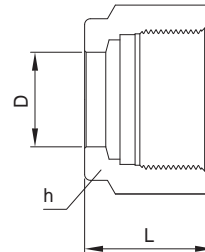

### Fractional

Part No.	Tube O.D.		With across flat		L
	D		h		
	in	mm	in	mm	
AN-1	1/16	1.59	5/16	7.93	7.90
AN-2	1/8	3.17	7/16	11.11	11.93
AN-3	3/16	4.76	1/2	12.70	11.93
AN-4	1/4	6.35	9/16	14.28	12.70
AN-5	5/16	7.93	5/8	15.87	13.46
AN-6	3/8	9.52	11/16	17.46	14.22
AN-8	1/2	12.70	7/8	22.22	17.52
AN-10	5/8	15.87	1	25.40	17.52
AN-12	3/4	19.05	1-1/8	28.57	17.52
AN-14	7/8	22.22	1-1/4	31.75	17.52
AN-16	1	25.40	1-1/2	38.10	20.57
AN-20	1-1/4	31.75	1-7/8	47.63	31.75
AN-24	1-1/2	38.10	2-1/4	57.15	38.10
AN-32	2	50.80	3	76.20	52.32

### Metric

Part No.	Tube O.D.	With across flat	L
	D	h	
AN-2M	2	12	11.90
AN-3M	3	12	11.90
AN-4M	4	12	11.90
AN-6M	6	14	12.70
AN-8M	8	16	13.50
AN-10M	10	19	15.10
AN-12M	12	22	17.40
AN-15M	15	25	17.40
AN-16M	16	25	17.40
AN-18M	18	30	17.40
AN-20M	20	32	17.40
AN-22M	22	32	17.40
AN-25M	25	38	20.60
AN-28M	28	46	30.60
AN-32M	32	50	34.40
AN-38M	38	60	40.60

• Bulkhead  
Jam Nut  
**AJN**

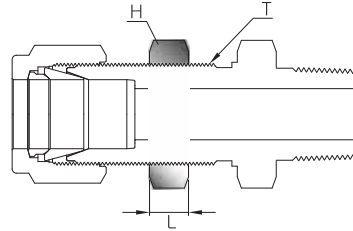

Fractional tube OD

Part No.	Straight Thread T(U)	Width across flat H		L
		in	mm	
AJN-1	10-32	5/16	7.93	3.30
AJN-2	5/16-20	1/2	12.70	4.83
AJN-3	3/8-20	9/16	14.28	5.59
AJN-4	7/16-20	5/8	15.87	5.59
AJN-5	1/2-20	11/16	17.46	5.84
AJN-6	9/16-20	3/4	19.05	6.35
AJN-8	3/4-20	15/16	23.81	7.11
AJN-10	7/8-20	1-1/16	26.98	7.87
AJN-12	1 in. -20	1-3/16	30.16	8.64
AJN-14	1-1/8-20	1-3/8	34.92	9.65
AJN-16	1-5/16-20	1-5/8	41.27	9.65

Metric tube OD

Part No.	Straight Thread T(U)	Width across flat H		L
		in	mm	
AJN-2M	5/16-20	13	4.8	
AJN-3M	5/16-20	13	4.8	
AJN-4M	3/8-20	14	5.6	
AJN-6M	7/16-20	16	5.6	
AJN-8M	1/2-20	17	5.6	
AJN-10M	5/8-20	21	6.4	
AJN-12M	3/4-20	24	7.1	
AJN-14M	7/8-20	27	7.9	
AJN-15M	7/8-20	27	7.9	
AJN-16M	7/8-20	27	7.9	
AJN-18M	1 in. -20	30	8.6	
AJN-20M	1-1/8-20	33	9.7	
AJN-22M	1-1/8-20	33	9.7	
AJN-25M	1-5/16-20	41	9.7	

• Positionable  
Lock Nut  
**APN-UP/GR**

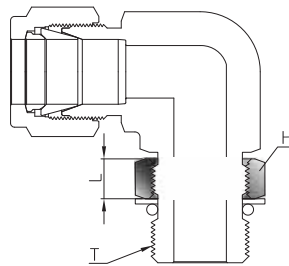

Shown: APN-UP

For SAE Straight Thread

Part No.	Straight Thread T(U)	Width across flat H		L
		in	mm	
APN-2UP	5/16-24	7/16	11.11	5.59
APN-3UP	3/8-24	1/2	12.7	5.59
APN-4UP	7/16-20	9/16	14.28	7.11
APN-5UP	1/2-20	5/8	15.87	7.11
APN-6UP	9/16-18	11/16	17.46	7.11
APN-8UP	3/4-16	7/8	22.22	7.87
APN-10UP	7/8-14	1	25.40	9.14
APN-12UP	1-1/16-12	1-1/4	31.75	10.41
APN-14UP	1-3/16-12	1-3/8	34.92	10.41
APN-16UP	1-5/16-12	1-5/8	38.10	10.41

For ISO Parallel Thread

Part No.	Straight Thread T(PF)	Width across flat H		L
		in	mm	
APN-2GR	1/8	9/16	14.28	7.11
APN-4GR	1/4	3/4	19.05	7.11
APN-6GR	3/8	3/4	19.05	7.11
APN-8GR	1/4	7/8	22.22	7.87
APN-12GR	3/4	1-3/8	34.92	10.41
APN-16GR	1	1-3/8	41.28	10.41

## Gap Inspection Gauge **AIG**



Part No.	Fitting OD	
	in.	mm
AIG-4	1/4, 5/16	6, 8
AIG-6	3/8, 5/8	10, 15, 16
AIG-8	1/2, 3/4	12, 18
AIG-16	1	25

M Tube Fittings are gaugeable.

M Tube Fitting Gap Inspection No-Go gauge ensures sufficient pull-up on initial installation.

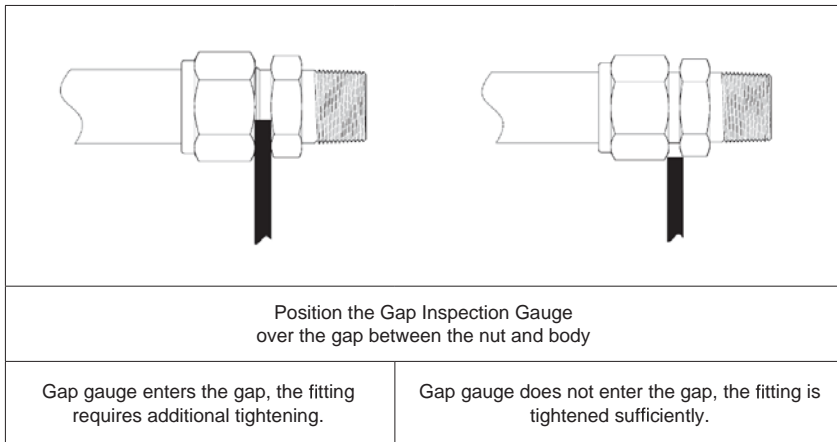

## Tube Depth Marker **ATM**



### Operation Instructions

1. Insert the tubing into the ATM until it bottoms.
2. Mark the tube at top on the ATM.
3. Remove the tube from the ATM and insert it into M Tube Fitting until the marking line becomes flush with the top face of the nut.

#### Fractional

Part No.	Tube O.D. (In.)
ATM-4-C	1/4
ATM-6-C	3/8
ATM-8-C	1/2
ATM-10-C	5/8
ATM-12-C	3/4
ATM-16-C	1

#### Metric

Part No.	Tube O.D. (mm)
ATM-6M-C	6
ATM-8M-C	8
ATM-10M-C	10
ATM-12M-C	12
ATM-16M-C	16
ATM-25M-C	25



• Preswaging Tool  
**APS**



Fractional M Tube fitting®

Part No.	Tube O.D. (In.)
APS-4-C	1/4
APS-5-C	5/16
APS-6-C	3/8
APS-8-C	1/2
APS-12-C	3/4

Metric M Tube fitting®

Part No.	Tube O.D. (mm)
APS-3M-C	3
APS-6M-C	6
APS-8M-C	8
APS-10M-C	10
APS-12M-C	12
APS-16M-C	16
APS-18M-C	18
APS-20M-C	20



**Operation Instructions**

1. Clamp the preswaging tool over the vise firmly.
2. Follow the standard M Tube Fitting installation instruction.
3. Unthread the nut then remove the ferrules-preswaged tubing from the vise.

**Warning:** do not rotate the tubing, but gently rock back and forth if you face difficulty in removing the tubing from the preswaging tool.

4. Reassemble the tubing by following M Tube Fitting reassembly instruction.

**Note:** lubricate the preswaging tool threads on every operation.

• Hydraulic Pre-Swaging Unit  
**AHP**



**For Pre-Swaging Ferrules onto Tubing**

AHP Hydraulic Pre-swaging Unit pre-swages 1/2 to 2 in. and 12 to 50 mm of M Tube Fitting front and back ferrule onto stainless steel and carbon steel tubing.

Supplied in a sturdy plastic case containing swaging head, hydraulic hand pump, hose, and pre-swaging die set.

- Handy and portable for one person operation.
- Carrying case has room for 6 die sets.
- Reduction in makeup torque up to 70% compared to manual pull-up.
- Prevent body thread galling and deformation.
- Consistent swaging onto fitting.
- No initial strain over body seal finish and body thread.

Swaging Dieset Tube OD, in.	Part No.
1/2	A8
5/8	A10
3/4	A12
1	A16
1 1/4	A20
1 1/2	A24
2	A32

Swaging Dieset Tube OD, mm	Part No.
12	A12M
14	A14M
16	A16M
18	A18M
20	A20M
22	A22M
25	A25M
28	A28M
30	A30M
32	A32M
38	A38M
50	A50M

**Ordering Information**

Hydraulic Pre-Swaging Unit  
Ordering Number: **AHP**

To order swaging dieset, select an applicable part number.  
Example: **A8**

## Standard Installation Instruction

M Tube Fittings are supplied with finger-tight position. Therefore fitting disassembly is not necessary prior to installation. For tubing installation, make sure that tubing end is prepared with a square cut, inside and outside burrs are removed.

### M Tube Fittings Up to 1 in. and 25 mm OD

#### Step 1

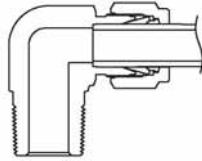

Insert the tubing into the M Tube Fitting until it bottoms the fitting shoulder and finger-tighten the nut.

#### High Pressure and High Safety Applications

Hand-tighten the nut until the tubing does not move axially nor turn by hand in the fitting,

#### Step 2



Mark the nut at 6 o'clock position and wrench-tighten the nut 1 1/4 turns to the 9 o'clock position while holding the body with a second wrench.

For fittings smaller than 1/4 in. and 6 mm OD, tighten the nut 3/4 turn to the 3 o'clock position.

### Fittings Over 1 in. and 25 mm OD



1. Using the hydraulic swaging unit, preswage the ferrules onto the tubing.
2. Insert the ferrules-preswaged tubing into the fitting until the front ferrule seats on the sealing face of the fitting.
3. Finger-tighten the nut and mark the nut at the 6 o'clock position.
4. Wrench-tighten the nut 1 1/2 turns while holding the body firmly.

### Reassembly – All Fittings

M Tube Fittings provide excellent make and remake performance

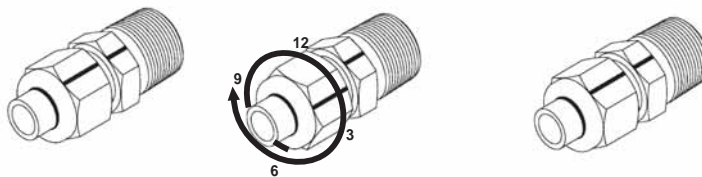

1. Prior to disassembly, mark a line along the nut and body hex; mark the tube flush with the top face of the nut.
2. Insert the ferrules-preswaged tube into the fitting until the front ferrule seats on the sealing face of the body.
3. While holding the fitting body steady, wrench-tighten the nut until the nut line to be in line with the body line. At this point a sharp rise in torque is felt. Only after several remakes will it become necessary to advance the nut slightly past the original position. This advance need only be 10° to 20°, less than 1/3 of a hex flat.

### Inspection on initial Installation

M Tube Fitting Gap Inspection “No-Go gauge” makes sure the make-up distance is sufficiently pulled-up on initial installation.

## Tube Installation

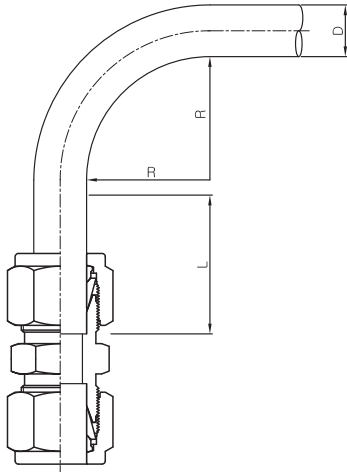

**D: Tube OD**  
**R: Radius**  
**L: Minimum Tube Straight Length**

Maintain the minimum tube straight length all the time as shown in the tables below.  
 If the tubing does not enter the fitting port properly, do not force the tubing but checkup the tubing ovality.

**Warning:** Do not bend the tubing in the fitting. It may damage the sealing system in the fitting.

### Required Minimum Tube Straight Length

Fractional Tube, in.	
D	L
1/16	1/2
1/8	23/32
3/16	3/4
1/4	13/16
5/16	7/8
3/8	15/16
1/2	1 3/16
5/8	1 1/4
3/4	1 1/4
7/8	1 5/16
1	1 1/2
1 1/4	2
1 1/2	2 13/32
2	3 1/4

### Required Minimum Tube Straight Length

Metric Tube, mm	
D	L
3	19
6	21
8	23
10	25
12	31
14	32
15	32
16	32
18	32
20	34
22	34
25	40
28	46
30	50
32	54
38	63
50	80

If the tube bend is too close to the fitting, the bend section shall enter the fitting. This may not allow the tube to be bottomed in the fitting. This may end up with leakage.



The information in this catalog is not for design purpose, but for reference only.  
The accuracy of information is not the liability of our company.

#### Quality System

ISO 9001 : 2008

#### HSE Management System

ISO 14001  
OHSAS 18001: 2007

#### Nuclear Quality System

ASME N  
ASME NPT  
ASME NS  
KEPIC MN

#### Component Selection

The selection of component for any application or system design must be considered to ensure safe performance. Component function, material compatibility, component pressure and temperature rating, proper installation, operation and maintenance remain the sole responsibility of the system designer and the user. HSME Corporation accepts no liability for any improper selection, installation, operation or maintenance.